

INTERNAL BALLISTICS

BROUGHT TO YOU BY
THE DARKWIZARD



PHILOSOPHICAL LIBRARY
NEW YORK

**PUBLISHED, 1951, BY THE PHILOSOPHICAL LIBRARY, INC.,
15 EAST 40TH STREET, NEW YORK, 16, N.Y.**

**All rights reserved
Printed in Great Britain**

PREFACE

In recent years there has been a considerable amount of research in Internal Ballistics, much of which was done as a result of recommendations of the Scientific Advisory Council of the Ministry of Supply. On the recommendation of its Ballistics Committee the Council decided to sponsor the production of a treatise co-ordinating this new work in its application to guns and giving an up-to-date account of the subject.

An editorial panel was formed, the members being :—

Colonel F. R. W. Hunt, M.A., F.Inst.P. (Chairman)

Brigadier G. H. Hinds, O.B.E., B.Sc.

Dr. C. A. Clemmow, M.A., Sc.D.

Professor C. J. Tranter, M.A. (Secretary)

This panel was entrusted with the work of preparing and editing the text and reported progress periodically to the Ballistics Committee. Responsibility for the project was subsequently assumed by the Weapon Research Committee who re-emphasised the importance of the work and initiated steps to expedite its completion.

The treatise is a collective work and the Scientific Advisory Council tender their thanks to the authors for their contributions. They are (in alphabetical order) :—

Mr. C. M. Balfour, M.A., A.M.I.C.E., *Armament Research Establishment*:
Chapter XIII in part.

Dr. C. A. Clemmow, M.A., Sc.D., *Armament Research Establishment*:
Chapters X and XI in part.

Dr. J. Corner, M.A., Ph.D., F.R.I.C., *Armament Research Establishment*:
Chapter III and Appendix I.

Mr. H. A. Flint, B.Sc., A.M.I.Mech.E., *Armament Research Establishment*:
Chapter XIII in part.

Mr. A. W. Goldie, M.A., *University College, Nottingham*
(formerly *Armament Research Establishment*):
Chapter IX in part.

Mr. J. B. Goode, B.A., *Armament Research Establishment*:
Chapter XII and part of Chapter XIII.

Mr. E. P. Hicks, M.A., *Armament Research Establishment*:
Appendix II.

Brigadier G. H. Hinds, O.B.E., B.Sc., *Director of Weapon Research*:
Chapters XIV and XVI and part of Chapter XI.

Colonel F. R. W. Hunt, M.A., F.Inst.P., *Vickers-Armstrongs Ltd.*:
Chapter VIII and parts of Chapters I, V, VII, IX, X, XI and XII.

PREFACE

Major J. C. S. Hymans, M.A., F.F.A., *Consulting Statistician and Actuary*
(formerly Royal Artillery):
Chapter XV.

Dr. H. H. M. Pike, B.Sc., Ph.D., *Armament Research Establishment*:
Chapter V in part.

Mr. C. K. Thornhill, M.A., *Armament Research Establishment*:
Chapter VII in part and Appendix II.

Professor C. J. Tranter, M.A., *Military College of Science*:
Chapters II, IV, VI and part of Chapter XIII.

Lt. Commander J. R. D. Walker, B.A., V.R.D., R.N.V.R., *Vickers-Armstrongs Ltd.*:
Chapter XIII in part.

Professor J. R. H. Whiston, O.B.E., M.A., B.Sc., *Military College of Science*:
Chapter I in part.

In particular the Council wish to express their appreciation of the work done by Colonel Hunt ; not only did he, as Chairman of the Editorial Panel, do the major part of the work of preparing the various contributions for the press, but he himself contributed considerably more than any of the other joint authors. The Council also wish to express their appreciation of the work done by the late Professor C. E. Wright, M.Sc., of the Military College of Science, during the early stages of preparation.

The first five chapters of the book are devoted to the chemical, thermal and ballistic properties of propellants and two ballistic equations are derived relating to the mode and rate of burning. The gun is introduced in Chapters VI and VII and the energy equation and the equation of motion of the shot are deduced.

In Chapter VIII a solution of the ballistic equations for a linear law of burning is given, while Chapter IX is devoted to other solutions of the same problem. Solutions for non-linear law of burning are given in Chapter X. Chapter XI is devoted to a number of approximations which are frequently used.

Chapters XII and XIII deal with the measurement of velocity and pressure and the subject of cordite proof is treated in Chapter XIV. Chapter XV gives an outline of the application of statistical methods to cordite production and proof ; Chapter XVI reviews the results of recent experimental work in America, Germany and this country.

Papers dealing with the theory of leaking guns and the heating of a gun barrel are appended and the book concludes with an extensive bibliography.

Many references are made to A.R.D. Reports, which are not published openly. Such reports can generally be obtained on loan by applying to the Secretary, Ministry of Supply, (T.P.A.3), Technical Information Bureau, Thames House, Millbank, London, S.W.1.

The book is published with the authority of the Chief Scientist, Ministry of Supply.

J. E. LENNARD-JONES,
Chairman,
Scientific Advisory Council,
Ministry of Supply.

EDITOR'S FOREWORD

The compilation of a collective work is always a difficult task ; copy reaches the Editor's hands more or less at random, but it has to be moulded into the general scheme in the order in which it is to appear. This, in turn, may incur much correspondence and discussion before the copy is in the desired form. Our task has been made easier by the whole-hearted co-operation of the principal authors, who have accepted our suggestions, sometimes for an almost complete re-arrangement, and have also graciously submitted to cuts in their copy, in order that the book shall be a unified work. We would like to add our thanks to those of the Chairman of the Scientific Advisory Council for the consideration and help the authors have given us.

While the book was in the press a new edition of Dr. Pike's tables of thermochemical data appeared. We investigated the effect of these new data on the numerical values of the principal propellant constants cited in Chapter II and found that they were not appreciably altered. We therefore decided not to alter the data already printed (which would have delayed publication), but we have added a note wherever necessary calling attention to the transient nature of these data.

Our thanks are due to the Military College of Science, the Armament Research Establishment and particularly to Mr. W. G. Clare of the Directorate of Weapon Research of the Ministry of Supply for the preparation of the drawings and diagrams. We also thank Miss E. B. Dodimead and Mrs. M. C. Martin of Messrs. Vickers-Armstrongs Limited for their very considerable help with the typescript, and Mrs. M. E. Pope of the Armament Research Establishment for her valuable assistance with the bibliography.

Finally, discarding the editorial plural, I wish to express my thanks to my colleagues on the Editorial Panel for their vigilant proof-reading and for their inspiration, encouragement and great assistance throughout the compilation of the book.

F. R. W. HUNT

Chairman, Editorial Panel.

ERRATUM

Page 19, eleventh line; *for* $\left(\frac{\partial T}{\partial p}\right)$ *read* $\left(\frac{\partial p}{\partial T}\right)$.

CONTENTS

| | <i>Page</i> | | <i>Page</i> |
|--|--|-------------------------------|--|
| CHAPTER I | | CHAPTER III— <i>contd.</i> | |
| INTRODUCTION : PROPELLANTS | | 3.03 | Vapour-phase theories 25 |
| 1.01 | Early developments 1 | 3.04 | Theory of a flame in a gas .. 26 |
| 1.02 | Later developments 2 | 3.05 | Propagation of plane reaction zone .. 27 |
| 1.03 | Requirements of modern propellants 3 | 3.06 | Equations for a special case .. 29 |
| 1.04 | Modern developments of propellants 4 | 3.07 | Approximate solution of the equations in the special case 30 |
| 1.05 | Types of propellants now in use. Single base types. Double base types 5 | 3.08 | Variation of the fraction the reaction has progressed and the temperature with distance in the special case 33 |
| 1.06 | German propellants.. .. 6 | 3.09 | Application to the burning of cordite 35 |
| 1.07 | Composition and physical properties of propellants 7 | 3.10 | Comparison with experimental results 37 |
| CHAPTER II | | 3.11 | Subsidiary effects at high pressure .. 37 |
| THE THERMOCHEMISTRY OF PROPELLANT EXPLOSIONS | | 3.12 | Theory of the erosion of cordite .. 38 |
| 2.01 | Introduction 8 | CHAPTER IV | |
| 2.02 | The atomic composition of propellant constituents 8 | THE FORM FUNCTION | |
| 2.03 | Heats of formation of propellant constituents 9 | 4.01 | The law of burning 40 |
| 2.04 | The atomic composition of the propellant 10 | 4.02 | The theoretical form function .. 40 |
| 2.05 | The heat of formation of the solid propellant 10 | 4.03 | Cylindrical 41 |
| 2.06 | The products of explosion .. 10 | 4.04 | Tubular 41 |
| 2.07 | The internal energy of the gases .. 13 | 4.05 | Slotted tube 42 |
| 2.08 | Calculation of the explosion temperature 13 | 4.06 | Ribbon 43 |
| 2.09 | The change of gas composition with temperature 16 | 4.07 | Square flake 44 |
| 2.10 | The pressure of explosion 17 | 4.08 | Multitubular 44 |
| 2.11 | Force constant 17 | 4.09 | Approximations to the form function for multitubular 50 |
| 2.12 | The co-volume and equation of state 18 | 4.10 | Summary 51 |
| 2.13 | The ratio of specific heats 19 | 4.11 | Variation of burning surface as burning proceeds 52 |
| 2.14, 2.15 | Quick approximate method .. 19 | CHAPTER V | |
| CHAPTER III | | COMBUSTION AT CONSTANT VOLUME | |
| THE BURNING OF PROPELLANTS | | 5.01 | Introductory 53 |
| 3.01 | Theories of the burning of gun propellants.. .. 23 | 5.02 | Objects of closed-vessel experiments 53 |
| 3.02 | Surface theories 24 | 5.03 | Experimental determination of the force constant and the co-volume 53 |
| | | 5.04 | Combustion phenomena in a closed vessel 55 |
| | | 5.05 | The theoretical pressure-time curve 57 |

CONTENTS

| | <i>Page</i> | | <i>Page</i> |
|--|-------------|--|-------------|
| CHAPTER V— <i>contd.</i> | | CHAPTER VIII | |
| 5.06, 5.07, 5.08 | 58 | SOLUTION FOR LINEAR RATE OF BURNING <i>The Hunt-Hinds System of Internal Ballistics</i> | |
| 5.09 | 61 | 8.01 | 82 |
| 5.10 | 62 | 8.02 | 82 |
| 5.11 | 64 | 8.03 | 83 |
| 5.12 | 65 | 8.04 | 83 |
| CHAPTER VI | | 8.05 | 83 |
| THE ENERGY EQUATION | | 8.06 | 85 |
| 6.01 | 67 | 8.07 | 86 |
| 6.02 | 67 | 8.08 | 87 |
| 6.03 | 67 | 8.09 | 87 |
| 6.04 | 68 | 8.10 | 88 |
| 6.05 | 68 | 8.11 | 89 |
| 6.06 | 69 | 8.12 | 90 |
| 6.07 | 70 | 8.13 | 92 |
| 6.08 | 70 | 8.14 | 93 |
| 6.09 | 71 | 8.15 | 94 |
| 6.10 | 71 | 8.16 | 95 |
| 6.11 | 71 | 8.17 | 95 |
| 6.12 | 72 | 8.18 | 96 |
| 6.13 | 72 | 8.19 | 97 |
| 6.14 | 72 | 8.20 | 99 |
| CHAPTER VII | | CHAPTER IX | |
| THE EQUATION OF MOTION OF THE PROJECTILE | | OTHER METHODS FOR A LINEAR LAW OF BURNING | |
| 7.01 | 74 | 9.01 | 102 |
| 7.02, 7.03 | 74 | 9.02, 9.03 | 102 |
| 7.04 | 76 | 9.04 | 103 |
| 7.05 | 78 | 9.05 | 106 |
| 7.06 | 79 | 9.06 | 107 |
| 7.07 | 79 | 9.07 | 108 |
| 7.08 | 80 | 9.08, 9.09 | 108 |
| | | 9.10, 9.11 | 111 |
| | | 9.12, 9.13 | 112 |
| | | 9.14 | 115 |

CONTENTS

| | <i>Page</i> | | <i>Page</i> |
|---|--|---|-------------|
| CHAPTER X | | CHAPTER XII—<i>contd.</i> | |
| SOME SOLUTIONS FOR NON-LINEAR LAW OF BURNING | | 12.04 Accuracy of the Boulengé chronograph | 150 |
| 10.01 | Introductory | 12.05 The photo-electric counter-chronometer system | 151 |
| 10.02 | The reduced ballistic equations .. | 12.06 The electric signal | 153 |
| 10.03 | Constant burning-surface with the co-volume coefficient neglected .. | 12.07 The counter chronometer | 154 |
| 10.04 | Constant burning-surface with the simplified energy equation .. | 12.08 The complete P.C.C. unit | 155 |
| 10.05, 10.06 | General form function and energy equation with co-volume coefficient neglected | 12.09 Accuracy of the P.C.C. system .. | 157 |
| 10.07 | General form function with simplified energy equation | 12.10 Muzzle velocity | 159 |
| 10.08 | Concluding remarks on these solutions | CHAPTER XIII | |
| 10.09, 10.10 | Numerical solution for the simplified energy equation with the differential analyser | CLOSED-VESSEL WORK AND THE MEASUREMENT OF PRESSURE IN VESSEL AND GUN | |
| 10.11, 10.12 | Numerical solution of the general equations with the differential analyser | 13.01 Introduction | 160 |
| 10.13 | Special case, form coefficient zero .. | 13.02 The closed vessel | 160 |
| 10.14 | General case, form coefficient not zero | 13.03 Firing a round in the closed vessel .. | 162 |
| 10.15 | After all-burnt | 13.04 Pressure measurement in closed vessel and gun | 162 |
| 10.16 | Step-by-step numerical solution .. | 13.05 The crusher-gauge | 163 |
| CHAPTER XI | | 13.06 The piezo-electric gauge | 164 |
| SOME APPROXIMATIONS | | 13.07 The strain-gauge pressure head .. | 168 |
| 11.01 | Introductory | 13.08 The spring gauge | 168 |
| 11.02 | Effect of charge-temperature variations on muzzle velocity | 13.09 Recording of rate of pressure variation | 172 |
| 11.03, 11.04 | Composite charges | CHAPTER XIV | |
| 11.05 | Monomial formulae for variations .. | THE METHODS OF PROPELLANT PROOF | |
| 11.06 | Interpolation of adjusted charge weights for howitzers | 14.01 Objects of propellant proof | 173 |
| 11.07 | The Le Duc system | 14.02 Difficulty of propellant proof .. | 174 |
| 11.08, 11.09 | Ballistic similitudes | 14.03 Nature of variations | 174 |
| CHAPTER XII | | 14.04 Methods of propellant proof .. | 175 |
| PROJECTILE VELOCITY MEASUREMENT | | 14.05 Absolute ballistics. Master standardisation | 176 |
| 12.01 | Introductory | 14.06 Current standardisation. Comparative ballistics | 177 |
| 12.02, 12.03 | The Boulengé chronograph | 14.07 Propellant proof | 178 |
| | | 14.08 Velocity of adjustment ; adjusted charges ; control charts | 179 |
| | | 14.09 Breaks in ballistics | 180 |
| | | 14.10 Checking of standards | 181 |
| | | 14.11 New nature of propellant | 183 |
| | | 14.12 Special proof procedures | 183 |
| | | 14.13 Miscellaneous definitions | 183 |

CONTENTS

| | <i>Page</i> | | <i>Page</i> |
|---|-------------|---|-------------|
| CHAPTER XV | | CHAPTER XVI | |
| STATISTICAL METHODS AND THEIR APPLICATION TO INTERNAL BALLISTICS | | MODERN EXPERIMENTAL INTERNAL BALLISTICS | |
| 15.01 | 190 | 16.01 | 208 |
| 15.02 | 190 | 16.02 | 208 |
| 15.03 | 191 | 16.03 | 209 |
| 15.04 | 193 | 16.04 | 211 |
| 15.05 | 195 | | |
| 15.06 | 197 | SUMMARY OF NOTATION | 214 |
| 15.07 | 200 | | |
| 15.08 | 200 | NUMERICAL TABLES | 215 |
| 15.09 | 201 | | |
| 15.10 | 201 | APPENDIX I. The theory of leaking guns | 237 |
| 15.11 | 203 | APPENDIX II. The heating of a gun barrel by the propellant gases | 271 |
| 15.12 | 204 | | |
| 15.13 | 204 | BIBLIOGRAPHY | 291 |
| 15.14 | 206 | | |
| 15.15 | 207 | INDEX | 307 |

INTERNAL BALLISTICS

CHAPTER I

INTRODUCTION—PROPELLANTS

Internal Ballistics is the branch of Applied Physics which deals with the ballistic properties of propellants and the motion of the projectile in the gun. The scope of the subject has been extended in the last few years to include the propulsion of rockets ; in this book only the older application to guns is considered.

The history of the subject is so closely associated with the development of propellants, that no better introduction could be given than a brief consideration of this development in its relation to Internal Ballistics.

1.01. Early developments

The history of the subject begins with the use of gunpowder and although the actual date of its first use as a propellant has never been accurately determined, it certainly appears to be early in the fourteenth century. A manuscript compiled about 1320 which was in the Asiatic Museum in Petrograd shows tubes firing both arrows and balls, whilst the illuminated manuscript entitled "De Officiis Regum," written in 1325 and preserved in the library of Christ Church, Oxford, shows a drawing of an elementary gun shaped like a bottle and discharging a dart. Gunpowder was certainly used as a propellant by the English at the Battle of Crecy in 1346.

Improvements in the manufacture of gunpowder followed in succeeding centuries, an important one being in 1784 when the mill-cake was compressed before corning and sieving. This greatly improved the regularity of burning. By the end of the eighteenth century the composition of gunpowder had become fairly-well standardised at 75 per cent. saltpetre, 15 per cent. charcoal and 10 per cent. sulphur.

The first recorded attempt to test powder was made by Bourne in 1578. He fired the powder in a small metal cylinder with a heavy lid on a hinge. The lid lifted on firing and was prevented from falling by a ratchet ; the angle to which it rose gave a measure of the "strength" of the powder.

The earliest recorded attempts to measure the ballistics of the powder consisted of firing at a series of elevations and measuring the range of the shot. These experiments were performed early in the seventeenth century by Collado in Italy and by Master-Gunners Eldred and Nye in England.

In 1742 Robins invented his ballistic pendulum and with it determined the muzzle velocity of musket balls. From these and other experiments he made a number of deductions concerning the pressure exerted by the propellant gases. His researches were recorded in his book "New Principles of Gunnery" (1742) and he was awarded the Copley Gold Medal of the Royal Society for his work in 1747.

Robins' researches were continued by Hutton at Woolwich in the years 1773 to 1791 with a larger pendulum capable of receiving a one-pound ball and his results were generally confirmed.

The first attempt to measure the pressure of propellant gases directly was made by Count Rumford in America in 1792. He fired a gunpowder charge in a vertical éprouvette, the mouth of which was closed by a loaded piston ; the load was adjusted until the piston just lifted. From these experiments Rumford deduced a relation between pressure and density of the gases.

At the end of the eighteenth century ballisticians were able to calculate the relation between pressure and shot-travel, using Rumford's pressure-density relation and assuming that the

charge was completely burnt before the shot started to move. Integrating the pressure-shot-travel curve enabled them to calculate the muzzle velocity and so to compare their results with experimental determinations. No account was taken of cooling, in fact their ideas of the temperature of the gases were extremely vague; Robins, for example, thought that the temperature was at least equal to that of red-hot iron, whereas Hutton estimated it to be at least twice as hot.

The next important development was in 1839, in France, when Piobert enunciated his laws of burning. Although these laws related to black powder, one of them, namely, that the burning of the grain takes place in parallel layers, has been found to be applicable to modern propellants and is still in use. Piobert also gave an approximate solution to the problem of the motion of the gases in the bore, a problem which was originally treated by Lagrange during the time of the French Revolution. He gave an approximate relation between the pressures on the breech and on the base of the shot which is still in use.

In 1857 General Rodman of the American Army devised his "Indentation" pressure gauge for the measurement of the pressure of the propellant gases. The pressure was determined by the indentation made in a copper or lead plate by a piston, in contact with the gases, which was wedge-shaped at its outer end. With this gauge he measured the maximum pressure in a number of guns and also deduced a pressure-density relation in a closed vessel. His observations led him to the problem of reducing the maximum pressure in a gun without reducing the muzzle velocity and he was the first to suggest the proper shape for powder grains. His first proposal was to compress the powder into perforated discs from one to two inches thick and of a diameter to fit the bore. Burning was thus restricted in the early stages and a greater volume of gas was evolved from the increasing surfaces of the perforations in the later stages, when the space behind the projectile was greater. Subsequently he used pierced hexagonal prisms and these "prismatic powders" were speedily adopted in Europe.

The crusher gauge for measuring pressure was invented by Noble in 1860. With this, he and Abel experimented in a closed vessel and deduced the now-famous law of Noble and Abel relating pressure and density at constant volume.

Although Joule made his famous discovery of the mechanical equivalent of heat in 1843, its application to ballistics did not appear until 1864, when Résal published his energy equation. This equation, together with the somewhat later work of Berthelot on heats of formation and reaction placed the subject on a sound thermodynamic basis.

1.02. Later developments

Modern propellants may be considered to date from the attempts of Schönbein from 1845 onwards to use nitrocellulose to replace gunpowder. He obtained the nitrocellulose by the action of a mixture of nitric acid and sulphuric acid on cotton. In these attempts he was unsuccessful, as was von Lenk in Austria, mainly because the extremely rapid burning of the nitrocellulose produced greater pressures than could be withstood by the guns of those days.

None the less it was obvious that nitrocellulose, if it could be "tamed," possessed great potentialities, especially as it burnt leaving no residue, whereas gunpowder produced over half its weight of solid residue. Work therefore continued in several countries and in 1865 Schultze in Germany produced a slower burning material by nitrating wood, the product, after purification, being impregnated with potassium nitrate alone, or mixed with barium nitrate. The wood was certainly incompletely nitrated, and this, coupled with the very different physical properties of the wood in comparison with those of cotton, caused the material to burn much more slowly and gave a product suitable for use in shot-guns, though not in rifled weapons.

In 1882, the Explosives Company at Stowmarket in England commenced manufacture of E.C. powder, which comprised nitrocellulose mixed with potassium and barium nitrates and

other substances. It was made into grains and hardened by partial gelatinisation with an ether-alcohol mixture. Again the product burnt too rapidly for use in rifled guns.

Vieille in France in 1884 was the first to produce a really satisfactory propellant from nitrocellulose. He realised that this could only be achieved by destroying the fine, fibrous structure of nitrocellulose and he found that this could be done by treatment with a mixture of ether and alcohol. It is customary to speak of this process as gelatinisation. Vieille worked the nitrocellulose with an ether-alcohol mixture until a pasty mass was obtained which was rolled into sheets, cut into squares, and freed from residual solvent by drying. The product was adopted by the French Army and named Poudre B, after General Boulanger.

In 1888 Nobel produced a similar result by effecting gelatinisation by means of nitroglycerine. He mixed nitrocellulose with nitroglycerine under water and, by hot-rolling the product, brought about gelatinisation. Like Vieille, he cut the final sheet into squares, and named the product ballistite.

Abel in this country at about the same time used a mixture of nitrocellulose, nitroglycerine and vaseline (mineral jelly), bringing about gelatinisation by means of acetone. Unlike Vieille and Nobel, he did not roll the product, but pressed it out into cords before finally drying off the residual acetone. Owing to its ultimate shape, it became known as cordite, and was adopted by the Services in place of gunpowder in about 1891.

The introduction of these new propellants naturally led to much experimental work to determine their ballistic properties. An important improvement in experimental technique was introduced by Vieille in 1885 ; he obtained the relation between pressure and time during the burning of the propellant in a closed vessel, by registering the crushing of a copper crusher on a rotating drum. From this relation he deduced the rate of burning at pressures comparable to those in guns and enunciated his law of burning, namely, that the rate of burning down the normal to the surface of the grain is proportional to some power of the gaseous pressure. This law and the principle underlying the method of determining it are still used, although the technique has greatly improved.

Another important development during this period was the invention of the chronograph by Boulengé, a Belgian. By means of this instrument, which measured the velocity of the shot a short distance from the muzzle, the muzzle velocity could be deduced with great accuracy. In an improved form it is still in use for routine measurements.

Much theoretical work was published at this time, the chief object of which was the solution of the ballistic equations to determine the motion of the shot in the gun. The solutions varied according to the pressure index in the rate of burning law deduced from closed vessel experiments. Among the earlier solutions may be instanced Sarrau (1876), Moisson (1887), Gossot and Liouville (1905), Ingalls (1903) and Charbonnier (1908). In all these solutions simplifying approximations were made, the commonest being the assumption of zero shot-start pressure and that the co-volume of the gases was equal to the specific volume of the solid propellant.

Charbonnier also introduced a modified form of the rate of burning law which avoided the assumption of burning in parallel layers and in 1913 Sugot published a solution based on this law which was reasonably free from simplifying approximations.

Subsequent work is dealt with in detail in succeeding chapters in this book and this historical sketch is given to indicate briefly the work of the pioneers in internal ballistics. We now consider modern propellants in further detail.

1.03. Requirements of modern propellants

Propellants used in guns are generally in the solid state and function by rapid transformation into gaseous products with the simultaneous evolution of heat, this change of state developing the necessary pressure to produce movement of the projectile. The first requirement of such propellants is, therefore, rapid conversion into gas. Other requirements are :—

- (a) The rate of burning must be regular to ensure ballistic regularity and a steady development of pressure. Burning must therefore be from the surface only and must proceed at a regular rate from layer to layer.
- (b) Smoke and flash must not be produced.
- (c) Erosion of the gun must be as little as possible ; this means that the temperature of combustion must be as low as possible.
- (d) Ignition must be easy.
- (e) Wide variations in temperature of storage should have little effect on the rate of burning and therefore on the ballistics.
- (f) Stability in storage and transport is essential.

The propellants so far considered do not meet all these requirements and we shall see that the most modern types also fail to conform completely with them.

1.04. Modern developments of propellants

We have indicated that whereas Vieille used only nitrocellulose, Nobel and Abel used nitroglycerine in addition. It has since become customary to classify propellants in two groups :—

- (i) Those based essentially on nitrocellulose only, known as *single base* propellants.
- (ii) Those based on nitrocellulose plus nitroglycerine or other similar substances, known as *double base* propellants.

Modern propellants always contain a further ingredient known as a *stabiliser*, the primary function of which is to absorb the decomposition products of nitrocellulose and nitroglycerine formed during prolonged storage and so to prevent their catalysing the decomposition. In addition they may act as cooling agents and gelatinisers. Stabilisers in common use are diphenylamine, mineral jelly and carbamite. Picrite to which we will refer later is also a good stabiliser.

Double base propellants have always been preferred in this country and following the 1914-18 war, research has been concentrated on two main problems :—

- (a) That of producing a propellant which did not use a volatile solvent like acetone in its manufacture. The use of such a volatile solvent is expensive and causes delay in production owing to the time involved in its final removal. Moreover there is always some residual volatile matter which is slowly lost in storage, and this may cause ballistic changes.
- (b) That of producing a cool propellant which would not give flash.

The first problem was solved comparatively quickly by the introduction in 1926 of Cordite SC ("solventless, carbamite") as the standard propellant for the Royal Navy. This propellant was not adopted by the Land Service mainly on grounds of economy, as its manufacture required an entirely different plant ; Cordite MD continued to be used in this Service until 1934 when it was replaced by the ballistically similar, but more stable, Cordite W which was modified in 1939, owing to shortage of carbamite, to Cordite WM.

The second problem of producing a universally flashless propellant has not yet been completely solved. The flash from a gun can be resolved into two (or possibly more) major portions ; the first occurs at the muzzle immediately following the emergence of the projectile ; the second occurs a fraction of a second later, some distance in front of the muzzle and has a far greater intensity of illumination than the first. This latter flash is due to the combustion of hydrogen and carbon monoxide in the propellant gases after admixture with oxygen from the air.

In the 1914-18 war, attempts were made to reduce this major flash by the addition of metallic salts such as sodium oxalate to the propellant. Later work has shown that the salts of potassium, in particular, potassium aluminium fluoride and potassium sulphate are the most

effective. They appear to act by the prevention of one or more of the chain reactions which occur in the oxidation of hydrogen to water. Unfortunately, as they produce in the emergent gases very finely divided particles on which the water-vapour produced in the explosion tends to condense, their use accentuates the production of smoke. An example of this method of reducing flash is found in the addition of potassium cryolite to Cordite HSC.

An alternative method of reducing flash is to incorporate into the propellant a substance which in its decomposition liberates a large amount of nitrogen, so reducing the proportion of the inflammable $\text{CO} + \text{H}_2$ mixture in the muzzle gases. A suitable substance for this purpose is nitroguanidine ("picrite"), though other substances are being tried. In addition, such propellants are much cooler than the older types and thus reduce the tendency to erosion. Examples of these types are Cordites N, NQ and NFQ. It cannot, however, be stated that the problem is completely solved by this method and frequently metallic salts have also to be included with a resulting increase in smoke. This method of reducing flash also involves the use of larger charges, with possible loading troubles; in fact the subject is a complicated one and flashlessness cannot properly be discussed except in relation to a particular weapon.

1.05. Types of propellants now in use

SINGLE BASE TYPES

Single base propellants are standard for American guns and large quantities were imported from that country during the war of 1939-45 for use in the British Service. This type of propellant is exemplified by two main compositions known as NH ("non-hygroscopic") and FNH ("flashless, non-hygroscopic"), both of which contain nitrocellulose and dinitrotoluene, with, in some makes, dibutylphthalate. The stabiliser is diphenylamine. They are supplied in tubular grain form, the small sizes being single tube, the larger sizes multi-tube (seven perforations).

The American Services are showing a tendency to change to the double-base type of propellants, the disadvantages of the single-base type being:—

- (a) They are generally more hygroscopic than the double-base types and are therefore more subject to ballistic change from differences in atmospheric conditions. The use of water-repellent ingredients (dinitrotoluene and dibutylphthalate) gave a considerable improvement in this respect.
- (b) They contain a certain amount of residual solvent which, except in hermetically sealed packages, is slowly lost in storage with a consequent change in ballistics.
- (c) As they are too brittle to use in cord form, B.L. cartridges are objectionably non-rigid. Stiffening of the cartridge bags has been used to meet this difficulty.

It is considered that these disadvantages outweigh their advantages, the chief of which are:—

- (a) They are cooler burning and give less flash than the older double-base type.
- (b) Their granular shape facilitates the filling of Q.F. cartridges.

For small-arms ammunition, Messrs. I.C.I. Ltd. have produced a very satisfactory form of single-base propellant known as Neonite. The required ballistics for different types of ammunition are obtained by surface-treating the propellant grains with methyl centralite and, in some cases, dibutylphthalate. The coating penetrates into the base grain to some extent, so giving in effect a progressively increasing rate of burning as the grain burns away. This coating process is known as "moderation." Similar, but untreated, powders are used as secondary charges for mortars.

DOUBLE BASE TYPES

As has previously been stated, these constitute the standard British propellants. Details of the various types are set out in Table 1.01.

The nomenclature of these propellants is somewhat confused and is at present under review. The initial letters of the name frequently refer to the name of the factory first producing this type, e.g., W for Waltham Abbey, A for Ardeer, but may also refer to specific properties as SC for solventless, carbamite, N for "No flash." The use of the prefix H indicates a hotter variety of the parent propellant as in HSC and HN, whilst M is added to indicate a modified type, as in WM. Code letters are also added to indicate the addition of mineral salts, P being used for potassium sulphate as in N/P. For all propellant shapes except cord, further letters are also added to indicate the shape, these being :—

| | | |
|----|-------------|------------------|
| /T | to indicate | single tubular, |
| /M | „ „ | multi tubular, |
| /S | „ „ | slotted tubular, |
| /R | „ „ | ribbon, |
| /F | „ „ | flake. |

It is convenient to divide these cordites into two main types :—

- (i) Those which normally produce flash and which are made either by the solvent or solventless process.
- (ii) Those which are relatively flashless.

The flashing types of cordite are exemplified by Cordites W, WM and SC, the older types like MD being practically obsolete. Cordite W and WM are produced by the solvent process, in which essentially a dry mixture of nitrocellulose and nitroglycerine is gelatinised by stirring with acetone, the necessary stabiliser being simultaneously added. The product is pressed into the desired shape, and the residual acetone removed by warm air. As has already been noted, the use of a volatile solvent is accompanied by certain drawbacks in the finished cordite.

Cordites SC, HSC and SU are produced without the use of a volatile solvent. Briefly the process consists of mixing the nitrocellulose, nitroglycerine and carbamite under water, removing the water by use of a papering table followed by drying in warm air, and gelatinising by hot rolling. The gelatinised sheets are cut to a suitable size and pressed hot into the desired shape. This process is quick in production and gives a cordite which is extremely uniform in dimensions ; it is also eminently suitable for the production of very large sizes, and also of intricate shapes, e.g., cruciform for rocket charges, which could not be made by the solvent process. Nitrocellulose of high nitrogen content is not so well gelatinised by this process so that low nitrogen content nitrocellulose has to be used, which involves a corresponding adjustment in the composition of the propellant.

Flashless cordites (exemplified by Cordite N) contain a high proportion of nitroguanidine in addition to the usual nitrocellulose, nitroglycerine and carbamite. They appear to require a solvent process for their manufacture, though the amount of acetone required is much less than is necessary for making Cordite W ; the solvent is removed from such propellants more easily, so that the final drying time is much shorter. These cordites are brittle in comparison with the flashing types. On the other hand, before the solvent has been dried out they are very soft and great care has to be taken not to deform the sticks during drying. They are also rather more difficult to ignite than the older types. In one respect this is an advantage since if cartridges containing them are struck and pierced by flying fragments of hot metal, the cordite instead of inflaming, tends only to smoulder and the burning may die out.

1.06. German propellants

The Germans used both single and double-base propellants although in the latter there was an increasing tendency to use diethylene glycol dinitrate (DEGN) in place of nitroglycerine. This was probably due mainly to economic reasons, as the supply of glycerine (normally made by hydrolysis of fats and vegetable oils) was limited, whereas glycol could be made synthetically

from acetylene in unlimited quantity. The main objection to DEGN is its relatively high vapour pressure which might be serious in tropical climates. It is a better gelatinising agent than nitroglycerine, so that successful propellants could be produced using a smaller proportion than would be possible with nitroglycerine, with the added advantage of reducing the calorific value.* To render the propellants less liable to flash, nitroguanidine was also included in the Gu types (flashless types), a common composition being :—

| | |
|----------------|---------------|
| Nitrocellulose | 43 per cent., |
| DEGN | 20 per cent., |
| Nitroguanidine | 30 per cent., |

the balance being made up of stabilisers and plasticisers. Compositions without such additions were sometimes used.

The Germans made considerable use of potassium sulphate or potassium chloride as a means of reducing flash. This material was frequently supplied in bags for use in night firing only, so avoiding the production of smoke by day.

1.07. Composition and physical properties of propellants

The composition and physical properties of some typical propellants are given in Table 1.01. All these propellants are in use in the British Services except MD, which is included for comparison.

The gas volume is determined by burning a small quantity of the propellant in a closed vessel (see Chapter V). The gases are collected and their volume at normal temperature and pressure is measured. The water vapour in the gases condenses under these conditions, so a correction is added to the observed volume to allow for the vapour equivalent of the water thus condensed.

The calorific value is determined by burning a small quantity of the propellant in a bomb calorimeter. This is surrounded by water in a heat-insulated container and the rise in temperature of the water to thermal equilibrium is recorded. From this the heat evolved by combustion is calculated. Since the water vapour in the products of combustion will have condensed at the final temperature, the calorific value so obtained is referred to as water-liquid.

* An explanation of the term "calorific value" is given in Section 1.07.

CHAPTER II

THE THERMOCHEMISTRY OF PROPELLANT EXPLOSIONS

2.01. Introduction

In Chapter I a general account of the composition and properties of propellants was given ; in the present chapter we shall consider some properties which are of special importance in the development of ballistic theory. From a knowledge of the composition of propellants and the thermochemical properties of their constituents and of the products of explosion, it is possible to calculate the temperature at which the gases are evolved and to obtain numerical values of other important quantities.

The first part of this chapter is devoted to the calculation of the first of these quantities, namely, the temperature of explosion, which is sometimes called the adiabatic flame temperature. Departure from the ideal gas laws and the fact that dissociation is not entirely negligible at the high temperatures obtaining complicate the calculation but the essentials of the method are as follows :—

- (i) For a given propellant composition we can compute the number of gram atoms of carbon, hydrogen, nitrogen and oxygen present in one gram of solid propellant.
- (ii) From available thermochemical data, the heat of formation of the solid propellant can be found.
- (iii) The number of gram atoms of C, H, N and O must be the same in the solid propellant as in the gas complex. The major gaseous products are CO_2 , CO , H_2 , N_2 and H_2O ; four of these interact according to the water-gas reaction. At a selected temperature the proportions of the major gases can be computed from the above facts.
- (iv) The internal energy of the gases can now be found, and, if the temperature has been correctly chosen, this energy will equal the heat of reaction, i.e., the difference between the heats of formation of gaseous products and solid propellant.
- (v) The calculation is repeated at different temperatures until the heat balance is obtained.

The method is given in some detail in the following sections.

The other quantities, important in internal ballistics, are deduced in Sections 2.10—2.12 and the later part of the chapter is devoted to a quick approximate method sufficiently accurate for practical purposes.

2.02. The atomic composition of propellant constituents

We shall eventually require the atomic composition of the propellant and it is useful to tabulate once and for all the composition in gm.atoms/gm. of the various chemical substances of which propellants are normally composed. The results are given in Table 2.01, the following atomic weights being used :—

$$\text{C} = 12.010, \quad \text{H} = 1.0080, \quad \text{N} = 14.008, \quad \text{O} = 16.000.$$

As an example, take acetone, of which the chemical formula is $\text{C}_3\text{H}_6\text{O}$ and the molecular weight is 58.078. The atomic composition is therefore given by :—

$$58.078 \{ \text{C} \} = 3, \quad 58.078 \{ \text{H} \} = 6, \quad 58.078 \{ \text{O} \} = 1, \quad \text{or,}$$

$$\{ \text{C} \} = 5165, \quad \{ \text{H} \} = 10331, \quad \{ \text{O} \} = 1722 \times 10^{-5} \text{ gm.atoms/gm.}$$

The nitrocellulose in propellant compositions varies in its nitrogen content and the atomic composition can be obtained as follows. The cellulose molecule is a large one but, for present purposes, it can be written $C_6H_7O_2(OH)_3$. On nitration, x (OH) groups are replaced by (ONO_2) groups, the value of x depending on the nitrogen content. The resulting compound is $C_6H_7O_2(OH)_{3-x}(ONO_2)_x$. The molecular weight is easily found to be $(162 \cdot 14 + 45x)$ and if y is the percentage nitrogen content,

$$y = \frac{1400 \cdot 8x}{162 \cdot 14 + 45x}$$

giving,

$$x = \frac{162 \cdot 14y}{1400 \cdot 8 - 45y} \quad 2,01$$

For a given nitrogen content y , x can be calculated from 2,01 and the atomic composition found from

$$\{C\} = \frac{6}{162 \cdot 14 + 45x} \quad \{H\} = \frac{10 - x}{162 \cdot 14 + 45x} \quad \{N\} = \frac{y}{1400 \cdot 8} \quad \{O\} = \frac{5 + 2x}{162 \cdot 14 + 45x}$$

Table 2.01 shows the atomic composition of all the nitrocelluloses likely to be required.

2.03. Heats of formation of propellant constituents

The heats of formation of the propellant constituents, which are required in the computation of the heat of formation of the solid propellant, can be found by subtracting the heat of combustion of the constituent from the heat of formation of the products of complete combustion, both the latter quantities being known. The heats of combustion have been taken from recent literature by Pike*; the pressure at which they were determined is not always given and no correction has been made to bring the results to conditions of constant volume. Such a correction would reduce the heat of combustion, but in general, its magnitude would be within the limits of experimental error. The data used in compiling the heats of formation of the major products of explosion (Table 2.02) were more accurate and corrections for pressure and temperature have been made. Corrections have also been made to allow for deviations from Boyle's law in going from one atmosphere to conditions of constant volume.

The basic form of carbon has been taken as graphite throughout, since this is the form used for most of the published results. The basic form taken is of no importance since carbon does not appear in the free state in the reactions considered. The heats of formation are all given for a temperature of 300°K. (80·4°F.), this being the standard charge temperature used in internal ballistic work in this country.

Values for the heats of formation of the various propellant ingredients are tabulated in Table 2.01 and, for the purpose of illustration, the value for acetone is worked out below.

From Table 2.02, the heats of formation of CO_2 and H_2O are 94020 and 67400 calories per gram molecule respectively, while Table 2.01 gives for acetone, 5165 and 10331×10^{-5} gm. atoms of carbon and hydrogen. The heat of formation of the products of complete combustion is therefore

$$(94020 \times 0 \cdot 05165) + \frac{1}{2} (67400 \times 0 \cdot 10331) = 8338 \text{ cal./gm.}$$

* Pike, A.C.1862. IB/FP20, IB.78, 1942. Many of the other tables relating to this chapter are from the same report. The sources of the data are given in the original paper. Such data are always subject to revision.

The experimental value for the heat of combustion is (Table 2.01), 7346 cal./gm. and so the heat of formation of acetone is

$$8338 - 7346 = 992 \text{ cal./gm.}$$

2.04. The atomic composition of the propellant

The atomic composition of the propellant can be found immediately when we know its composition. Propellant compositions vary from sample to sample and these variations will be a major source of inaccuracy in the values of the constants deduced. In the absence of more precise data we take nominal compositions as set out in Table 1.01. An example, for Cordite SC, is given below.

Multiplying the amounts of C, H, N and O, extracted from Table 2.01 by the respective amounts of nitroglycerine, nitrocellulose and carbamate in 1 gm. of Cordite SC (Table 1.01) and adding, we have :—

| | C | H | N | O |
|-------------------------|------|------|------|----------------------------------|
| 0.415 gm. N.G. | 548 | 914 | 548 | 1645 |
| 0.495 gm. N.C. (12.2%N) | 1114 | 1425 | 431 | 1790 |
| 0.090 gm. Carbamate .. | 570 | 671 | 67 | 34 |
| 1.0 gm. Cordite SC .. | 2232 | 3010 | 1046 | 3469×10^{-5} gm. atoms. |

The atomic compositions of the various propellants listed in Table 1.01 are given in Table 2.03.

2.05. The heat of formation of the solid propellant

Tables 1.01 and 2.01 also permit the calculation of the heat of formation of the solid propellant. The results are given in Table 2.03 and Cordite SC is again taken as an example; the heat of formation being

$$0.415 \times 349 + 0.495 \times 641 + 0.090 \times 50 = 466.6 \text{ cal./gm.}$$

There is probably a slight error of some two or three calories per gram due to change of the heat of formation of the propellant in going from a mechanical mixture to a colloid, but this quantity is too small to be determined with any certainty.

2.06. The products of explosion

Although propellants contain but four kinds of atoms, namely C, H, N and O, these atoms can combine in different ways to form a very large number of compounds, all of which will be present in greater or lesser amounts in the products of explosion. It is usual to assume that gas reactions take place so rapidly at the high temperatures of propellant explosions that thermodynamic equilibrium is always maintained. This assumption is sufficiently near the truth even for the relatively cool gases resulting from flashless propellants and is, of course, still more exact for the hotter gases of other propellants.

The proportions of the various gases must satisfy the following conditions :—

- (i) the number of gram atoms per gram of C, H, N and O must be the same in the gas complex as in the solid propellant, and

(ii) the ratios of the partial pressures of the various gases are determined by equilibrium constants which vary with temperature and pressure.

If the gases are perfect, the formal relationship for thermodynamic equilibrium between one group and a second into which the first can transform is

$$\frac{\text{Product of partial pressures of second group}}{\text{Product of partial pressures of first group}} = K(T) = e^{-\Delta F/RT}$$

where ΔF is the sum of the free energies of the second group minus the sum of the free energies of the first group, T is the temperature and R the usual gas constant. The decrease in free energy of any gas when the temperature rises from absolute zero can be computed from spectroscopic data and hence the change in ΔF for the complete reaction; $-\Delta F$ at absolute zero is the heat of reaction $-\Delta E$ at that temperature. The heat of reaction at absolute zero is corrected from that at room temperature from a knowledge of the specific heats of the gases over that temperature range. Values of $K(T)$ are given in Table 2.04.

A correction for gas imperfection has been given by Corner.* The equation of state of the gases is taken as

$$p = \frac{nRT}{V} \left\{ 1 + \frac{B}{V} + \frac{nC}{V^2} \right\} \quad 2,02$$

where p is the gas pressure, V the volume per unit mass of gas, n the number of gram molecules in unit mass of gas, R the usual gas constant, T the absolute temperature and B , C are functions of temperature and gas composition. Only the major products CO_2 , CO , H_2 , H_2O and N_2 are used here and B and C are found from the linear sums

$$B = (\text{CO}_2) B_{\text{CO}_2} + (\text{CO}) B_{\text{CO}} + \dots + (\text{N}_2) B_{\text{N}_2} \quad 2,03(a)$$

$$C = (\text{CO}_2) C_{\text{CO}_2} + (\text{CO}) C_{\text{CO}} + \dots + (\text{N}_2) C_{\text{N}_2} \quad 2,03(b)$$

where (CO_2) , (CO) , denote the number of gram molecules of CO_2 , CO , per gram of the gas complex and B_{CO_2} , C_{CO} , are the values of B and C for the pure gases. Numerical values of B , C for the pure gases have been computed by Corner† from the intermolecular forces. The results are shown in Table 2.06.

It can be shown that the equilibrium constant for the water-gas reaction

$$\frac{(\text{CO})(\text{H}_2\text{O})}{(\text{CO}_2)(\text{H}_2)} = K_0 \quad 2,04$$

is given by

$$K_0 = K_0(T) \exp \left\{ -\frac{n \Delta B}{V} - \frac{n^2 \Delta C}{2V^2} \right\} \quad 2,05$$

where

$$\Delta B = B_{\text{CO}} + B_{\text{H}_2\text{O}} - B_{\text{CO}_2} - B_{\text{H}_2}$$

* Corner. A.C.5646/Bal. 147. 1943.

† Corner. A.C.5807/Bal. 158. 1943.

and

$$\Delta C = C_{CO} + C_{H_2O} - C_{CO_2} - C_{H_2}$$

$K_0(T)$ is given in Table 2.04 and ΔB , $\frac{1}{2} \Delta C$, obtained from Table 2.06, are given in Table 2.07. The equilibrium constant is increased by the exponential factor by as much as 50 per cent. at pressures of about 30 tons/sq. in.

The products of explosion at a given temperature and density ($1/V$) can be found by a method of successive approximation. The first stage is to compute the major products CO_2 , CO , H_2 and H_2O , assuming no dissociation. We have then

$$(N_2) = \frac{1}{2} \{N\} \quad 2,06(a)$$

$$(CO) + (CO_2) = \{C\} \quad 2,06(b)$$

$$(H_2) + (H_2O) = \frac{1}{2} \{H\} \quad 2,06(c)$$

$$(CO) + 2(CO_2) + (H_2O) = \{O\} \quad 2,06(d)$$

the quantities in () denoting gram molecules per gram of the various gases while those in { } on the right are gram atoms per gram of propellant and are obtained from Table 2.03. The total number of gram molecules per gram of the gas complex is, from the first three of equations 2,06, $\{C\} + \frac{1}{2} \{H\} + \frac{1}{2} \{N\}$. Four of these products interact according to the water-gas reaction 2,04. If we express (CO) , (H_2) and (H_2O) in terms of (CO_2) and the given quantities $\{C\}$, $\{H\}$ and $\{O\}$ by equations 2,06 and substitute in 2,04 we obtain a quadratic equation for (CO_2) of which only one root will give positive quantities for all the gases.

The dissociation products are given by similar equilibrium constants. Great accuracy is not essential in view of the small amounts of these products and the following equations are given by Corner,

$$(OH) = \frac{(H_2O)}{\sqrt{(H_2)}} \left(\frac{V}{RT} \right)^{\frac{1}{2}} K_1 (T) \exp \left(- \frac{20 n}{V} \right) \quad 2,07(a)$$

$$(H) = \sqrt{(H_2)} \left(\frac{V}{RT} \right)^{\frac{1}{2}} K_5 (T) \quad 2,07(b)$$

$$(NO) = \frac{(H_2O) \sqrt{(N_2)}}{(H_2)} \left(\frac{V}{RT} \right)^{\frac{1}{2}} K_2 (T) \exp \left(- \frac{20 n}{V} \right) \quad 2,07(c)$$

$$(O_2) = \left(\frac{(H_2O)}{(H_2)} \right)^2 \frac{V}{RT} K_3 (T) \quad 2,07(d)$$

$$(O) = \sqrt{(O_2)} \left(\frac{V}{RT} \right)^{\frac{1}{2}} K_4 (T) \quad 2,07(e)$$

$$(N) = \sqrt{(N_2)} \left(\frac{V}{RT} \right)^{\frac{1}{2}} K_6 (T) \quad 2,07(f)$$

where $R = 82.06$, the appropriate value when p is in atmospheres.

The functions K_1, K_2, \dots, K_6 are given in Table 2.04. The minor products are listed in their usual order of importance; only for the hottest propellants is it necessary to include O_2, O and N . Corresponding reductions are made in the quantities of $\{C\}, \{H\}, \{N\}$ and $\{O\}$ available for the major gases. The calculation is then repeated until the computed quantities of the dissociation products agree with the values used at the beginning of the calculation.

The method is illustrated in Section 2.08 where the products for Cordite SC at a given temperature and density are calculated. Calculation shows that at pressures of the order of 25 tons/sq.in., dissociation is negligible for flashless propellants but it may be considerable for hotter propellants. For Cordite SC, it is sufficient to reduce the temperature of the products of explosion by nearly 1 per cent. and, very roughly, the percentage dissociation is inversely proportional to the square root of the pressure and increases by about 50 per cent. for every $100^\circ C.$ rise in temperature.

2.07. The internal energy of the gases

The internal energies of many gases at low pressures have been computed for temperatures up to $5000^\circ K.$ from spectroscopic data. The accuracy is to within 1 per cent. up to $3000^\circ K.$ and within 3 per cent. at $4000^\circ K.$ for the triatomic gases with at least ten times this accuracy for the diatomic gases. The value for a monatomic gas is, of course, $\frac{3}{2} RT$ at constant volume. The data are shown in Table 2.05 for temperatures up to $4000^\circ K.$ in the form of mean molecular heats between $300^\circ K.$ and $T^\circ K.$

Corner (*loc. cit.*) has shown that the internal energy (E) of a gas, which is a function of pressure as well as temperature, can be written

$$E = E_0 + (n/V) E_1 + (n/V)^2 E_2 \quad 2,08$$

where E_0 is the internal energy at constant volume computed in the usual way from the mean molecular heat of Table 2.05, and E_1, E_2 are correcting terms which can be calculated from B and C . Values of E_1 as a function of temperature and mean values of E_2 , which varies very little over our range of temperatures, are given for the various gases in Table 2.08. E_1, E_2 are only included for the major products.

2.08. Calculation of the explosion temperature

A given density is selected, here we have taken $1/V = 0.2$ gm/c.c., and the constitution of the gas complex computed at a given temperature $T^\circ K.$ by the method outlined in Section 2.06. Next, the internal energy is found by multiplying the internal energy of the various gases by their proportions in gram molecules and summing. If the temperature has been correctly chosen, this energy will equal the heat of reaction, i.e., the difference between the heat of formation of the gaseous products (found by multiplying the heats of formation of the various products, Table 2.02, by the proportions present) and the heat of formation of the solid propellant, Table 2.03. If the heat of reaction is greater than the internal energy the selected temperature is too low, a second temperature must be taken and the calculation repeated. Interpolation will then lead to the required temperature which assumes, of course, that there has been no heat loss during the explosion which is taken to occur under conditions of constant volume.

As an example we take the case of Cordite SC at a density of 0.2 gm/c.c. Table 2.03 gives for the atomic composition in 10^{-5} gm.atoms/gm.

$$\{C\} = 2232, \{H\} = 3010, \{N\} = 1046, \{O\} = 3469$$

which, when substituted in equations 2,06 and expressed in terms of (CO_2) , give

$$(\text{CO}) = \cdot 02232 - (\text{CO}_2) \quad 2,09(a)$$

$$(\text{H}_2\text{O}) = \cdot 01237 - (\text{CO}_2) \quad 2,09(b)$$

$$(\text{H}_2) = \cdot 00268 + (\text{CO}_2) \quad 2,09(c)$$

$$\text{and } n = \{C\} + \frac{1}{2} \{H\} + \frac{1}{2} \{N\} = \cdot 04260$$

These equations are derived on the assumption of no dissociation and are subsequently slightly altered : they serve as a means of obtaining a first estimate of the dissociation products.

Taking a tentative temperature of 3100°K, Table 2.04 gives $K_0(T) = 7\cdot 281$, while from Table 2.07 we have $-\Delta B = 31\cdot 6$, $-\frac{1}{2} \Delta C = 255$. Hence, since $1/V = 0\cdot 2$,

$$-(n \Delta B)/V - (n^2 \Delta C)/(2 V^2) = \cdot 2877$$

so that equation 2,05 gives

$$K_0 = 7\cdot 281 \exp(\cdot 2877) = 9\cdot 706$$

Equations 2,09 and the water-gas reaction 2,04 yield

$$\frac{[\cdot 02232 - (\text{CO}_2)] [\cdot 01237 - (\text{CO}_2)]}{(\text{CO}_2) [\cdot 00268 + (\text{CO}_2)]} = 9\cdot 706$$

$$\text{or,} \quad 8\cdot 706(\text{CO}_2)^2 + \cdot 0607(\text{CO}_2) - \cdot 0002761 = 0$$

The positive root of this quadratic is $(\text{CO}_2) = \cdot 00314$ and, assuming no dissociation, the gaseous products at 3100°K. resulting from the combustion of 1 gram of Cordite SC are, from equations 2,09 :—

$$(\text{CO}_2) = 314, \quad (\text{CO}) = 1918, \quad (\text{H}_2\text{O}) = 923, \quad (\text{H}_2) = 582, \quad (\text{N}_2) = 523$$

all in 10^{-5} gm. mol.

A first estimate of the dissociation products can be made from these values for the major products and equations 2,07. Thus, since $(\text{H}_2\text{O}) = \cdot 00923$, $(\text{H}_2) = \cdot 00582$, $1/V = 0\cdot 2$, $n = \cdot 04260$, $T = 3100$ and, (Table 2.04), $K_1(T) = \cdot 1419$, the first of equations 2,07 gives $(\text{OH}) = \cdot 00006$. Similarly the second of 2,07 gives $(\text{H}) = \cdot 00007$ and the remaining equations lead to negligible amounts for the other dissociation products.

These small quantities of (OH) and (H) are formed by robbing the major products. We now recalculate these major products by reducing $\{H\}$ and $\{O\}$ respectively by $\cdot 00013$ and $\cdot 00006$ gm.atoms. We thus have available for the major products in 10^{-5} gm.atoms,

$$\{C\} = 2232, \quad \{H\} = 2997, \quad \{N\} = 1046, \quad \{O\} = 3463$$

and equations 2,09 are replaced by

$$(\text{CO}) = \cdot 02232 - (\text{CO}_2) \quad 2,10(a)$$

$$(\text{H}_2\text{O}) = \cdot 01231 - (\text{CO}_2) \quad 2,10(b)$$

$$(\text{H}_2) = \cdot 00267 + (\text{CO}_2) \quad 2,10(c)$$

n is now equal to $\{C\} + \frac{1}{2}\{H\} + \frac{1}{2}\{N\} +$ the dissociation products, i.e.,

$$n = .04253 + .00013 = .04266$$

Working as before we find $(CO_2) = .00313$ and the other major products are derived immediately from equations 2,10 and $N_2 = \frac{1}{2}\{N\}$. Reworking the dissociation products from the new values of the major products we find them unaltered from the values $(OH) = .00006$, $(H) = .00007$.

The next step is to calculate the internal energies of the various gases at the selected temperature 3100°K. For example, for CO_2 , Table 2.05 gives as the mean molecular heat between 300°K. and 3100°K., 11.664 cal./(gm.mol. °C.), so that

$$E_0 = 11.664 (3100 - 300) = 32659 \text{ cal./gm.mol.}$$

Table 2.08 gives $E_1 = -46500$ cal. (c.c./gm.mol.)/gm.mol., $E_2 = 220 \times 10^4$ cal. (c.c./gm.mol.)²/gm.mol. and since $n = .04266$ gm.mol./gm., $1/V = 0.2$ gm./c.c., equation 2,08 gives the internal energy of CO_2 as

$$32659 - (.04266 \times .2) 46500 + (.04266 \times .2)^2 220 \times 10^4$$

or 32422 cal./gm.mol. Multiplication of these internal energies by the proportions of gases present and summing leads to the internal energy of the gas complex. The work is set out in the second and third columns of the table below.

The fourth column gives the heats of formation of the gaseous products extracted from Table 2.02 and the fifth column is obtained by multiplication by the proportions of the gases. The sum of this column gives the total heat of formation of the products.

| (1) Constituents 10 ⁻⁵ gm. mol./gm. | (2) Internal energy cals./gm. mol. | (3) Internal energy cals./gm. | (4) Heat of formation cals./gm. mol. | (5) Heat of formation cals./gm. |
|---|---|--|---|--|
| (CO ₂) 313 | 32422 | 101.5 | 94020 | 294.3 |
| (CO) 1919 | 17788 | 341.4 | 26700 | 512.4 |
| (H ₂ O) 918 | 25209 | 231.4 | 57510 | 527.9 |
| (H ₂) 580 | 16587 | 96.2 | — | — |
| (N ₂) 523 | 17600 | 92.0 | — | — |
| (OH) 6 | 16780 | 1.0 | -5950 | -.4 |
| (H) 7 | 8344 | .6 | -51530 | -3.6 |
| $n = .04266$ | | Sum=864.1 | | Sum=1330.6 |

The heat of formation of the products is therefore 1330.6 cal./gm., while, from Table 2.03, the heat of formation of the solid cordite is 466.6 cal./gm. The heat of reaction is the difference, viz., 864.1 cal./gm. By a fortunate choice of temperature, this equals the internal energy and so 3100°K. is the temperature of explosion T_0 . It will usually be necessary to carry out the above calculation for two temperatures differing by 100° and then find the temperature which provides the heat balance by interpolation.

2.09. The change of gas composition with temperature

As the temperature of the gas complex decreases from the value giving the heat balance, the composition of the gases changes considerably. Calculations on the lines of Section 2.06 give the following results :—

| Temperature (°K.) | 3100 | 2800 | 2400 | 2000 | 1600 |
|--|------|------|------|------|------|
| Gas composition (10^{-5} gm. mol./gm.) | | | | | |
| (CO ₂) .. | 313 | 324 | 348 | 386 | 455 |
| (CO) .. | 1919 | 1908 | 1884 | 1846 | 1777 |
| (H ₂ O) .. | 918 | 911 | 889 | 851 | 782 |
| (H ₂) .. | 580 | 592 | 616 | 654 | 723 |
| (N ₂) .. | 523 | 523 | 523 | 523 | 523 |
| (OH) .. | 6 | 2 | — | — | — |
| (H) .. | 7 | 3 | 1 | — | — |
| $10^5 n$.. | 4266 | 4263 | 4261 | 4260 | 4260 |

The gas composition at 1600°K. is quite near that obtained from experiments in the bomb calorimeter ; at 1583°K. the calculated composition agrees very closely, as is shown by the following table :—

| Gas | Calculated Composition | | Experimental gm. |
|------------------|-------------------------|------|------------------|
| | 10^{-5} gm. mols./gm. | gm. | |
| CO ₂ | 533 | .234 | .23 |
| CO | 1699 | .476 | .47 |
| H ₂ O | 724 | .130 | .13 |
| H ₂ | 781 | .016 | .02 |
| N ₂ | 523 | .147 | .15 |

It appears therefore that changes in gas composition cease when the temperature drops to 1583°K. and the products are said to "freeze" at this temperature.

It is interesting to compare the calorific value of the calculated composition of the gases at this temperature with that obtained experimentally in the bomb calorimeter.

The heats of formation of the calculated products in cal./gm. are :—

| | | |
|------------------|----|------|
| CO ₂ | .. | 500 |
| CO | .. | 454 |
| H ₂ O | .. | 417 |
| | | 1371 |
| | | 1371 |

Subtracting the heat of formation of the solid propellant, 467 cal./gm., we obtain the theoretical calorific value 904 cal./gm., water gaseous. To adjust this to water-liquid conditions we add the heat evolved in the condensation of .130 gm., which is 70 cal. The calculated calorific value, water liquid, is therefore 974 cal./gm. which agrees reasonably well with the experimental value, 970 cal./gm. in Table 1.01.

2.10. The pressure of explosion

The pressure of (uncooled) explosion for a given gas density can be found from equation 2,02, B and C being calculated from equations 2,03, Table 2.06, and the calculated composition of the gas complex.

Thus for Cordite SC at a density of 0.2 gm./c.c. and temperature of 3100°K.,

$$B = .00313 \times 56.5 + .01919 \times 32.6 + .00918 \times 7.5 + .00580 \times 15.1 + .00523 \times 32.6 \\ = 1.129$$

and similarly, C = 6.054. Hence with $1/V = 0.2$, $n = .04266$, $T = 3100$, and $R = .5384$ (for p in tons/sq.in., V in c.c./gm.),* equation 2,02 gives $p = 17.6$ tons/sq.in.

2.11. Force constant

The quantity $F = nRT_0$ is of fundamental importance in internal ballistics and is termed the "force constant" of the propellant. Corner† has computed temperatures of explosion and the composition of the gas complex for Cordite SC for densities ranging from 0.01 to 0.35 gm./c.c. and shows that the product nT_0 is sensibly constant for quite wide variations in gas density. It is not very material therefore at what density F is calculated and that for $1/V = 0.2$ is usually given.

In practical units we have

$$F = 14.90 nT_0 \text{ inch-tons/lb.} \quad 2,11$$

for use when pressures are measured in tons/sq.in. and densities in lbs./cu.in. In closed vessel work pressures are often measured in tons/sq.in. and densities in gm./c.c., with these units it is customary to denote the force constant by λ_0 and then

* The value of the gas constant has been taken as 82.06 atmos. c.c./mol. deg. C.

† The results given in Sections 2.08, 2.10 are based on the composition of Cordite SC given in Table 1.01. Corner uses a slightly different composition and his results for $1/V=0.2$ differ slightly from those given here.

$$\lambda_0 = 0.5384 n T_0 \text{ (tons/sq.in.) (c.c./gm.)} \quad 2,12$$

For Cordite SC, $n = .04266$, $T_0 = 3100$ so that $F = 1970$ and $\lambda_0 = 71.2$.

2.12. The co-volume and equation of state

The equation of state generally used in internal ballistics is that of Van der Waals, the term due to forces of cohesion being neglected at the high pressures encountered.

The equation takes the form

$$p(V - b) = nRT = TF/T_0 \quad 2,13$$

where b is called the co-volume.

Comparing this with 2,02, we see that b is a function of V and T . In fact,

$$b = V \left[1 - n_0/n (1 + B/V + nC/V^2) \right] \quad 2,14$$

where n_0 is the value of n at the explosion temperature. But for dissociation, n would be constant ; actually it changes very little with temperature and its variation may be neglected.

The following table shows the variation of co-volume with temperature. It gives values of b for Cordite SC at a gas density of 0.2 gm./c.c., the values of B , C and n having been calculated on the lines indicated in Sections 2.08 and 2.10.

| Temperature (°K) | 3100 | 2800 | 2400 | 2000 |
|----------------------|-------|-------|-------|-------|
| Co-volume (c.c./gm.) | 0.956 | 0.955 | 0.953 | 0.948 |

Corner gives the following values for the co-volume at various gas densities at the explosion temperature :—

| Density (gm./c.c.) | 0.1 | 0.2 | 0.3 |
|----------------------|------|------|------|
| Co-volume (c.c./gm.) | 1.02 | 0.96 | 0.88 |

In gun ballistics the gas density seldom exceeds 0.25 gm./c.c. and only reaches this value at the higher temperatures ; at lower temperatures the gas density is much lower. The thermodynamic efficiency of a gun seldom exceeds 0.35, so we need not consider temperatures below about 2000°K., in the case of Cordite SC. In these circumstances we see that b is nearly constant and a representative mean value can be chosen. Similar calculations with other propellants lead to similar results. The mean value usually employed is the value at a gas density of 0.2 gm./c.c. at the temperature of explosion.

In the case of Cordite SC the mean value is 0.956 c.c./gm. or 26.5 c.in./lb.

We conclude that for the temperatures and pressures encountered in internal ballistics the equation of state of the gas complex may, with sufficient accuracy, be written,

$$p(V - b) = TF/T_0 \quad 2,15$$

with b constant.

2.13. The ratio of specific heats

The ratio of the specific heat at constant pressure (σ_p) to that at constant volume (σ_v) for the gas complex at the mean conditions obtaining in the gun is required by the internal ballistics equations.

When the shot emerges from the muzzle, conditions are given approximately by $T = 0.6 T_0$ and $1/V = 0.1$ gm./c.c. If $E(T, V^{-1})$ denotes the internal energy of the gas complex at temperature T and density $1/V$ the specific heat at constant volume at the mean conditions in the gun can be taken as

$$\sigma_v = \{E(T_0, 0.2) - E(0.6 T_0, 0.1)\} / 0.4 T_0 \quad 2,16$$

Then since,

$$\sigma_p - \sigma_v = T \left(\frac{\partial T}{\partial p} \right)_v \left(\frac{\partial V}{\partial T} \right)_p = nR$$

we have

$$\gamma - 1 = nR/\sigma_v \quad 2,17$$

where

$$\gamma = \sigma_p/\sigma_v$$

For Cordite SC we have found in Section 2.08 that $E(T_0, 0.2) = 864.1$ cal./gm. A similar calculation at $T = 0.6T_0 = 1860$, $1/V = 0.1$ gives $E(0.6T_0, 0.1) = 441.4$ cal./gm. Equation 2,16 then gives $\sigma_v = 3409$ cal./gm. $^{\circ}$ C. and, since in heat units, $R = 1.987$ cal./gm.mol. $^{\circ}$ C., equation 2,17 gives $\gamma = 1.248$.

2.14. Quick approximate method

The quantities $F (= nRT_0)$, b and γ are all required in internal ballistic work : all can be found from the composition of the propellant and the tables relating to this chapter by the methods indicated in the preceding sections. The numerical work is, however, rather tedious and a simple semi-empirical method of calculation has been proposed by Hirschfelder and his co-workers* : an indication of this approximate treatment is set out in the succeeding sections.

The calculation of n is obtained by neglecting dissociation so that, as stated in Section 2.06, $n = \{C\} + \frac{1}{2}\{H\} + \frac{1}{2}\{N\}$. Values of $\{C\} + \frac{1}{2}\{H\} + \frac{1}{2}\{N\}$ are tabulated for propellant constituents in Table 2.09 with the notation that n_i is the value of this quantity for the i^{th} constituent. If then x_i is the weight fraction of the i^{th} constituent

$$n = \sum_i x_i n_i \quad 2,18$$

the summation \sum_i being over all the constituents of the propellant. The error in using equation 2,18 will be very small for, as we have already seen, dissociation has little effect on the value of n .

The specific heat of the gas complex is found from

$$\sigma_v = (CO_2) (C_v)_{CO_2} + (CO) (C_v)_{CO} + \dots + (N_2) (C_v)_{N_2} \quad 2,19$$

where $(C_v)_{CO_2}$, etc. are the molecular heats at constant volume for the several gases meaned between 2000° K. and 3000° K. The values used for these mean molecular heats are :—
 $(C_v)_{CO_2} = 12.824$, $(C_v)_{CO} = 6.813$, $(C_v)_{H_2O} = 10.905$, $(C_v)_{H_2} = 6.530$ and $(C_v)_{N_2} = 6.767$ cal./gm.mol. $^{\circ}$ C. Much of the labour of the previous work has been taken by computing

* Hirschfelder and Sherman. N.D.R.C. Report No. A-101, O.S.R.D. Report 935, 1942 and N.D.R.C. Armor and Ordnance Memos. Nos. A-67M to A-70M, O.S.R.D. Report 1300, 1943.

(CO₂), (CO), etc. from the water-gas reaction. Such a process clearly cannot find a place in a quick approximate method. Instead σ_v is calculated first on the assumption that there is no CO₂ and secondly on the assumption that there is no H₂O. The two values are then meaned. If there is no CO₂, equations 2,06 give

$$\begin{aligned}(\text{CO}_2) &= 0, & (\text{CO}) &= \{C\}, & (\text{H}_2\text{O}) &= \{O\} - \{C\}, \\ (\text{H}_2) &= \frac{1}{2} \{H\} + \{C\} - \{O\}, & (\text{N}_2) &= \frac{1}{2} \{N\}\end{aligned}$$

and if there is no H₂O we have

$$\begin{aligned}(\text{CO}_2) &= \{O\} - \{C\}, & (\text{CO}) &= 2 \{C\} - \{O\}, & (\text{H}_2\text{O}) &= 0, \\ \text{H}_2 &= \frac{1}{2} \{H\}, & (\text{N}_2) &= \frac{1}{2} \{N\}\end{aligned}$$

Mean values are therefore

$$\begin{aligned}(\text{CO}_2) &= \frac{1}{2} \{O\} - \frac{1}{2} \{C\}, & (\text{CO}) &= \frac{3}{2} \{C\} - \frac{1}{2} \{O\}, & (\text{H}_2\text{O}) &= \frac{1}{2} \{O\} - \frac{1}{2} \{C\} \\ (\text{H}_2) &= \frac{1}{2} \{H\} + \frac{1}{2} \{C\} - \frac{1}{2} \{O\}, & (\text{N}_2) &= \frac{1}{2} \{N\}\end{aligned}$$

Inserting these expressions and the numerical values of $(C_v)_{\text{CO}_2}$, etc. in equation 2,19 we find

$$\sigma_v = 1.620 \{C\} + 3.265 \{H\} + 3.384 \{N\} + 5.193 \{O\}$$

Values of this quantity are tabulated for propellant constituents in Table 2.09 with the notation $(C_v)_i$ for the i^{th} constituent and σ_v is then found from

$$\sigma_v = \sum_i x_i (C_v)_i \tag{2,20}$$

Hirschfelder also tabulates the energy released at 2500°K. This is the difference between the heat of reaction and the internal energy at this temperature. The actual composition of the gas complex is not calculated but the energy released is found as a weighted mean between the two extremes of no CO₂ and no H₂O. The weighting is such that there are 77 gram molecules of H₂O in the gas complex for every 23 gram molecules of CO₂, these numbers being obtained from an examination of an experimental propellant used by Crow and Grimshaw.*

The energy released at 2500°K. is denoted by $(E_{\text{rel.}})_{2500^\circ\text{K}}$ and is given by

$$(E_{\text{rel.}})_{2500^\circ\text{K}} = \sum_i x_i E_i \tag{2,21}$$

the tabulated quantity being E_i for the i^{th} constituent of the propellant. Details of the formula from which E_i was computed are given in the original report quoted; lack of space forbids a reproduction here.

At any temperature T , the energy released is given by

$$E_{\text{rel.}} = (E_{\text{rel.}})_{2500^\circ\text{K}} - (T - 2500) \sigma_v$$

* Crow and Grimshaw, Phil. Trans. Roy. Soc. A-230, 1931.

In particular, at the explosion temperature T_0 , $E_{rel.}$ is zero and we have

$$T = 2500 + (E_{rel.}) 2500^\circ\text{K}/\sigma_v$$

which, with equations 2,20, 2,21 gives

$$T_0 = 2500 + (\sum_i x_i E_i)/(\sum_i x_i (C_v)_i) \tag{2,22}$$

and this formula and Table 2.09 permit the explosion temperature to be calculated very quickly.

At temperatures above 3000°K . dissociation becomes important. An examination of one of Crow and Grimshaw's hot propellants led Hirschfelder to the formula

$$y = E_{rel.} - E'_{rel.} = -0.1185 (T - 3000) - 8.27 \times 10^{-5} (T - 3000)^2 \tag{2,23}$$

where $E'_{rel.}$ is the energy released if dissociation did not occur.

Thus we have

$$E_{rel.} = (E_{rel.}) 2500^\circ\text{K} - (T - 2500) \sigma_v + y \tag{2,24}$$

Putting $E_{rel.} = 0$, $T = T_0$, using 2,24 ; 2,23 ; 2,21 ; 2,20 and solving the quadratic in T_0 , gives for explosion temperatures above 3000°K .

$$T_0 = 3000 + 6046 \left\{ -(\sum_i x_i (C_v)_i + 0.1185) + \left[(\sum_i x_i (C_v)_i + 0.1185)^2 + 3.308 \times 10^{-4} \sum_i (x_i E_i - 500x_i (C_v)_i) \right]^{\frac{1}{2}} \right\} \tag{2,25}$$

Once σ_v has been found from equation 2,20 and n from equation 2,18, the value of γ is immediately given by equation 2,17, viz.,

$$\gamma - 1 = nR/\sigma_v$$

The calculation for Cordite SC is :—

| Constituent | x_i Table 1.01 | n_i Table 2.09 | $x_i n_i$ | $(C_v)_i$ Table 2.09 | $x_i (C_v)_i$ | E_i Table 2.09 | $x_i E_i$ |
|------------------------------|---------------------|---------------------|-----------|-------------------------|---------------|---------------------|-----------|
| Nitrocellulose (12.2% N.) | .495 | .04127 | .02043 | .3478 | .1722 | 137.7 | 68.2 |
| Nitroglycerine | .415 | .03083 | .01279 | .3439 | .1427 | 951.9 | 395.0 |
| Carbamite | .090 | .10443 | .00940 | .3909 | .0352 | -2765.8 | -248.9 |
| Sum = 1.000 | | Sum = .04262 | | Sum = .3501 | | Sum = 214.3 | |

$$\sum_i x_i (C_v)_i + 0.1185 = .3619, \quad \sum_i (x_i E_i - 500x_i (C_v)_i) = 39.3$$

Substitution in equation 2,25 gives $T_0 = 3106$. Also from equation 2,17

$$\gamma - 1 = .04262 \times 1.987/.3501 = .242$$

Hence the approximate method gives, for Cordite SC, $n = .04262$, $T_0 = 3106$, $F = 1970$, $\gamma = 1.242$ while the more laborious methods of Sections 2.08, 2.13 give $n = .04266$, $T_0 = 3100$, $F = 1970$, $\gamma = 1.248$.

For the co-volume, Corner gives the following empirical formula

$$b \text{ (c.c./gm.)} = 1.18 + 6.9 \{C\} - 11.5 \{O\} \quad 2,26$$

the expressions in $\{ \}$ being the number of gram atoms of C and O in 1 gram of propellant. These quantities are given in Table 2.03 and equation 2,26 gives a quick means of finding co-volumes at pressures in the neighbourhood of 20 tons/sq. in. For Cordite SC, $\{C\} = .02232$, $\{O\} = .03469$, so that $b = 0.94$ c.c./gm. The value calculated in Section 2.12 was 0.96.

A comparison of values for the fundamental ballistic quantities calculated by the methods of this section with those given by the more elaborate methods is given below. The latter values are, for the most part, taken from Corner's paper.

| Propellant | n (10^{-5} gm.atoms/gm.) | | T_0 °K. | | Co-volume at 0.2 gm/c.c. | |
|------------|-------------------------------|---------------|---------------|---------------|--------------------------|---------------|
| | By Sect. 2.14 | By Sect. 2.08 | By Sect. 2.14 | By Sect. 2.08 | By Sect. 2.14 | By Sect. 2.12 |
| NH | 4372 | 4374 | 2695 | 2680 | 0.96 | 0.99 |
| WM | 4170 | 4188 | 3214 | 3223 | 0.92 | 0.94 |
| W | 4076 | 4085 | 3304 | 3299 | 0.92 | 0.93 |
| HSC | 3858 | 3887 | 3600 | 3621 | 0.89 | 0.91 |

2.15. Table 2.10 sets out values for adiabatic flame temperature, force constant, covolume and γ for the propellants of Table 1.01. These have been calculated by the approximate methods of the last paragraph and, except for the potassium nitrate of Cordite AN, the small amounts of inorganic salts in the compositions have been neglected owing to lack of the relevant data.

The moisture and solvent contents have also been omitted. For solventless and picrite propellants these are quite small. For Cordite WM the acetone content may be nearly one per cent. for the largest sizes, the moisture content being about one-half of this. For American propellants, the moisture content may be of the order of 0.5 per cent. but the residual (ether-alcohol) solvent content increases with the size up to some 3.5 per cent. for the largest size. A moisture content of one per cent. reduces the force constant by about one per cent. and solvent content of one per cent. reduces it by nearly 2 per cent., depending on the particular propellant.

CHAPTER III

THE BURNING OF PROPELLANTS

3.01. Theories of the burning of gun propellants

There are very few such theories, and they can be summarised quickly. Before doing this, it is worth considering whether there is any need for a theory. One result of a fully developed theory will be a formula showing how the rate of burning depends on composition, initial temperature, and pressure. There will be perhaps one or two constants to be determined by fitting to a few observed rates of burning. The possibility of predicting rates of burning is not, however, a justification for a theory of burning; the rate of a propellant can be guessed from its composition sufficiently closely for the purpose of predicting compositions with required characteristics.* This assumes a knowledge of the rates of a number of propellants of similar physical nature: colloidal propellants with an emulsion as stabiliser (for example, mineral jelly) are noticeably faster than colloidal propellants of the same explosion temperature but with stabiliser distributed homogeneously (for example, carbamite); likewise, picrite propellants contain this substance as crystals enmeshed in the gel, so it is perhaps not surprising that the rate depends on the size of the crystals. Many data have been accumulated about all such types of colloidal propellant, so that it is not necessary to appeal to theory for the dependence of rate on composition. The variations with pressure and initial temperature are also obtainable from closed-vessel experiments. In short, the rate of burning can serve as a check on a theory or a way of evaluating its constants, but cannot be a reason for setting up the theory.

The real value of a theory of burning lies in its physical and chemical picture of the process. If this picture is reasonably close to the truth it helps us to understand various phenomena associated with burning, for example, "erosion," and ignition. A successful theory would provide a general understanding of these phenomena, and would indicate the possibilities of control; it might also extend to quantitative predictions, but that is perhaps too much to expect. Even a qualitative theory can be a valuable guide in the choice of significant experiments. Therefore a theory of the burning of a propellant may give small discrepancies from experiment, showing that it is quantitatively deficient, and yet it may provide an understanding of the process sufficient for many needs.

All theories put forward up to now can be divided into two types: the first may be called the "surface theories," in which the burning is controlled by the rate at which energy (in the right form) is transmitted from the hot products to the surface of the solid propellant; the second class of theories fix attention on the reactions in the gas phase, which are thought to control the overall rate. The latter may be called "vapour-phase theories." These names indicate the feature which is thought to be the *controlling* phenomenon.

* One way is to plot the rates of burning (at a given pressure) against uncooled temperatures of explosion or calorimetric values. The points lie near a smooth curve. These properties can be calculated from the composition. Hence the rate of burning can be estimated from composition.

Muraour (Comp. Rend. 187 (1928) 289) found that log (rate of burning) was a linear function of the uncooled explosion temperature for a series of colloidal propellants (NC-NG-carbamite). This form of relation gives quite a good fit to British data for propellants of this type, though the fit is not so close as Muraour found.

3.02. Surface theories

These have been suggested by Létang, Schweikert, Muraour, Yamaga, and Crow and Grimshaw ; Muraour's work has also been reviewed by Schmidt.*

These theories consider the rate at which energy is transferred from the hot gas to the solid. The molecule of the propellant may be supposed to react if it receives a sufficiently large amount of energy, by being struck by a fast-moving gas molecule. This is the essential part of the theories of Muraour, Yamaga, and Létang. An important point is therefore the energy-distribution of the molecules which strike the surface. What energy-distribution is to be assumed for the molecules (that is, the "average temperature of their origin") is a point at which the theories differ.

These theories give a rate of burning proportional to the number of sufficiently energetic collisions per unit area per second, and if the energy-distribution of the impinging molecules does not depend on the pressure, the rate of burning is proportional to pressure. Muraour has discussed the energy-distribution in a qualitative way, and has arrived at the relation

$$M = a + bp$$

where p is the pressure, M is the rate of burning (mass per unit area per second), and a and b are constants.

At high pressures the number of impacts per unit area per unit time is not exactly proportional to pressure, being altered by the finite size of the molecules.

Muraour has discussed qualitatively the dependence of the rate on the uncooled explosion temperature. Although his theory has not been given a quantitative development, it has obviously been of value in guiding experiment. His picture involves a decomposition of the solid which may be only incomplete and followed by reactions in the gas phase, ending in the usual equilibrium products. This is much the same as the process assumed by Boys and Corner (Section 3.03), but the controlling rate is very different in the two theories. For Muraour the rate of the whole process is fixed by the rate at which decomposition occurs at the surface of the solid propellant.

Yamaga has produced a more quantitative theory based on less acceptable physical ideas ; for instance, he identifies the temperature of the impinging molecules with the uncooled explosion temperature, and he assumes that a surface molecule has to be in an activated state before it can react. Létang had earlier produced a similar theory without activation of the surface molecules by the thermal energy of the solid. For a critique of these theories see Corner.†

Crow and Grimshaw assumed that a molecule of the propellant requires extra internal vibrational energy before it will decompose. This energy was supposed to be supplied by the internal vibrational energy of the impinging gas molecules coming from the layer outside the solid. The temperature of the gas molecules was taken to be the uncooled temperature of explosion. The vibrational energy obtained by the propellant appears as an increase of temperature, and the amount necessary for decomposition is measured by the ignition temperature or "touch-off" temperature. The rate of transfer of vibrational energy from impinging molecule to solid is governed by an accommodation coefficient. The two arbitrary parameters

* Létang, *Mem. Artill. Franc.* 1 (1922) 955.

Schweikert, *Innere Ballistik*, (1923).

Muraour, *Bull. Soc. Chim.* 41 (1927) 1451 ; 47 (1930) 261 ; *Comp. Rend.* 192 (1931) 227.

Muraour and Schumacher, *Mem. Poudres* 27 (1937) 87.

Yamaga, *Zeit. ges. Schiess-und-Sprengstoffwesen* 25 (1930) 60.

Crow and Grimshaw, *Phil. Trans. Roy. Soc. A.* 230 (1931) 387.

Schmidt, *Zeit. ges. Schiess-und-Sprengstoffwesen* 27 (1932) 1, 45, 82.

† Corner, A.R.D. Theoretical Research Report 2/43.

for each propellant were chosen to reproduce the rate of burning and its dependence on the initial temperature of the propellant. The touch-off temperature varied considerably over the four types of cordite studied, and its prediction from composition would appear to be difficult.

Crow and Grimshaw concluded that the rate of burning at high pressures was proportional to the density of the gas rather than its pressure. This has been challenged from the experimental side,* and its deduction from the assumptions of their theory might also be questioned.

All these theories lead to the conclusion that the rate of burning depends on the gas temperature near the solid. From experiment† it is known that the rate is not affected by proximity to a different propellant. This shows that the effective gas-layer round any piece of cordite contains only gas emitted from this propellant; mixture of the products of the various propellants takes place further from their surfaces. For the same reason the temperature of uncooled explosion in these theories should be the temperature at constant pressure, not that at constant volume, as so often used. The difference between these temperatures is of order 500°C.

3.03. Vapour-phase theories

A possible criticism of all the previous theories is that they pay insufficient attention to the reactions in the layer of gas just outside the solid. The bombarding molecules come from a layer which is at most a few mean paths thick. Their effective temperature is supposed to be the temperature of explosion, or very near it. The reactions of the gas leaving the surface are therefore assumed to evolve no heat outside this layer. Moreover, no appreciable reaction can occur in the few collisions suffered in traversing this layer. This means that these theories assume the surface decomposition of the propellant to give the final products in one stage; or if not the final products then gases which transform into the final products without evolution of heat.

Such a conception is hardly in accord with modern views on chemical reactions. These lead us to expect a primary decomposition of the solid into gases which probably undergo many reactions before the final products are reached. Homogeneous gas reactions must be going on in the gas for a distance of some hundreds of free paths from the solid. Boys and Corner have therefore proposed a theory which considers the gradual progress of reaction in this zone. The reactions were idealised to a single reaction leading from the "intermediate products" of the primary decomposition of the solid, up to the final equilibrium products. It was assumed that most of the heat of explosion was given out in this gas reaction. This sweeping idealisation of the actual reactions was made necessary by the difficulty of handling any more complicated case, and also by the lack of information (at that time) of the probable intermediate products. A theory of flames in gases was used to find the mass-consumption of the reaction zone, and so the rate of burning of the solid. The order of the chemical reaction decides how the rate of burning (M) depends on the pressure p ; for example, a first-order reaction leads to M varying as \sqrt{p} and a second-order reaction to M varying as p .

These results suffice to represent the observed variation of the rate of burning with pressure. Let it be assumed that there are parallel routes from "intermediate" to final products, whose overall rates are first and second order; then at sufficiently low pressures the first-order set of reactions will predominate and M will vary as \sqrt{p} ; at high pressures the second-order reaction will be the more important, and M will vary as p in this pressure region. This does indeed represent the general behaviour of propellants. At high pressures there enter other effects.

* Hunt and Hinds, Proc. Roy. Soc. A. 138 (1932), 696.

† Muraour, Z. phys. Chem. A. 139 (1928), 163.

It may be mentioned here that calculation has shown that the ratio M/p at 20 tons/sq. in. can fall to about 80 per cent. of its value at low pressures (say 5 tons/sq. in.). The points to be noted are : (i) the change being the resultant of several effects of different signs, there is no reason to expect all propellants to show closely similar high-pressure behaviour ; (ii) the results can be expressed in terms of either the pressure or density, but not necessarily as a simple form in either case.

The earliest form of their theory was not entirely satisfactory quantitatively. The steep concentration-gradient in the reaction-zone causes a significant diffusion of products and reactants. Not until diffusion had been included in the theory was it possible to get agreement with experiment with reasonable assumptions about molecular weights, heats of reaction and collision numbers. The theory of the flame-zone, allowing for diffusion, has been published by Corner.* In this book we shall present only the simpler theory omitting diffusion, since the latter effect does not alter the physical picture nor does it affect the form of the dependence on pressure, while the equations are simpler without diffusion terms.

The theory of Boys and Corner has a close connection with the work of Belajev,† though it was developed in ignorance of the latter. Belajev's theory refers to the burning of volatile explosives, which he sharply distinguishes from propellants. His idea is that the surface of the explosive is emitting it as vapour, and that its decomposition takes place in the gas phase just outside the liquid surface. The surface temperature is the boiling-point of the liquid at the given pressure. This is clearly not applicable to cordites, and is replaced in Boys' theory by the assumption that the substances being emitted from the surface into the gas reaction-zone are products of the low-temperature decomposition of the propellant. Apart from these differences the theories are much the same. Belajev used the theoretical work of Zeldowitch and Frank-Kamenetsky on flames in gases, which is in many ways similar to the work of Boys and Corner.‡

The essential feature of both these "vapour-phase" theories is that the rate of burning is fixed by the mass-consumption of the flame outside the surface. The consumption of the flame is decided by its characteristics alone.

We shall now give the simplest form of the theory of a flame zone, then the application to the "vapour-phase" theory of the burning of a homogeneous propellant ; finally we shall mention the effects which enter at very high pressures.

Before passing on to these matters, it must be said that the theory which follows is applicable only at gun pressures. The phenomena at rocket pressures, of order a few hundred lb./sq. in., are more complicated. This field has been much studied in America, particularly by B. L. Crawford and O. K. Rice, and it appears to be necessary to consider several successive reactions to explain the observations. Reactions inside the solid are important, and it is no longer possible to speak of a purely "vapour-phase" theory. The difference between the two fields can be illustrated thus : the rate of burning of a rocket propellant has been found to depend on the mean molecular weight of the nitrocellulose, which is a long-chain polymer with a wide range of possible chain-lengths ; on the other hand, the mean molecular weight of the nitrocellulose has never been proved to affect the rate of burning at gun pressures.

3.04. Theory of a flame in a gas

A reaction zone moves through a medium by the transfer of some activating influence from the portion already reacted to an unreacted part. This in its turn reacts and again activates more unreacted material. In an exothermic reaction there are several ways in which

* Corner, Proc. Roy. Soc. A. 198 (1949) 388 ; also A.R.D. Theoretical Research Report 1/43.

† Belajev, Acta Physicochimica 8 (1938) 763 ; 14 (1941) 523. Comp. Rend. U.R.S.S. 24 (1939) 254.

‡ For the relation between the two theories, and a review of all flame theories up to 1942, cf. Corner, A.R.D. Theoretical Research Report 1/43.

the activating influence may be transferred. These are the flow of heat, diffusion of active particles or catalytic intermediate products, or radiation. In all cases of the burning of cordite there are products at extremely high temperature, and there is a considerable flow of heat from these to the unreacted portion. We shall ignore the other possibilities of activation and merely consider the flow of heat, a picture which can conveniently be described as the simple thermal model. We shall examine the rate at which the activating heat is transferred, by calculating the thermal conduction from the distribution of temperature through the zone.

We shall examine the steady propagation of a plane reaction zone through a homogeneous medium with the following properties :—

- (i) the medium is capable of a single exothermic reaction whose rate at any point in the medium is determined solely by the temperature, pressure, and the stage to which the reaction has proceeded at the point ;
- (ii) the velocity of the reaction zone is so slow that the pressure is effectively constant through this zone.

Diffusion will be neglected.

The general analysis would apply to a flame in a gas, or to the movement of a reaction zone in a solid or liquid, provided the above conditions were fulfilled. We shall examine the general case, and then a special case in which constant specific heats and thermal conductivities, together with activation energy formulae for the reaction rate, are assumed. The general case can always be integrated numerically when the necessary data are available, and in the special case an explicit formula for the rate of burning can be obtained.

We shall examine the structure of a plane reaction zone which is in steady motion. We wish to predict the speed for which such a steady motion is possible. We shall exclude the phenomenon of detonation, whose speed is very different from that of any flame. A complete theory would cover detonation and such non-steady phenomena as ignition and the transition to detonation. Throughout this work we shall consider only the steady motion of flames.

This restriction leaves two points uncertain : in the first place we do not show how such a steady motion could be generated ; secondly, we do not prove that such a flame is stable. These are difficult questions which do not appear to have simple general answers. However, in the application to cordite we can appeal to experiment as a proof that such regimes are both possible and stable.

3.05. Propagation of plane reaction zone

Take an x -axis of reference perpendicular to the plane, with an origin moving with the reaction zone, so that relative to our axes of reference the unreacted medium moves from the direction of negative x and after passing through the reaction zone the products pass towards infinite x . All properties of the system are functions of x alone. When U is the velocity of the medium at any point, the rate at which any property y of a small given part of the medium varies with time is given by

$$\frac{Dy}{Dt} = \frac{\partial y}{\partial t} + U \frac{\partial y}{\partial x} = U \frac{dy}{dx} \quad 3,01$$

U is itself a function of x .

The quantities whose variation through the reaction zone are required are U , the velocity, V , the volume per unit mass, T , the temperature, and ϵ , the fraction the reaction has progressed towards completion at the plane x , so that of the gases passing this plane a fraction ϵ (by mass) consists of the products of reaction. We can immediately obtain a relation between U and V . If we consider the material moving along a cylinder with walls parallel to the x -axis and of unit

cross-section, it is apparent that the same mass is moving across any cross-section of this per unit time, and representing this by M , we have

$$M = U/V \quad 3,02$$

Since the pressure is constant, V must be a function of T and ϵ only, and is known from the equation of state for the medium with a given ϵ .

The energy crossing any normal cross-section of the cylinder must be a constant, or energy would accumulate or disappear between two sections. The energy flow is composed of

- (a) the intrinsic energy E per unit mass, transported by the mass flow,
- (b) the work done by the material on one side of the section by its pressure on the material on the other side of the section, and
- (c) the flow of heat by thermal conduction, described by a thermal conductivity λ .

The flow by conduction at large distances from the reaction zone will be zero at both sides. Denote the conditions at a large distance before the reaction zone by T_0 , V_0 , etc., and at large distances past as T_m , V_m , etc. Then we have

$$ME + pU - \lambda \frac{dT}{dx} = ME_m + pU_m = ME_0 + pU_0 \quad 3,03$$

which gives

$$\frac{\lambda}{M} \frac{dT}{dx} = E - E_m + p(V - V_m) = H - H_0 \text{ or } H - H_m \quad 3,04$$

where H is the total heat content per unit mass.

We need a further relation, which is supplied by considerations of reaction velocity. The homogeneous reaction rate, expressed as $D\epsilon/Dt$, will be a function of ϵ , V and T by our initial assumptions.* Hence we have

$$U \frac{d\epsilon}{dx} = \frac{D\epsilon}{Dt} = f(\epsilon, V, T) \quad 3,05$$

Equations 3,04 and 3,05 can be written in terms of ϵ and T alone, since H will be a known function of ϵ , T and V , and the last can be eliminated by using the equation of state. In this way we can obtain two differential equations in ϵ , x , and T which can be simplified by dividing one by the other, giving

$$\frac{d\epsilon}{dT} = \frac{\lambda f(\epsilon, T)}{M^2 V (H - H_m)} \quad 3,06$$

This is possible only because x does not appear except as dx . In more general cases than we are considering here, x may appear explicitly; this happens when the phenomena in the flame zone depend on the distance from the solid boundary. In such cases there is no point in forming 3,06. In our case, however, this step is useful because the problem of the flame speed can be solved from 3,06 alone. If distances in the flame zone are of interest the results can be substituted in 3,04, giving the relation between x and T or ϵ .

* This implies that the reaction rate at any point is determined by the local temperature, just as if the gas at that point were in a large enclosure at constant temperature. This is true only if the thickness of the reaction zone is large compared with the mean free path of molecules in it. It can be shown that this condition is satisfied in the flames outside propellants.

We require the integral of 3,06 which is such that $T = T_0$ when $\epsilon = 0$ and $T = T_m$ when $\epsilon = 1$. T_0 is the temperature at a large distance inside the unreacted medium, the initial temperature, which is known in any particular set of experiments. T_m follows from this by the relation

$$H_0 = H_m$$

where H_0 is the total heat content for $\epsilon = 0$, and H_m refers to $\epsilon = 1$.

T_m is the temperature of burning at constant pressure. In the application to cordite T_m must be distinguished from the temperature of explosion under constant-volume conditions (as in closed-vessel work).

Equation 3,06 is a first-order equation, and its solution is determined by the parameters of the equation, together with one pair of corresponding values of ϵ and T . The solution determined by the condition at T_0 will in general not fulfil the condition at the upper limit T_m . There will be one value of M for which both conditions hold; this determines the only velocity possible for a steadily moving reaction zone in the given medium. This value of M is a function of the other parameters in the equation.

The form of the equations ensures that ϵ and T remain constant beyond the point where $\epsilon = 1$ and $T = T_m$. This has the result that in finding M we can restrict our attention to the equation between ϵ and T . No matter whether the point ($\epsilon = 1$, $T = T_m$) is at a finite or an infinite distance, we can be sure that everywhere beyond this point the outgoing gases will be at the temperature T_m and will be completely reacted, which is necessary for a physically satisfactory reaction zone. At distances which are large compared with the effective thickness of the flame the gas may be subjected to cooling and consequent changes of composition, or it may be compressed against a barrier and so heated, but these cannot affect the rate of burning. The only influence which can have any effect on the rate is one which acts in the region where the reaction rate is appreciable.

The velocity of the reaction zone relative to the unburnt medium is MV_0 , which in the application to cordite is the rate of recession of the surface of the cordite. The corresponding relation between ϵ and T is the solution of 3,06 with the proper value of M ; finally the (x , T) relation can be found by substituting in 3,04. This provides a scale of distances for the variation of T and ϵ through the flame.

3.06. Equations for a special case

We now examine a special case which can be integrated explicitly by a method of successive approximations. This case corresponds to a simple form of the reaction rate which appears to be applicable to cordite. The method of successive approximations is not restricted to this case.*

We limit our examination to a zone in perfect gases with constant specific heats per unit mass. Though all these assumptions will be discussed more fully later, we may mention here that the temperatures at which the reaction does not proceed at an appreciable rate do not affect the rate of burning, and so we are assuming constancy of specific heat only at those high temperatures in the flame at which most of the reaction takes place. The assumption is therefore a good approximation for hot flames.

If Q_m is the heat of reaction at constant pressure at the temperature T_m of the final products, we have

$$H - H_m = (1 - \epsilon) Q_m + (T - T_m) \{ C_p' (1 - \epsilon) + \epsilon C_p \} \quad 3,07$$

* Corner has applied this method to the equations with diffusion, and Booth has used a similar technique in his work on reaction zones in pyrotechnic mixtures (A.R.D. Theoretical Research Report 25/45).

where C_p' is the specific heat of the reactant and C_p that of the products, both at constant pressure. It would be possible to integrate this case if the problem required this refinement, but since a simpler case is adequate for our purpose we shall put $C_p' = C_p = C$. We can also write Q instead of Q_m , since now the heat of reaction is independent of the temperature. Thus finally

$$H - H_m = (1 - \epsilon)Q + (T - T_m)C \quad 3,08$$

so that

$$\frac{\lambda}{M} \frac{dT}{dx} = (1 - \epsilon)Q + (T - T_m)C \quad 3,09$$

and substituting in 3,06,

$$\frac{d\epsilon}{dT} = \frac{\lambda f(\epsilon, T)}{M^2 V \{(1 - \epsilon)Q + (T - T_m)C\}} \quad 3,10$$

In a simple reaction in which molecules of molecular weight W give molecules of weight w , the equation of state is

$$pV = \left[\frac{1 - \epsilon}{W} + \frac{\epsilon}{w} \right] RT = (1 + n\epsilon) RT/W \quad 3,11$$

where $n = \frac{W}{w} - 1$, and R is the gas constant (82.06 atmos. c.c./mol. deg. C.).

If the reactant consists of more than one type of molecule with different molecular weights this equation will have the same form but with a different value of n .

For a second-order rate from a bimolecular reaction, $D\epsilon/Dt$ is, by definition of the rate order, proportional to $(1 - \epsilon)^2/V$, and empirically its dependence on temperature may be expressed by a factor $e^{-A/RT}$.

Hence

$$f(\epsilon, V, T) = \frac{D\epsilon}{Dt} = \frac{B(1 - \epsilon)^2 e^{-A/RT}}{V} \quad 3,12$$

The values of the constants will be discussed when the results are applied to particular cases.

Substituting in 3,10, we have

$$\frac{d\epsilon}{dT} = \frac{\lambda B (1 - \epsilon)^2 e^{-A/RT}}{M^2 V^2 \{(1 - \epsilon)Q + (T - T_m)C\}} \quad 3,13$$

Using 3,11

$$\frac{d\epsilon}{dT} = \frac{\lambda B (pW)^2 (1 - \epsilon)^2 e^{-A/RT}}{M^2 (1 + n\epsilon)^2 (RT)^2 \{(1 - \epsilon)Q + (T - T_m)C\}} \quad 3,14$$

3.07. Approximate solution of the equations in the special case

Near the hot boundary of the reaction zone, $T - T_m$ and $1 - \epsilon$ are small, and these terms determine the behaviour of the solution. All other functions of T and ϵ in this equation can be given the values corresponding to $T = T_m$ and $\epsilon = 1$. The equation thus simplified has

a solution which at large distances, where $T - T_m$ and $1 - \epsilon$ are sufficiently small, approaches that solution of the original equation satisfying the boundary condition that $T = T_m$ when $\epsilon = 1$. This (ϵ, T) relation can be used in the awkward coupling term $Q(1 - \epsilon) + C(T - T_m)$ but nowhere else in 3,14. The resulting equation can be integrated exactly. This provides a second approximation to the exact solution of 3,14. We do not go beyond this order of approximation, because comparison with step-by-step numerical integration of the exact equation has shown that the accuracy of the second approximation is ample for our purpose; moreover, the differential equation in the next approximation is as difficult to solve analytically as the original equation. It is not possible to stop at the extremely simple first approximation, because the error in the rate of burning is a factor of about three. The error in the second approximation depends chiefly on A/RT_m , and has not been more than 15 per cent. in the examples studied, in which A/RT_m has been as low as 4. For A/RT_m near 8, the rate is too low by about 5 per cent.

Write $1 - \epsilon = \xi$ and $T_m - T = \eta$. The first approximation is the solution of the equation

$$\frac{d\xi}{d\eta} = \frac{D\xi^2}{Q\xi - C\eta} \quad 3,15$$

where

$$D = \frac{\lambda B}{(1+n)^2} \left[\frac{pW}{MR} \right]^2 \frac{\exp(-A/RT_m)}{T_m^2} \quad 3,16$$

Write $k = C/D$ and $\theta = k/\xi = k/(1 - \epsilon)$.

Equation 3,15 can then be written

$$\frac{d\eta}{d\theta} - \eta = -\frac{Q}{D\theta}$$

of which we want the solution with $\theta = \infty$ at $\eta = 0$.

This is

$$\eta = T_m - T = -\frac{Q}{D} \exp(\theta) \text{Ei}(-\theta) \quad 3,17$$

where

$$\text{Ei}(-\theta) = \int_{\infty}^{\theta} \exp(-\theta) d\theta/\theta$$

which is the "exponential integral" and has been tabulated many times.*

Substituting in the $(T - T_m)$ term in 3,14

$$\frac{d\epsilon}{dT} = \frac{\lambda Bk}{Q\theta^2 G(\theta)} \left[\frac{pW}{MR(1+n\epsilon)} \right]^2 \frac{\exp(-A/RT)}{T^2}$$

where $G(\theta) = 1/\theta + \exp(\theta) \text{Ei}(-\theta)$.

* e.g., Jahnke and Emde, *Tables of functions*, 1933 Edn. p. 78 ; 1938 Edn. p. 1.

This integrates to

$$\int_0^{\infty} (1 + n - nk/\theta)^2 G(\theta) d\theta = \frac{\lambda BR}{AQ} \left[\frac{pW}{MR} \right]^2 \left[\exp(-A/RT_m) - \exp(-A/RT) \right] \\ = \frac{(1+n)^2}{k} \frac{CT_m}{Q} \frac{RT_m}{A} \left[1 - \frac{\exp(A/RT_m)}{\exp(A/RT)} \right] \quad 3,18$$

using 3,16.

This solution has been made to satisfy the boundary condition at the hot end of the flame, but does not necessarily do so at the beginning of the flame.

Imposing the condition that $\epsilon = 0$, i.e. $\theta = k$, when $T = T_0$ gives as the equation to determine M,

$$k \int_k^{\infty} \left[1 - \frac{nk}{(n+1)\theta} \right]^2 G(\theta) d\theta = \frac{CT_m}{Q} \frac{RT_m}{A} \quad 3,19$$

since $\exp(A/RT_0)$ is large compared with $\exp(A/RT_m)$.

This can be written

$$g_1(k) - \frac{2n}{n+1} g_2(k) + \left[\frac{n}{n+1} \right]^2 g_3(k) = \frac{CT_m}{Q} \frac{RT_m}{A} \quad 3,20$$

where

$$g_1(k) = k \int_k^{\infty} G(\theta) d\theta \\ g_2(k) = k^2 \int_k^{\infty} G(\theta) d\theta/\theta \\ g_3(k) = k^3 \int_k^{\infty} G(\theta) d\theta/\theta^2$$

These functions are tabulated in Table 3.01 for the whole range of k likely to be encountered in flames outside cordite.

To find the rate of burning M corresponding to given values of n , T_m , C , Q , A , B , p and W , we calculate the right side of 3,20, then solve for k by trial and error. Since $k = C/D$, we have finally

$$M^2 = \frac{\lambda B (pW)^2 k e^{-A/RT_m}}{C (RT_m)^2 (1+n)^2} \quad 3,21$$

Since 3,20 does not contain the pressure p , for a given reaction k is independent of p , and the rate of burning is therefore proportional to the pressure.

In using these equations one point must be noted. The gas constant R appears from two sources : as it enters from 3,11, the equation of state of the gas, it has to be in the units

$$\frac{(\text{unit of pressure}) \times (\text{unit of volume of a mole of gas})}{\text{unit of temperature}}$$

In other words, R is in the appropriate mechanical units. The activation energy A is conventionally given in heat units, as calories per mole, so the R associated with A is in heat units, namely calories per mole per degree. To prevent possible confusion we have written all the formulae in terms of R and A/R , so that R is in mechanical units where it stands alone; in A/R , which has the dimensions of temperature, A and R can be in any consistent units, and heat units will normally be used.

The relation between ϵ and T in the second approximation is

$$(1 - \epsilon) \left[g_1(\theta) - \frac{2n(1 - \epsilon)}{n + 1} g_2(\theta) + \left(\frac{n(1 - \epsilon)}{n + 1} \right)^2 g_3(\theta) \right] = \frac{CT_m}{Q} \frac{RT_m}{A} \left[1 - \frac{\exp(A/RT_m)}{\exp(A/RT)} \right] \quad 3,22$$

where

$$\theta = k/(1 - \epsilon).$$

For any set of values of A , T_m , Q , C and n , equation 3,20 gives k , which can be used in 3,22 to find the T corresponding to any given ϵ . The error in the (ϵ, T) curve is small: comparison with a numerical integration carried out with the accurate M showed that ϵ was too large by 3 per cent. at $\epsilon = 0.5$, and the error was everywhere of the same amount except at low temperatures. Here T tends to zero as the ϵ of the approximate solution tends to zero, whereas the numerical integration had been started with $\epsilon = 0$ at a "surface temperature" greater than zero.

This (ϵ, T) relation can be used to find a value of M which is several per cent. better than the second approximation itself. To do this we choose ϵ_1 and ϵ_2 in the neighbourhood of 0.4 and 0.6 respectively, and such that $k/(1 - \epsilon_1)$ and $k/(1 - \epsilon_2)$ occur in Table 3.01. Equation 3,22 gives the corresponding temperatures T_1 and T_2 , and hence we can estimate $d\epsilon/dT$ at $\frac{1}{2}(T_1 + T_2)$. Substitution into 3,13 gives M .

3.08. Variation of ϵ and T with distance in the special case

When the (ϵ, T) relation has been found this can be used in the equation of heat conduction 3,09 to give the (x, T) relation. This supplies the scale of distances for the variation of ϵ and T . Let the origin of x be taken at a temperature T_s . Then

$$x = \int_{T_s}^T \frac{\lambda dT}{M \{ (1 - \epsilon) Q + (T - T_m) C \}} \quad 3,23$$

where ϵ is expressed as a function of T . In the special case considered above, and in most possible cases, x will tend to infinity as T tends to T_m , and to negative infinity as T tends to T_0 . Theoretically, therefore, the reaction zone is of infinite thickness, though most of the reaction occurs in a small distance. To obtain a measure of the thickness it is convenient to take the distance between the points where $\epsilon = 0.1$ and 0.8 .

A first approximation to the (ϵ, x) relation can be found from the first approximation to the (ϵ, T) law. From 3,09 and 3,15,

$$\frac{d\xi}{dx} = - \frac{MD}{\lambda} \xi^2 \quad 3,24$$

with the solution

$$\frac{1}{1 - \epsilon} = \xi^{-1} = \frac{MDx}{\lambda} + \text{constant}$$

and therefore an infinite flame thickness.

To get a second approximation it is easiest to tabulate ϵ as a function of T , given by the second approximation, and then to carry out a numerical integration of 3,23.

In the first approximation the "thickness of the flame" is proportional to

$$\frac{\lambda}{MD} = \frac{RT_m(1+n)}{\rho W} \left(\frac{\lambda k}{CB} \right)^{\frac{1}{2}} \exp(A/2RT_m) \quad 3,25$$

As an example of the kind of result obtained, we show in Fig. 3.01 the value of ϵ and T as functions of distance through a reaction zone at 10 tons/sq. in. The activation energy is 25 kcal/mole; this and the other data are typical of those which are used in the application to cordites. In this case the (ϵ, T) relation was found by numerical integration of 3,14 and x was then calculated from 3,23. As boundary condition at the cool side of the flame, it was assumed that $\epsilon = 0$ at 750°K., though the diagram makes it clear that $d\epsilon/dT$ is so small in this region that the exact temperature assumed is of no importance. Actually a change of the temperature at which $\epsilon = 0$, from 1000°K. to 1200°K., produced in a typical example a decrease of only 1 per cent. in the rate M .

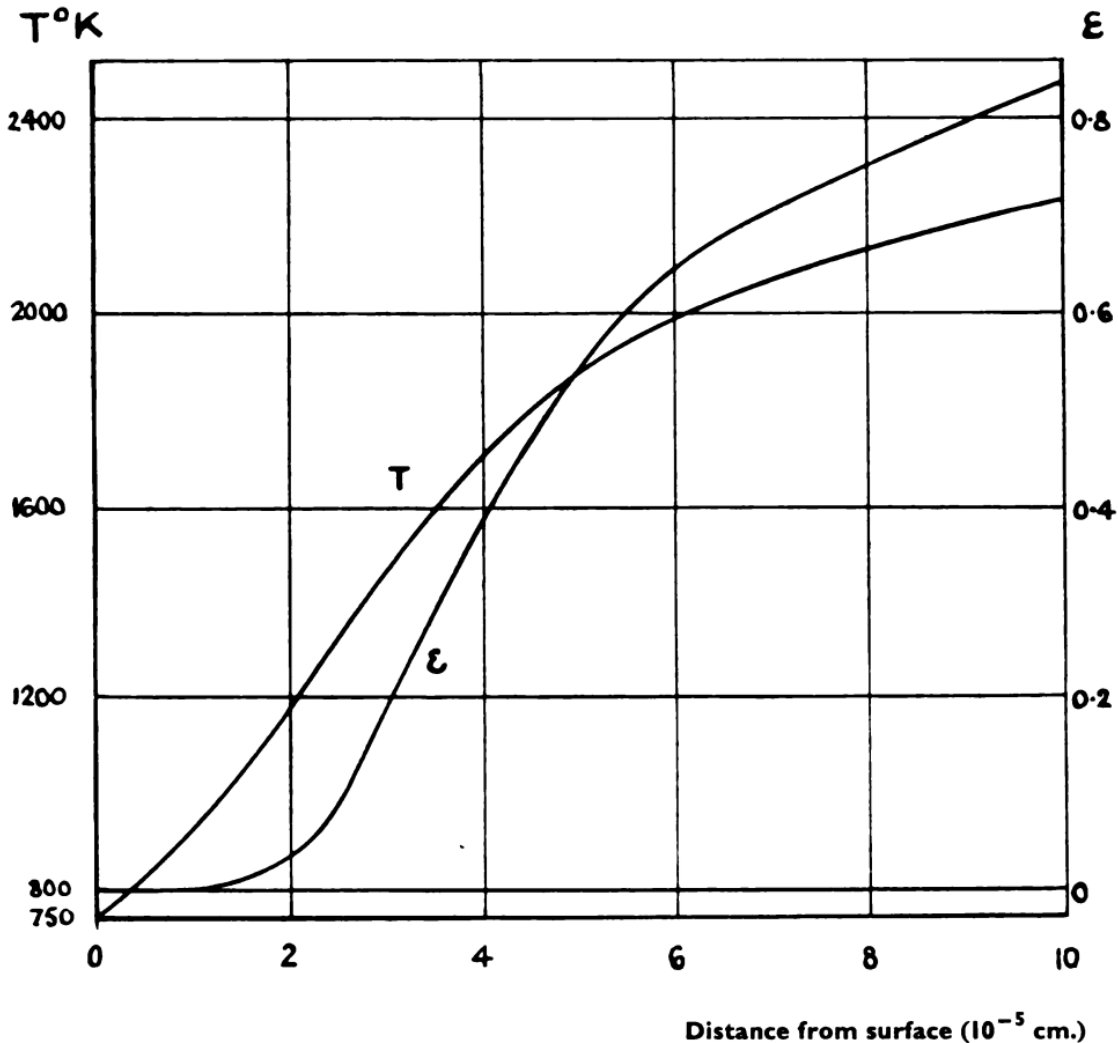

Fig. 3.01 Reaction zone of typical propellant at 10 tons/sq. in.

This diagram can be used at other pressures. For it can be shown that for a second-order reaction the distance between two assigned values of temperature is inversely proportional to the pressure. Hence the diagram can be regarded as valid for any pressure p tons/sq. in., giving ε and T as functions of $xp/10$.

Boys and Corner* have shown how, by combining the parameters in the general equations, one may obtain the exact dependence of the rate on certain parameters without finding an exact solution of the equations. The process is applicable to many possible forms of the reaction rate. Without going into the matter more closely here, we may say that the methods and aims are much the same as in the subject of similarity relations in internal ballistics, sketched in Section 11.08.

One result which is of special importance is that the rate of burning and the thickness of the flame are proportional to λ^{\dagger} . This is needed in the theory of erosion of cordite, and is true under very general assumptions; in fact, Corner[†] has shown that all one needs is the assumption that a mean value of λ can be used throughout the flame. In particular, this result holds for any form of the reaction rate, and not just for the second-order reaction studied in this section.

For a reaction zone typical of those encountered in the application to propellants, the distance between the planes where the reaction is 10 per cent. and 80 per cent. completed is about $8 \times 10^{-4}/p$ cm. This is least for reactions with high final temperatures, though the variation is only moderate; for two cordites with final temperatures of 2000°K. and 3000°K. the widths of the flame were found to be in the ratio 1 : 0.7.

For details of the choice of suitable specific heats, thermal conductivities, and reaction rates we must refer to the reports of Boys and Corner,[‡] where also are given notes on the numerical integration of the flame equations.

3.09. Application to the burning of cordite

It is assumed that the controlling rate in the burning of cordite is the rate of a gas reaction going on between the products of the initial decomposition of the propellant. Passing through the system normal to the cordite surface, we start with unreacted propellant at the initial temperature; there is a steep rise of temperature as we near the surface, and a corresponding decomposition into intermediate products. These are assumed to be of fairly low molecular weight and therefore form a vapour phase in which the slow, controlling reaction takes place. Since the rate of burning of cordite is roughly proportional to the pressure, we must suppose that we are dealing with a second-order reaction.

If the main reaction is not proceeding appreciably at the temperature of the surface (compared with its rate in the hotter parts of the flame), then the rate of burning will be independent of the surface temperature. The initial temperature of the propellant affects the rate of burning through its effect on T_m , not because it is the point where $\varepsilon = 0$. These remarks are justified by the analysis of the preceding section; the lower boundary condition that $\varepsilon = 0$ when $T = T_0$ is actually used in the form $\varepsilon = 0$ when e^{-A/RT_0} is practically zero, and we should get exactly the same results if we took $\varepsilon = 0$ at $T = T_1$, where T_1 is any temperature such that e^{-A/RT_1} is negligible. The rate of burning is not affected by the temperature variation before the controlling reaction has commenced appreciably, provided the same overall energy conditions are satisfied. Hence since we are assuming the main or slow reactions to take place entirely in the gaseous layer it is the velocity of propagation of this

* Boys and Corner, Proc. Roy. Soc. A. 197 (1949) 90; also AC 1139/IB 8.

† Corner, Proc. Roy. Soc. A. 198 (1949) 388; also A.R.D. Theoretical Research Report 1/43.

‡ Boys and Corner, AC 1139/IB8.

Corner, A.R.D. Theoretical Research Reports 1 and 2/43.

flame which determines the rate of burning of the cordite. The surface temperature will adjust itself to supply the necessary gases at this rate, provided that this is possible at some temperature below the range in which the main reaction velocity is appreciable.

The variation of temperature in the solid before appreciable reaction occurs is governed by

$$\frac{\lambda_s}{M} \frac{dT}{dx} = C_s (T - T_0) \quad 3,26$$

where C_s is the specific heat of the solid at constant pressure and λ_s is its thermal conductivity. If the primary decomposition in the solid evolves or absorbs only a small heat, 3,26 will still be an approximation. Using it as such, taking a surface temperature T_s , and a mean C_s , we have

$$\frac{T - T_0}{T_s - T_0} = \exp \left[\frac{MC_s x}{\lambda_s} \right]$$

where x is measured from the surface into the solid. For cordite λ_s is of order 8×10^{-4} cal. per sq. cm. per (deg. per cm.). Taking T_s as 750°K ., and T_0 as 300°K ., we find that for a typical propellant at p ton/sq.in. the temperature has fallen to 315°K . at a distance of no more than $4 \times 10^{-3}/p$ cm. from the surface. Thus the "hot zone" in the cordite is rather larger than the effective breadth of the reaction zone outside, and the ratio of these lengths is independent of the pressure.

By writing down the equation for $d\epsilon/dx$ from the unimolecular primary decomposition of NG or NC, the equation between ϵ and T can be set up just as in the previous section. It can be shown in this way that the primary decomposition is almost complete at 750°K . The argument is only rough, since the experimental knowledge of the reaction refers to low temperatures and small values of ϵ . However, it can be concluded that the cordite decomposes long before it can reach a temperature at which unreacted cordite would sublime or vaporise.

In the previous sections we have assumed that the pressure is constant through the flame. By calculating the momentum acquired by the product gases in their passage through the zone, it is easy to show that this condition is satisfied to a very high accuracy for flames outside cordite.

As disposable constants in our equations we have (i) the molecular weight of the intermediate products, which is probably of order 75, (ii) the fraction of the total heat of reaction liberated in the gas phase, and (iii) the activation energy A . The heat of the controlling reaction is not known, but must be a substantial part of the whole heat of reaction. The activation energy has a strong influence on the rate of burning, and there is little chemical evidence on its value.

The other quantities appearing in the equations of the flame zone can be calculated from the propellant composition. For example, the effective specific heat and thermal conductivity can be obtained from the known final products and the assumed intermediate products; the latter choice is not of great importance for the calculation. Finally, an upper limit for B can be found from the kinetic theory of gas reactions. This must be reduced by a factor $1/\alpha$ which allows for the fact that the intermediate products are a mixture of some complexity. Only part of the collisions will be between a molecular pair which can take part in the controlling reaction. The result is

$$B = \frac{4N\sigma^2}{W\alpha} \left(\frac{\pi RT'}{W} \right)^{\frac{1}{2}} \quad 3,27$$

where σ is the collision diameter of the reactants, N is Avogadro's number, and T' is a mean temperature in the reaction zone.

3.10. Comparison with experimental results

It was found that the closed-vessel rates of burning of a number of British cordites could be represented by taking $\alpha = 100$, an implausibly large value which was necessary to keep the apparent activation energy approximately the same for all the cordites. A later theory included diffusion, which reduces the rate of burning of a given gas mixture. With this theory a value of $\alpha = 10$ gave satisfactory results. This amounts to taking one-tenth of the collisions as suitable for the rate-controlling reaction. The mean activation energy for seven propellants not containing mineral jelly was 26.4 kcal/mole, which is reasonable for reactions between unsaturated organic molecules. The activation energies had a total spread of 1.8 kcal/mole, and it was shown that this range was not much larger than that introduced by unavoidable uncertainties in the other constants used. The dependence on initial temperature is also reproduced fairly well, although the theoretical value appears to be too small.

The following table gives a comparison of observed and theoretical rates, the latter being calculated from a single set of constants for all the examples.

COMPARISON OF OBSERVED AND CALCULATED RATES OF BURNING
All rates are in inches/sec., for a single surface, at 10 tons/sq. in. and 300°K.
 $A = 26.4$ kcal/mole ; $\alpha = 10$.

| Cordite | T_m , °K. | Theory with diffusion | Observed, closed vessel |
|---------|-------------|-----------------------|-------------------------|
| HW. | 3050 | 8.0 | 7.9 |
| HSC. | 3050 | 8.0 | 7.6 |
| W. | 2700 | 6.8 | 5.9 |
| SC. | 2500 | 5.7 | 5.0 |
| Bofors. | 2250 | 4.1 | 3.9 |
| RDQ. | 2230 | 3.6 | 4.2 |
| RDNA. | 1900 | 2.6 | 3.2 |

In these calculations it was assumed that the whole of the heat of the reaction was liberated in the controlling process. The relative rates for different propellants are not sensitive to this assumption.

This single-reaction theory is inadequate at pressures below 2 tons/sq. in., where reactions in the solid have important effects. Transfer of energy through the flame by radiation has been neglected in this theory. Experiment has shown the effect to be of some importance under rocket conditions, but at gun pressures the effect on the rate is believed to be only a few per cent.

3.11. Subsidiary effects at high pressure

At very high pressures the following effects enter :—

(1) COMPRESSIBILITY OF CORDITE

The theory gives M , the rate of burning in mass per second per unit of true area. The rate used in internal ballistics is an apparent rate, based on the area at atmospheric pressure. In other words, the practical rate takes no account of the real reduction of area when burning

under high pressure. This practical rate is of course the more convenient for internal ballistics, and we must correct the theoretical rate before comparison. This effect was pointed out by Dr. H. H. M. Pike. It is easy to show that the apparent rate is reduced by the order of 10 per cent. at 20 tons/sq.in.

(2) CO-VOLUME EFFECTS

The theory assumes that the gases in the reaction zone obey the perfect gas laws. It has been shown that at 20 tons/sq.in. the rate falls about 30 per cent. below that calculated from the perfect gas approximation.

(3) THERMAL CONDUCTIVITY

It has been assumed that the thermal conductivity of the gas in the reaction zone is independent of pressure. This is true at low pressures, but as the pressure goes up the conductivity must eventually approach that of a liquid, that is, it must increase. It has been shown that the rate may be expected to be increased by about 20 per cent. at 20 tons/sq. in.

(4) PRESSURE-EFFECT ON SPECIFIC HEAT

The specific heat of the gases increases with pressure. This alters two quantities in the equations: it increases the average specific heat, and reduces the maximum temperature T_m . The magnitude of these effects can be calculated from Corner's tables of pressure-corrections,* and in this way it has been found that this correction reduces the rate of burning at 20 tons/sq. in. by 20—30 per cent.

(5) CHANGE OF REACTION RATE

The formulae we have used for theoretical reaction velocities refer to molecular collisions in a perfect gas. At high densities the environment of any particular molecule tends to become less impermanent, and its motion changes from random motion with infrequent collisions, to an oscillation in a "cell" with occasional escapes to another. This would be expected to alter the number of collisions effective in producing reaction, and in general this is so, but theoretical investigations have led to the conclusion that the effect is not likely to surpass, say, 50 per cent. It is not possible to estimate the effect as yet. All we can do is to give this reminder that such an effect probably exists.

(6) DIFFUSION

At normal pressures the diffusion coefficient, D , is known to be inversely proportional to the pressure p . This has been used in the theory with diffusion, and is essential for the result that the rate is still proportional to the pressure when diffusion is included. At pressures of order 20 tons/sq.in. one must expect a change in Dp , probably a decrease, tending to increase the rate of burning by about 10—20 per cent.

To summarise these effects, we may say that on balance they tend to reduce the ratio M/p at high pressures, by an amount which can be of order 20 per cent. at 20 tons/sq.in. The observed effect is the sum of a number of effects with opposite signs, and there is no reason why all propellants should show the same behaviour at high pressures. A rate increasing faster than the pressure is not excluded, but seems unlikely.

3.12. Theory of the erosion of cordite

The rate of burning of cordite is not simply a function of the pressure on its surface, but depends also on the transverse velocity of gas across it. The rate appears to be independent of the nature or temperature of this main stream, except in so far as these alter the hydrodynamic nature of the flow (by altering the Reynolds number, for instance). In any given apparatus

* Corner, Proc. Phys. Soc. 58 (1946) 737 ; also A.R.D. Theoretical Research Report 8/43 ; AC 5646/BAL 147.

the rate of burning can be expressed as a function of pressure and velocity ; the differences observed between experiments in different set-ups are sufficient to suggest that the gas velocity is not the real variable involved. It is probable that the turbulence is the underlying factor controlling the " erosion " of the cordite, and that the velocity at points in a given apparatus is simply a measure of the turbulence there.

Erosion of cordite was first studied properly in connection with high-performance rockets, in which it is of great importance. It had, however, been noticed earlier in partly-burnt grains of tubular and multitubular gun propellant. Its significance for the theory of internal ballistics is indicated in Sections 4.10 and 5.11 ; here we shall merely mention the early effort to explain the effect, made by Lennard-Jones and Corner.*

They assumed that the most important part of the effect came from the turbulence increasing the effective heat conductivity in the reaction zone outside the cordite ; taking the simple theory sketched in Section 3.04, they solved the problem for flow down a cylindrical conduit through a slab of cordite. Their formulae have not been found quantitatively successful at rocket pressures, but this is not surprising ; no single-reaction theory appears to be sufficient to cover burning at such low pressures, and moreover diffusion was neglected, which Corner† has shown must make a considerable difference to the results. Qualitatively, their results showed a rate varying with velocity to roughly the right extent, and they were able to show that erosion should decrease rapidly on going to hotter propellants. This has since been confirmed by experiment. Physically, the effect can be thought of as a shrinking of the flame nearer to the solid cordite ; since there is a laminar layer close to the surface in which turbulence does not act and in which therefore the conductivity is normal, the moderate shrinking of the flame causes an exaggerated decrease of its sensitivity to turbulence. Indeed, it is possible to estimate the characteristics of a cordite which would show practically no erosion ; this propellant would be hotter than any present propellant, though not by any striking amount.

The theory of the erosion of cordite could certainly be developed considerably beyond its present point, which lags behind the stage reached by the theory of ordinary burning.

* Lennard-Jones and Corner, AC 1173/IB19 ; also Corner, Trans. Fara. Soc., 43 (1947) 635.

† Corner, A.R.D. Theoretical Research Report 1/43.

CHAPTER IV

THE FORM FUNCTION

4.01. The law of burning

The manner in which the charge burns is considered in the following sections. For present purposes we shall consider that the charge consists of a number of geometrically similar pieces of propellant (usually referred to as propellant grains). The outer layers of these grains are brought to the temperature of ignition (about 170°C.) by the heat supplied from the igniter. With a well-designed ignition system, each grain will be ignited over its whole surface in a very short time-interval and we suppose here that all parts of the surface of the grains reach the ignition temperature simultaneously. The propellant gases are evolved at a high temperature and the heat from these gases brings successive layers of the grains to the temperature of ignition. Careful control during manufacture ensures that the grains are very nearly homogeneous and there is little reason why they should burn preferentially in any particular direction. We assume therefore that the surface of each grain recedes parallel to itself as burning proceeds.

The law of burning by parallel layers is known as Piobert's law and is generally adopted by internal ballisticians. Some confirmation that such a law is nearly obeyed in practice is obtained by firing charges such that the propellant is not all burnt while the shot is still in the bore : pieces of burning propellant are thrown from the gun, burning is arrested and the partially burnt pieces are recovered. The shape of such unburnt grains is, in general (but see Sections 3.12 and 4.10), found to be very well preserved. In other words, simultaneous ignition over the whole surfaces of the grains and burning by parallel layers seem to be reasonable assumptions.

4.02. The theoretical form function

Defining the "size" D of the propellant grain as the least thickness to be burnt through for complete combustion of the grain,* denoting by f the fraction of D remaining at time t , by z the fraction of weight burnt at time t and by S the surface area of the grain at this instant, it is possible to relate z to f or S to z . The relationships depend on the geometrical shape of the grain and it is British practice to use the (z, f) relation while some continental ballisticians employ the (S, z) relation. Either relation is known as the *form function*.

We can write therefore $z = \varphi(f)$ and since $z = 0$ when $f = 1$ and $z = 1$ when $f = 0$,

$$z = \varphi(f) = (1 - f)(1 + \theta f) \quad 4,01$$

where θ is a function of f .

The various forms assumed by $\varphi(f)$ for the shapes of propellant in common use are discussed below. Since S is clearly proportional to (dz/df) and since initially $S = S_0$ (say) when $f = 1$, the (S, z) relation is easily obtained from the equation

$$S/S_0 = (dz/df)/(dz/df)_{f=1} \quad 4,02$$

We shall see that θ is practically constant for shapes in general use ; the (S, z) relation then takes the form

$$S/S_0 = [1 - 4\theta z/(1 + \theta)^2]^{\frac{1}{2}} \quad 4,03$$

* The web of multitubular grain is usually denoted by D and called the "size," but the above definition does not hold in this case.

When θ is positive the burning surface steadily decreases ; burning is then said to be *degressive* and shapes with positive θ are described as *degressive shapes*. When θ is negative the surface increases and the burning is said to be *progressive*.

4.03. Cylindrical (often called "cord")

Here D is the diameter and if we assume the length of the stick to be λD , the initial volume of the cylinder is $\pi\lambda D^3/4$. At time t , the diameter is fD and, assuming burning takes place by parallel layers, the length will be $\lambda D - (1-f)D$. Hence at time t , the volume remaining is $(\lambda - 1 + f) \pi f^2 D^3/4$.

Weights being proportional to volumes, the fraction burnt is therefore given by—

$$\begin{aligned} z &= (\text{Initial volume} - \text{volume remaining at time } t)/(\text{Initial volume}) \\ &= \{\pi\lambda D^3/4 - (\lambda - 1 + f) \pi f^2 D^3/4\}/(\pi\lambda D^3/4) \\ &= (1 - f) (1 + f + f^2/\lambda) \end{aligned} \quad 4,04$$

In this case z is a cubic in f and the burning is sometimes referred to as being three-dimensional. Usually, however, the grains are long compared with their diameter* and f^2/λ is therefore small. If we neglect this term, we can write, for long cords

$$z = (1 - f) (1 + f) \quad 4,05$$

and this is the form function usually adopted for propellants in cord form.

From 4,03 we have, since $\theta = 1$,

$$S/S_0 = (1 - z)^t \quad 4,06$$

giving the form function usually adopted by continental ballisticians. With this shape, it is clear that the burning surface decreases as burning proceeds.

4.04. Tubular

Let the wall-thickness of the tube be D , the mean radius R and the length λD . At time t , the wall thickness is fD and the cross-sectional area is therefore $2\pi fDR$. The length at the same moment is $\lambda D - (1-f)D$, hence the volume is $2\pi D^2 R f (\lambda - 1 + f)$. The initial volume, i.e., the volume when $f = 1$ is $2\pi D^2 R \lambda$. Hence the fraction burnt at any moment is

$$\begin{aligned} z &= 1 - f (\lambda - 1 + f)/\lambda \\ &= (1 - f) (1 + f/\lambda) \end{aligned} \quad 4,07$$

For long tubes, λ is large and we have

$$z = 1 - f \quad 4,08$$

so that here $\theta = 0$. Hence, from 4,03,

$$S/S_0 = 1$$

and in this case the burning surface remains constant.

* λ is greater than 200 in many Service charges.

It is worth noticing that for tubes of length equal to the annulus ($\lambda = 1$), the form function 4,07 reduces to

$$z = (1 - f) (1 + f)$$

and such tubes, theoretically, burn precisely like long cords.

4.05. Slotted tube

We assume that the tube is long compared with the wall thickness (this is usually the case in practice) so that decrease in length during burning can be neglected. The slot is assumed to be formed by two radii inclined at an angle 2ω .

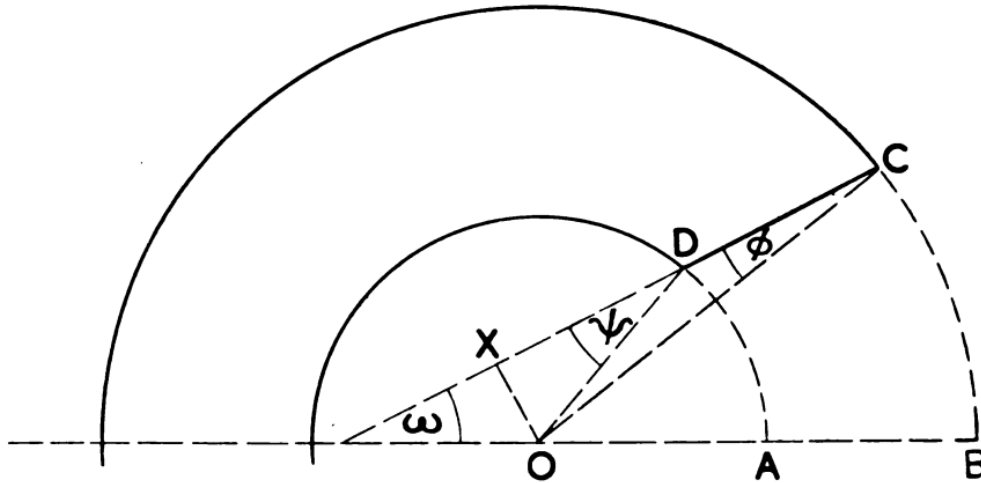

Fig. 4.01

Assuming burning by parallel layers, a side of the slot will be as shown at CD in Fig. 4.01. If r_1 and r_2 are the radii at any moment and R is the mean radius

$$r_1 = R + \frac{1}{2}fD \quad r_2 = R - \frac{1}{2}fD \quad 4,09$$

If OX is perpendicular to CD from the centre O,

$$OX = \frac{1}{2} (1 - f) D = r_1 \sin \varphi = r_2 \sin \psi \quad 4,10$$

where φ and ψ are the angles shown.

The cross-sectional area remaining at any moment is

$$r_1^2 (\pi - \omega - \varphi) - r_2^2 (\pi - \omega - \psi) - r_1 r_2 \sin (\psi - \varphi)$$

The initial cross-sectional area is given by $\Omega = 2RD (\pi - \omega)$ and

$$(r_1^2 - r_2^2) (\pi - \omega) = 2fRD (\pi - \omega) = f\Omega$$

Hence, neglecting the decrease in length of tube, the fraction burnt at any moment is

$$z = 1 - f + [r_1^2 \varphi - r_2^2 \psi + r_1 r_2 \sin (\psi - \varphi)]/\Omega \quad 4,11$$

Since φ and ψ are reasonably small, a good approximation to the bracketed term is obtained by replacing the angles by their sines and putting the cosines equal to unity. The bracketed term then becomes

$$\begin{aligned} & r_1^2 \sin \varphi - r_2^2 \sin \psi + r_1 r_2 (\sin \psi - \sin \varphi) \\ &= (r_1 - r_2) (r_1 \sin \varphi + r_2 \sin \psi) \\ &= f (1 - f) D^2 \end{aligned}$$

using equations 4,09 and 4,10.

Hence

$$z = (1 - f) (1 + f D^2/\Omega) \tag{4,12}$$

and

$$\theta = D^2/\Omega$$

The (S, z) relation follows at once from 4,03.

The error in the value of the bracketed term due to the above approximation is

$$r_1^2 (\varphi - \sin \varphi) - r_2^2 (\psi - \sin \psi) + r_1 r_2 \sin \varphi (1 - \cos \psi) - r_1 r_2 \sin \psi (1 - \cos \varphi)$$

and an estimate of its size may be obtained by retaining terms of the third order in $\sin \varphi$ and $\sin \psi$. It then becomes

$$\frac{1}{6} r_1^2 \sin^3 \varphi - \frac{1}{6} r_2^2 \sin^3 \psi + \frac{1}{2} r_1 r_2 \sin \varphi \sin^2 \psi - \frac{1}{2} r_1 r_2 \sin \psi \sin^2 \varphi$$

which, using 4,09 and 4,10, reduces to

$$\frac{f (1 - f)^3 D^4}{24 (R^2 - \frac{1}{4} f^2 D^2)}$$

Dividing by Ω gives the corresponding error in z as

$$\frac{f (1 - f)^3 D^3}{48R (R^2 - \frac{1}{4} f^2 D^2) (\pi - \omega)}$$

This is zero when $f = 0$ and 1 and the maximum value of $f(1 - f)^3$ for $1 > f > 0$ is about 0.1 ; D/R is usually about unity and $\pi - \omega$ is about 3 . The value of this term, therefore, is not likely to exceed 0.001 . Terms of higher order will be correspondingly smaller and we conclude that the approximation is adequate.

4.06. Ribbon

Here D is the thickness and, if the width of the ribbon is μD and its length λD , the initial volume is $\lambda \mu D^3$ and the volume at time t is $\{\lambda D - (1 - f) D\} \{\mu D - (1 - f) D\} f D$.

Hence,

$$\begin{aligned} z &= 1 - f (\lambda - 1 + f) (\mu - 1 + f) / (\lambda \mu) \\ &= (1 - f) [1 + f (\mu^{-1} + \lambda^{-1}) - f (1 - f) / (\lambda \mu)] \end{aligned} \tag{4,13}$$

Generally, λ will be large and we can write

$$z = (1 - f) (1 + f/\mu) \tag{4,14}$$

4.07. Square flake

This is a particular case of ribbon in which $\lambda = \mu$, and as the side of the square is usually large compared with the thickness of the flake, equation 4,13 gives, neglecting $1/\mu^2$,

$$z = (1 - f) (1 + 2f/\mu). \quad 4,15$$

4.08. Multitubular

Here the grain consists of fairly short cylinders pierced by seven equally spaced holes parallel to the length of the cylinder. The specification states that the diameters of the holes are 0.1 that of the cylinder and the length of the cylinder is 2.25 times that of its diameter.

The appearance of the end section of a grain is shown in Fig. 4.02. Denoting the diameters of the holes by d and the distance between any two holes and between any of the outer six holes and the curved surface of the grain by D (called the web) we note that the grain is not all burnt when a distance D has been burnt through. Using, as usual, f for the fraction of D remaining at time t , we see that, when $f = 0$, twelve curvilinear triangular prisms (called "slivers") remain unburnt. It is convenient to work out the (z, f) relation in two stages —(i) before the web is burnt, (ii) during the burning of the slivers.

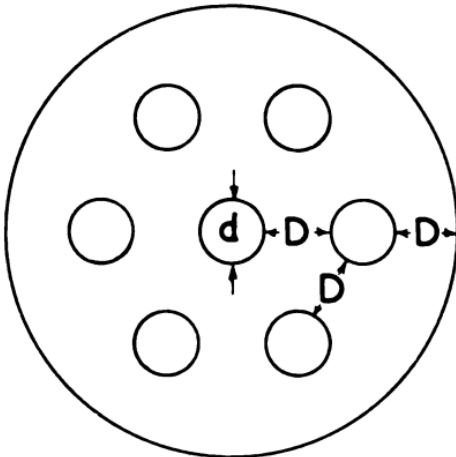

Fig. 4.02

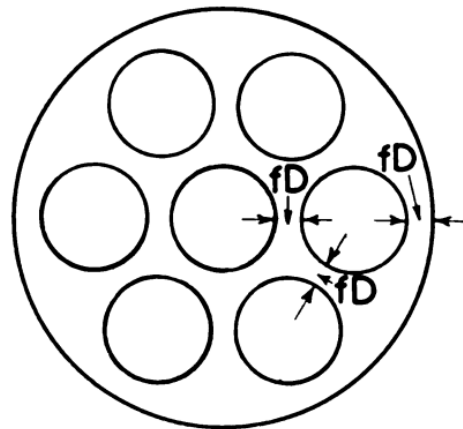

Fig. 4.03

(i) BEFORE THE WEB IS BROKEN DOWN

The outer diameter is $(4D + 3d)$ and since this equals $10d$, we have $D = 1.75d$. The length of the grain is, say, λD and since this is 2.25 times the outer diameter, we deduce that $\lambda = 12.86$. The original volume of the grain is $\pi\lambda D [(10d)^2 - 7d^2]$, which, on substituting for λ and D , is $1644d^3$. The volume when a fraction f of D remains (cross-section shown in Fig. 4.03) is

$$\begin{aligned} & \frac{1}{4}\pi [\lambda D - (1 - f) D] \{ [10d - (1 - f) D]^2 - 7 \{ d + (1 - f) D \}^2 \} \\ & = (246.4 + 1590f - 167.2f^2 - 25.25f^3) d^3 \end{aligned}$$

on substituting for λ and D . Hence

$$\begin{aligned} z &= .850 - .967f + .102f^2 + .015f^3 \\ &= (1 - f) (.850 - .117f - .015f^2) \end{aligned} \quad 4,16$$

This is the (z, f) relation during the first stage of the burning, and by putting $f = 0$, we see at once that 85 per cent. of the grain has been burnt when the web is consumed.

The (S, z) relation, if required, can be found immediately from equations 4,02 and 4,16.

We find

$$S/S_0 = 1.347 - .284f - .063f^2$$

Computation from this and 4.16 gives

| | | | | | | | | | | | |
|---------|-------|-------|-------|-------|-------|-------|-------|-------|-------|-------|-------|
| f | 1.0 | 0.9 | 0.8 | 0.7 | 0.6 | 0.5 | 0.4 | 0.3 | 0.2 | 0.1 | 0.0 |
| z | .000 | .073 | .149 | .229 | .310 | .394 | .481 | .571 | .662 | .755 | .850 |
| S/S_0 | 1.000 | 1.040 | 1.079 | 1.117 | 1.154 | 1.189 | 1.223 | 1.256 | 1.288 | 1.318 | 1.347 |

(ii) AFTER THE WEB HAS BEEN CONSUMED

In Fig. 4.04, O, A and B are the centres of the central and two of the outer holes. The triangle OAB is clearly equilateral of side $2a = D + d = 2.75d$. At the beginning of this stage the curvilinear triangles DEF, DE'F' remain, the radii of the sides DF, FE, ED, DF' and DE' being a , while that of E'F' is $3a$.

As burning proceeds the triangle DEF shrinks into the triangle XYZ, while the triangle DE'F' shrinks into PQR; these triangles are formed by circular arcs concentric with the corresponding arcs forming the sides of the triangles DEF, DE'F'. When the radius of the side XZ is r , that of PQ is r , while that of QR is $3a - (r - a)$, i.e., $4a - r$, since burning is assumed to be by parallel layers.

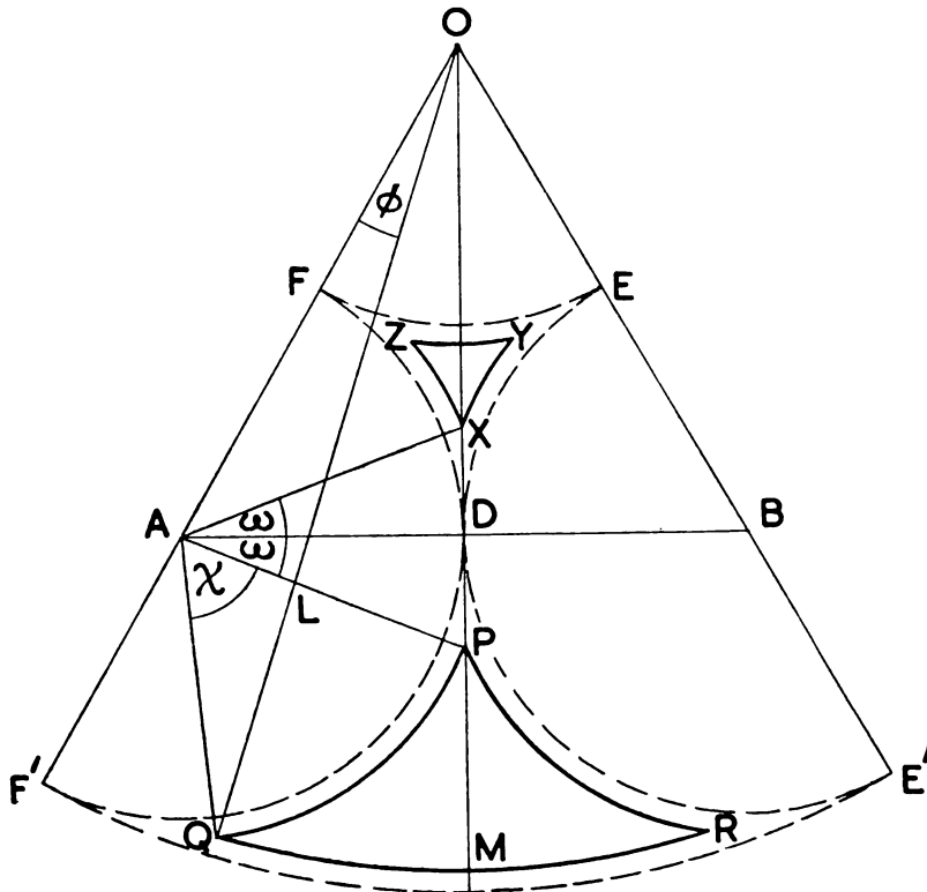

Fig. 4.04

If χ , ω and φ are the angles shown, then clearly $r = a \sec \omega$. The triangle OAQ enables χ and φ to be expressed in terms of ω , thus

$$\cos \varphi = \frac{(2a)^2 + (4a - r)^2 - r^2}{4a(4a - r)} = \frac{5 - 2 \sec \omega}{4 - \sec \omega} \quad 4,17$$

$$\cos (\pi/3 + \chi + \omega) = \frac{(2a)^2 + r^2 - (4a - r)^2}{4ar} = 2 - 3 \sec \omega \quad 4,18$$

Complete combustion of the grain occurs when $\varphi = 30^\circ$ and equation 4,17 then gives

$$\frac{5 - 2 \sec \omega}{4 - \sec \omega} = \frac{1}{2}\sqrt{3},$$

leading to $\omega = 42^\circ 25'$. During this stage of burning ω therefore varies from 0° to $42^\circ 25'$ and using equations 4,17, 4,18 we find

| ω | ω (radians) | χ | χ (radians) | φ | φ (radians) |
|----------------|--------------------|-----------------|------------------|----------------|---------------------|
| 0° | ·0000 | $120^\circ 00'$ | 2·0944 | $0^\circ 00'$ | ·0000 |
| 5° | ·0873 | $106^\circ 20'$ | 1·8559 | $2^\circ 55'$ | ·0509 |
| 10° | ·1745 | $92^\circ 38'$ | 1·6168 | $5^\circ 51'$ | ·1021 |
| 15° | ·2618 | $78^\circ 52'$ | 1·3765 | $8^\circ 51'$ | ·1545 |
| 20° | ·3491 | $65^\circ 00'$ | 1·1345 | $12^\circ 01'$ | ·2097 |
| 25° | ·4363 | $50^\circ 58'$ | 0·8896 | $15^\circ 22'$ | ·2682 |
| 30° | ·5236 | $36^\circ 44'$ | 0·6411 | $18^\circ 59'$ | ·3314 |
| $32^\circ 30'$ | ·5672 | $29^\circ 31'$ | 0·5152 | $20^\circ 52'$ | ·3642 |
| 35° | ·6109 | $22^\circ 14'$ | 0·3881 | $22^\circ 59'$ | ·4012 |
| $37^\circ 30'$ | ·6545 | $14^\circ 51'$ | 0·2592 | $25^\circ 14'$ | ·4404 |
| 40° | ·6981 | $7^\circ 20'$ | 0·1280 | $27^\circ 32'$ | ·4806 |
| $42^\circ 25'$ | ·7403 | $0^\circ 00'$ | 0·0000 | $30^\circ 00'$ | ·5236 |

As r and ω increase, the length of the triangular prisms is given by

$$L = (\lambda - 1) D - 2(r - a)$$

since $L = (\lambda - 1) D$ at the beginning of this stage, and burning proceeds for a distance $(r - a)$ at each end. Writing $D = 1·75d$, $\lambda = 12·86$, $2a = 2·75d$, $r = a \sec \omega$, we have

$$L = (23·5 - 2·75 \sec \omega) d \quad 4,19$$

Computation gives

| ω | L/d | ω | L/d | ω | L/d |
|----------|-------|----------|-------|----------|-------|
| 0° | 20.75 | 20° | 20.57 | 35° | 20.14 |
| 5° | 20.74 | 25° | 20.47 | 37° 30' | 20.03 |
| 10° | 20.71 | 30° | 20.32 | 40° | 19.91 |
| 15° | 20.65 | 32° 30' | 20.24 | 42° 25' | 19.77 |

The area of the triangle XYZ is given by

$$\begin{aligned} \Delta XYZ &= \Delta ABC - 6 \Delta AXD - 3 \text{sector AXZ} \\ &= 1.891 d^2 [\sqrt{3} - 3 \tan \omega - 3 (\pi/6 - \omega)] \end{aligned} \quad 4,20$$

Computation gives

| ω | $\Delta XYZ/d^2$ | ω | $\Delta XYZ/d^2$ |
|----------|------------------|----------|------------------|
| 0° | .3050 | 20° | .0893 |
| 5° | .2852 | 25° | .0270 |
| 10° | .2333 | 30° | .0000 |
| 15° | .1638 | | |

Denoting the volume of these prisms by $V(xyz)$,

$$V(xyz)/d^3 = (6 L/d) (\Delta XYZ/d^2) \quad 4,21$$

and the tabulated values permit computation of $V(xyz)$.

There now remain to be calculated the volumes of the six prisms typified by PQR. We have

$$\Delta PQR = 2 \Delta PQM = 2 [\text{sector OQM} - \Delta OLP - \text{sector APQ} + \Delta ALQ] \quad 4,22$$

But,

$$\text{sector OQM} = \frac{1}{2} (4a - r)^2 (\pi/6 - \varphi) = \frac{1}{2} a^2 (4 - \sec \omega)^2 (\pi/6 - \varphi) \quad 4,23$$

and from the triangle ALO,

$$OL = 2a \sin (\pi/3 + \omega) / \sin (\pi/3 + \omega + \varphi)$$

and

$$OP = OD + DP = a (\sqrt{3} + \tan \omega)$$

Hence

$$\Delta OLP = \frac{a^2 (\sqrt{3} + \tan \omega) \sin (\pi/3 + \omega) \sin (\pi/6 - \varphi)}{\sin (\pi/3 + \omega + \varphi)} \quad 4,24$$

and the table giving φ in terms of ω permits the tabulation of Δ OLP.
Also,

$$\text{sector APQ} = \frac{1}{2} r^2 \chi = \frac{1}{2} a^2 \chi \sec \omega \quad 4,25$$

and with the help of the table giving χ in terms of ω , we can tabulate the sector APQ. Finally, the triangle ALO gives

$$AL = 2a \sin \varphi / \sin (\pi/3 + \omega + \varphi)$$

and

$$\begin{aligned} \Delta \text{ ALQ} &= ra \sin \varphi \sin \chi / \sin (\pi/3 + \omega + \varphi) \\ &= a^2 \sec \omega \sin \varphi \sin \chi / \sin (\pi/3 + \omega + \varphi) \end{aligned} \quad 4,26$$

giving Δ ALQ in terms of ω when the numerical relations between φ , χ and ω are used. Equations 4,22 to 4,26 enable the tabulation of the area of the triangle PQR to be performed, the substitution $a = 1.375d$, giving Δ PQR/ d^2 in terms of ω . The results are :—

| ω | Δ PQR/ d^2 | ω | Δ PQR/ d^2 | ω | Δ PQR/ d^2 |
|----------|---------------------|----------|---------------------|----------|---------------------|
| 0° | 1.675 | 20° | 1.032 | 35° | 0.199 |
| 5° | 1.618 | 25° | 0.752 | 37° 30' | 0.096 |
| 10° | 1.493 | 30° | 0.458 | 40° | 0.025 |
| 15° | 1.286 | 32° 30' | 0.326 | 42° 25' | 0.000 |

Denoting by $V(pqr)$ the volumes of the six triangular prisms typified by PQR, we have

$$V(pqr)/d^3 = (6 L/d) (\Delta \text{ PQR}/d^2) \quad 4,27$$

and we can thus tabulate $V(pqr)/d^3$ in terms of ω .

The fraction z burnt is then given by

$$z = 1 - [V(pqr) + V(xyz)]/1644d^3 \quad 4,28$$

$1644d^3$ being the original volume of the grain. Equations 4,28, 4,27, 4,21, 4,19 and the tabulated values given above permit the calculation of z as the numerical function of ω shown below.

We now have to relate f with ω . From Fig. 4.04,

$$r = a \sec \omega$$

and the fraction f of D remaining is given by

$$f = (2a - 2r)/D = 2a (1 - \sec \omega)/D$$

But $2a = D + d$ and $d = D/1.75$, so that

$$f = (11/7) (1 - \sec \omega) \quad 4,29$$

It is to be noted that $f = 0$ at the beginning of and is negative during this stage of the burning. The final value of f is $(11/7) (1 - \sec 42^\circ 25') = -0.557$. Equation 4,29 permits the calculation of f as a function of ω and the (z, f) relation is shown in tabular form below.

| ω | $V(xy\bar{z})/d^3$ | $V(pqr)/d^3$ | z | f |
|----------|--------------------|--------------|-------|--------|
| 0° | 37.97 | 208.5 | 0.851 | 0.000 |
| 5° | 35.49 | 201.3 | 0.856 | -0.006 |
| 10° | 28.99 | 185.5 | 0.870 | -0.024 |
| 15° | 20.29 | 159.3 | 0.891 | -0.055 |
| 20° | 11.02 | 127.4 | 0.916 | -0.101 |
| 25° | 3.32 | 92.36 | 0.942 | -0.162 |
| 30° | 0.00 | 55.84 | 0.966 | -0.243 |
| 32° 30' | — | 39.59 | 0.976 | -0.292 |
| 35° | — | 24.05 | 0.985 | -0.347 |
| 37° 30' | — | 11.54 | 0.993 | -0.409 |
| 40° | — | 2.99 | 0.998 | -0.480 |
| 42° 25' | — | 0.00 | 1.000 | -0.557 |

The complete (z, f) relation is given by the curve of Fig. 4.05.*

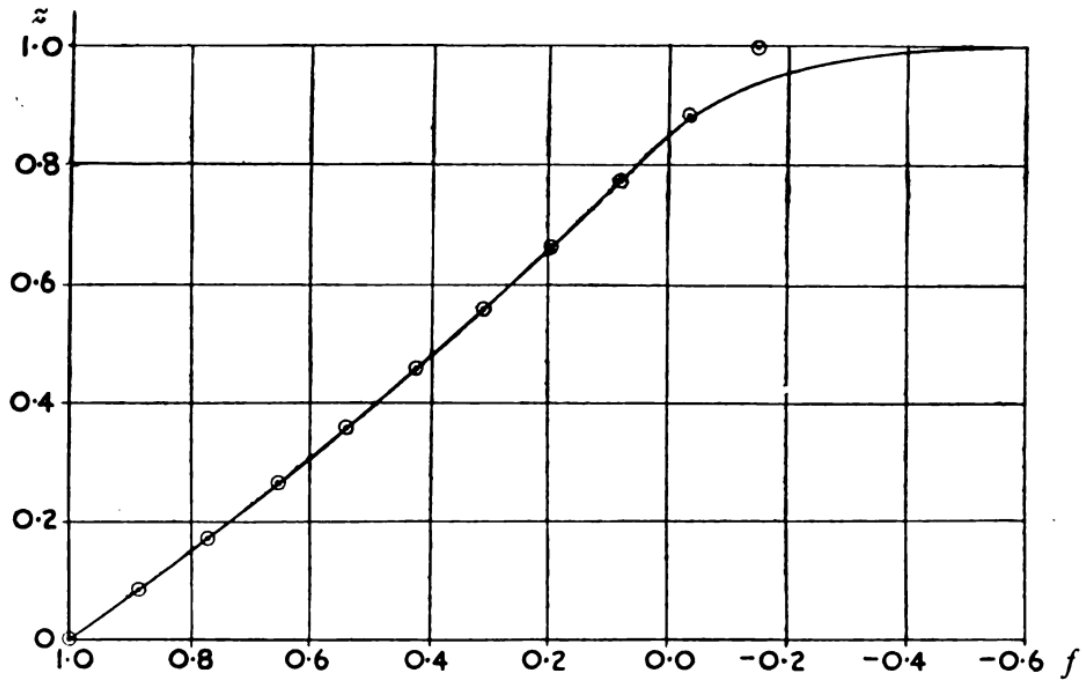

Fig. 4.05

* This curve is also given by Tschappat, *Text-Book of Ordnance and Gunnery*, Chapman and Hall Ltd. (1917).

4.09. Approximations to the form function for multitubular

We have seen that the form function up to the instant when the web is broken down is given by 4,16, viz.

$$z = (1 - f) (\cdot 850 - \cdot 117 f - \cdot 015 f^2)$$

and that during the second stage of burning the function is somewhat complicated. At the instant of breakdown of the web, 85 per cent. of the grain is consumed and therefore the above function holds during the greater part of burning. For convenience in the analytical solution of the ballistic equations, it is useful to enquire if a form function of the type

$$z = (1 - f) (1 + \theta f) \tag{4,30}$$

can be used to cover the whole burning. A form function of this type holds, with different numerical values of θ , for all the other shapes generally used in practice, and if we can derive an approximate function of this type for multitubular, we can use the quadratic form function 4,30 in the ballistic equations and develop one system of internal ballistics covering all shapes of propellant.

From 4,03,

$$z = [1 - (S/S_0)^2] (1 + \theta)^2/4\theta \tag{4,31}$$

and the best fit (least squares) for an expression of the type 4,31 with the (S, z) relation up to $z = 0.85$ is secured by taking $\theta = -0.1715$. With the true multitubular shapes, 85 per cent. of the grain is burnt when a thickness D of propellant has been consumed, while with a hypothetical shape possessing a form function of the type 4,30, 85 per cent. of the grain is burnt when a fraction f of the least thickness remaining is given by

$$\cdot 850 = (1 - f) (1 + \theta f)$$

which, with $\theta = -0.1715$, gives $f = 0.131$.

With the hypothetical shape, therefore, if D' is the least thickness to be burnt through for complete combustion, the thickness burnt through when 85 per cent. of the grain has been consumed is $0.869D'$; equating this to the actual web size D , we have

$$D' = 1.15D$$

Hence, an approximation is secured by using a form function

$$z = (1 - f) (1 - 0.172 f) \tag{4,32}$$

and using $1.15D$ instead of D in the ballistic equations. For comparison with the true form function of Fig. 4.05, this is equivalent to plotting the (z, f) relation from

$$z = (1 - f') (1 - 0.172 f') \tag{4,33}$$

where

$$1.15 (1 - f') = 1 - f$$

Values calculated from 4,33 are shown in Fig. 4.05 as circles.

Experiment has shown that some propellants made in this shape appear to burn with a surface area which decreases slightly in the early stages and increases slightly later. In such cases it is best to take $\theta = 0$ and this has the advantage of greatly simplifying the solution of the ballistic equations.

4.10. Summary

For shapes in general use, the form function can be written

$$z = (1 - f)(1 + \theta f) \quad 4.01$$

the various values of the form coefficient θ for the different shapes being shown in the table below. The table also shows the geometrical quantities which represent the least thickness to be burnt through for complete combustion of the grain, these quantities generally being referred to as the "size" of the propellant.

THEORETICAL VALUES OF THE FORM COEFFICIENT

| Shape of grain | "Size" D | Form Coefficient | Remarks |
|-------------------|--------------------------|------------------|---|
| Long cord | Diameter | 1 | |
| Long tube | Wall thickness | 0 | |
| Long slotted tube | Wall thickness | D^2/Ω | Ω = cross sectional area of tube |
| Multitube | $1.15 \times \text{web}$ | -0.172 | |
| Ribbon | Thickness | $1/\mu$ | μD = width of ribbon |
| Square flake | Thickness | $2/\mu$ | μD = side of square |

It must be remembered that the values of θ given in this table are based on the assumptions of simultaneous ignition of the whole grain surface and that burning takes place strictly in accordance with Piobert's law. Except for the tubular shapes these values of θ are generally found to be satisfactory in practice.

Ignition of the interior surface of long tubes seems to be delayed until the gas pressure reaches some 2 to 3 tons/sq.in. The inner surface then seems to burn at a high rate due probably to the extra transfer of heat by moving gases whose velocity is small at the centre and large at both ends of the tube. The holes thus burn faster at the ends of the tube and become bell-mouthed giving a greater rate of burning, but this effect seems to die away as the hole is enlarged. At a later stage, the internal surface in the bell-mouthed ends expands to meet the contracted external surface while there is still an appreciable annular thickness in the middle of the stick. When this occurs the stick rapidly shortens in length and so decreases in surface area. This shape therefore presents an effectively decreasing burning surface rather than a constant one and a form coefficient as high as 0.4 has been found necessary to explain some experimental results. There is some evidence (admittedly somewhat scanty) that θ varies as the length of the tube and its rate of burning and inversely as the size of the central hole.

Similar considerations apply to multitubular, although the comparatively short length of the grains should give a form coefficient closer to the theoretical value than is the case with long tubes. $\theta = 0$ has been suggested as a suitable value and this choice of θ has the advantage of rendering the solution of the ballistic equations comparatively simple.

Slotted tube burns closely in accordance with Piobert's law and the theoretical value of θ is usually adopted.

4.11. Variation of burning surface as burning proceeds

The general (S, z) relation corresponding to the quadratic form function $z = (1-f)(1+\theta f)$ is given by 4.03

$$z = [1 - (S/S_0)^2] (1 + \theta)^2 / 4\theta$$

The variation of S/S_0 with z for the various theoretical values of θ given in the table is plotted in Fig. 4.06, the values of λ , etc., being taken from the dimensions of typical propellants in Service use.

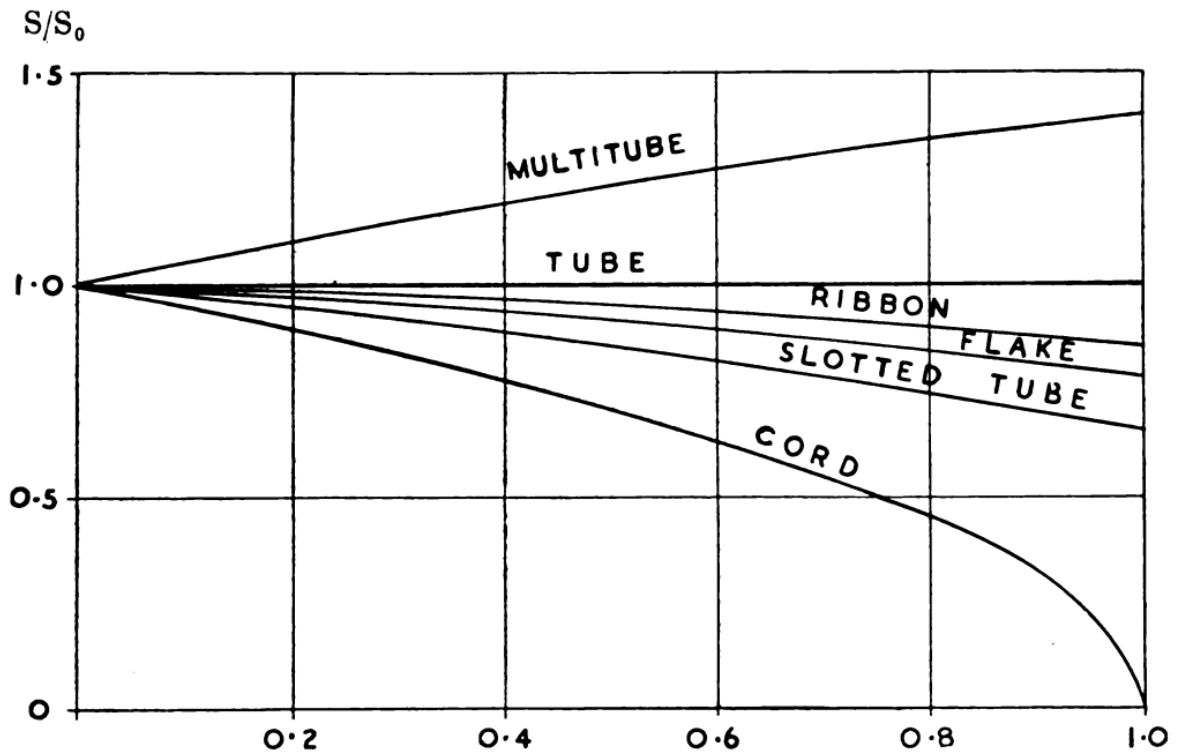

Fig. 4.06

CHAPTER V

COMBUSTION AT CONSTANT VOLUME

5.01. For the experimental determination of the ballistic properties of propellants a *closed vessel* is used ; this is a vessel in which propellants can be burned under constant-volume conditions. It is of robust construction, capable of withstanding the high pressures resulting from such experiments. Facilities are provided for inserting and igniting the charge, recording the pressure developed against a time scale and releasing the gases at the end of each experiment.

A full description of such a vessel and of the methods used for measuring pressure is given in Chapter XIII. In the present chapter we shall consider the analysis of the experimental results obtained from closed-vessel firings.

Measurements are made in a closed vessel instead of in a gun in order to avoid the complications due to the dynamics of the projectile and charge and the inevitable errors arising therefrom.

5.02. Objects of closed-vessel experiments

The main objects of closed-vessel experiments are :—

- (1) To verify the values of the force constant F and co-volume b of the propellant as calculated by the method of Chapter II.
- (2) To determine the rate of burning of the propellant.
- (3) To verify the more doubtful values of the form coefficient θ as calculated by the methods of Chapter IV.

With regard to (1), since F is sensitive to slight variations in propellant composition, particularly in the moisture content, the experimental values of F should be more reliable than the calculated values. The co-volume, on the other hand, is not sensitive to small changes in composition and can only be derived experimentally by a difference process ; the calculated values are therefore more reliable.

With regard to (2), it will be appreciated from Chapter III that the theory of propellant burning has not yet reached the stage when a thoroughly reliable law can be established on theoretical grounds alone. An experimental law for each propellant must therefore be determined and for this reason rate-of-burning experiments are the most important class of experiments performed in the closed vessel.

With regard to (3), the experimental determination of θ is desirable in the case of tubular and multi-tubular shapes, which do not always burn strictly in accordance with Piobert's law.

The closed vessel is also used to check variations in performance of Service propellants and to test experimental compositions. The former involves a simple comparison with a standard lot while the latter is an aid in the development of new types of propellant for specific purposes.

5.03. Experimental determination of the force constant and the co-volume

The equation of state of the propellant gases is (equation 2,15)

$$p(V - b) = TF/T_0$$

In the closed vessel, if there is no loss of energy or heat, this reduces to

$$p(V - b) = F \tag{5.01}$$

which is the law of Noble and Abel.

To determine F and b all that is required is a series of corresponding values of p and V . These are obtained by firing a number of charges of different weights and recording the maximum pressures. Since V is the volume per unit mass of gas, its value when the charge is completely burnt is K/C where K is the capacity of the vessel and C is the charge weight ; this value corresponds to the maximum pressure obtained. V is then plotted against $1/p$ and the best straight line is drawn through the points. The slope of the line gives F and the intersection on the V axis gives b . Alternatively, the theoretical value of b is used and F is calculated direct from 5,01, the results being averaged for a series of firings.

Unfortunately, the ideal of no heat and energy losses cannot be realised in practice and corrections have to be applied to allow for these losses. These will now be considered.

The maximum pressure in a closed vessel is a little less than that which would be realised under ideal conditions for two reasons. In the first place the vessel expands elastically and so there is a small adiabatic expansion of the gases causing a small pressure drop. This volume expansion is mainly due to stretching of the steel but there is also a contribution due to the bulk compression of the vaseline and luting packing used round the pressure gauge and firing pins. The total volume expansion may be readily calculated and is usually under 1 per cent. of the initial volume. It is, of course, proportional to the pressure, so that the energy loss and so the consequent fall in pressure is proportional to the square of that pressure at any instant ; thus

$$- dp/p = \gamma dK/K = \gamma \sigma p$$

so that

$$- dp = \gamma \sigma p^2 \tag{5,02}$$

where $1/\sigma$ is the elastic constant of the vessel, being the theoretical pressure required to double its volume.

The other source of energy loss is due to heat transfer to the vessel walls by radiation, convection and conduction. There is a small amount of radiation from the hot gases which will give a heat loss almost proportional to the time of burning and therefore to the size of a given propellant.* There is also a very intense radiation, due to chemi-luminescence, coming from the reaction zone, the amount of radiation being nearly proportional to the mass rate of burning, but this radiation will only reach the walls in the early stages of burning when the hot gases are not dense enough to be opaque.

Heat transfer by convection to unit area of wall surface will proceed at a rate nearly proportional to the product of gas density and velocity, since the wall surface remains at a much lower temperature than the hot gases throughout the burning period. The gas velocity at any point will increase in proportion to the mass rate of burning divided by the gas density, and the gas density is nearly proportional to the mass burnt. We find, therefore, when we integrate over the whole burning time, that the total convective heat loss should increase nearly in proportion to the mass burnt and be independent of the time of burning. It should also increase nearly in proportion to the absolute gas temperature, because the wall surface temperature remains quite low. Since the specific heat per unit mass of gas is found to be very nearly the same for all the usual propellant compositions, we see that convective heat loss should reduce the final pressure by a percentage which is constant for all propellants and sizes and for all charge weights but which increases in proportion to the ratio of wall surface to capacity.

* See Section 5.05.

For slow-burning propellants, the gas velocities will be very small and their components tangential to the vessel walls smaller still. In such a case we should expect heat losses by simple conduction, at a constant rate independent of gas density.

There is also a small pressure drop due to the fact that the gas which fills the channel leading to the release valve is cooled immediately to near room temperature so that the effective volume of this channel is nearly ten times as great as its actual volume. This volume is very small however and the consequent correction much less than 1 per cent. It is independent of the time of burning of the propellant.

To sum up, we should expect the total heat loss during the burning of a given charge weight of a given propellant to consist of two main terms, one being independent of the time of burning and the other being nearly proportional to it, or to the propellant size D .

Some early experiments were performed by Duncan and Craig* to determine the correction to pressure for heat and energy losses. They used a special vessel in which the capacity and ratio of surface area to capacity could be varied. They fired charges of four different sizes of cord at the same loading density in four different capacities. Plotting pressure against size for each capacity yielded four straight lines from which pressures for zero size, i.e., zero time of burning could be deduced by continuing the lines back to the pressure axis. These zero-time pressures were then plotted against the ratio surface/capacity and another straight line resulted, from which they deduced the uncooled pressure.

Later experiments of a similar nature, but with more accurate means of measuring, yielded similar results. The figures normally used to correct observed maximum pressures both for heat loss and vessel expansion are :—

| <i>Propellant</i> | <i>Percentage correction</i> |
|-------------------|------------------------------|
| N or NFQ | $3.7 + 15D$ |
| NQ or NQF | $2.5 + 15D$ |
| WM or SC | $0.9 + 15D$ |
| HW or HSC | $0.9 + 15D$ |

where D is the size in inches and the correction is additive.

The fact that the heat loss does not increase in direct proportion to the time of burning was shown experimentally by Crow and Grimshaw.† These authors suggested that the total heat loss increased in proportion to the square root of the total time of burning, but their results could be fitted equally well by a linear relation of the form given above.

5.04. Combustion phenomena in a closed vessel

When a propellant charge is burnt in a closed vessel the conditions are usually so chosen that the energy lost by the gases during combustion is very small and, as we have seen, can be allowed for in a simple manner. In other words, the process is an adiabatic one, and all the heat liberated by the chemical reaction is used in heating the gases. Assuming uniformity of temperature as well as pressure throughout the gases, this temperature and pressure can be calculated from the mass, composition, heat of formation and initial temperature of the propellant charge, and the volume of the closed vessel, using thermochemical data and methods as explained in Chapter II.

Actually there is, at first, considerable lack of uniformity of temperature. If we consider the combustion of any given small quantity of propellant during the reaction, the gases evolved will be formed under practically constant pressure, and will make room for themselves by compressing the gases previously burnt. Each element of gas will therefore be formed under constant-pressure conditions, and its initial temperature will correspond to combustion under

* Research Department Report No. 15 (1911).

† A. D. Crow and W. E. Grimshaw. *The equation of state of propellant gases*, Phil. Trans. A. 230 (1932) p. 39.

those conditions. Subsequently the element of gas will be compressed adiabatically to make room for the gases formed in the later stages of the combustion. Different elements of gas will start at almost the same temperature, but will subsequently attain temperatures given by

$$T/T_2 = (p_2/p)^{1-1/\gamma} \quad 5,03$$

where p_2 is the final pressure and p the pressure under which a given element was formed. Since p is different for every element so will T be. In fact the first element, which was formed under a very low pressure, will attain a very high temperature indeed, while the last element to be formed will suffer no adiabatic compression at all and will remain at temperature T_2 .

Of course, both during and after combustion heat transfer and gas mixing will tend to equalise the temperature throughout the closed vessel to T_0 , the value calculated from thermochemical data for a reaction under constant-volume conditions. This temperature equalisation continues for a short time after combustion is complete and in the case of hot propellants this gives an exaggerated rate of pressure fall for a very short time, so giving a sharp maximum on the pressure-time curve. The maximum is less sharply defined for cool propellants. This may be due to the fact that the specific heats of the gases increase with increasing temperature, so that if there were no heat losses the mean temperature and hence the pressure would rise during the equalisation process. This effect must also operate in the case of hot propellants but is probably over-compensated by high radiation losses from the hot regions.

The variation of temperature throughout the closed vessel implies that the gases near the vessel walls in the early stages of combustion will have a very high temperature and so lose heat to the walls very rapidly. We must therefore expect the rate of heat loss to vary considerably during the combustion period. Furthermore it would be impossible to attach any precise meaning to measurements of gas temperature during burning by optical or other physical methods.

A second and more important conclusion to be drawn from this discussion of the combustion phenomena is that no matter how the pressure is changing, any given small element of gas is formed under practically constant pressure, so that the temperature of the gases near the propellant surface, and hence, the rate of burning, will be independent of the mean temperature throughout the whole vessel. For a given propellant at a given initial temperature therefore, the rate of burning will be a function of the gas pressure only and will be the same function in the gun as in the closed vessel. This conclusion has been verified experimentally by Muraour* who varied the mean gas temperature in a closed vessel by introducing extra cooling surfaces.

Using the notation of Chapter IV, the reduction of the dimension D of the grain at any moment is $(1 - f) D$ and the rate of burning is therefore $- Ddf/dt$. This, therefore, is a function of the pressure and is usually expressed in the form

$$- Ddf/dt = \beta p^\alpha \quad 5,04$$

where α and β are constants for a given propellant composition ; β is called the *rate-of-burning coefficient* and α , the *rate-of-burning index* or *pressure index*. We have seen in Chapter III that, for the high pressures with which we are concerned, α should be nearly unity.

* H. Muraour, Zeit. fur phys. Chem. A., p. 163, 1928.

Before considering methods of deducing α and β experimentally it will be convenient to consider some properties of the theoretical pressure-time curve obtained from burning at constant volume.

5.05. The theoretical pressure-time curve

If z is the fraction of charge weight burnt at time t , the volume occupied by the gases at that time is $K - (1 - z) C/\delta$ where δ is the density of the solid propellant. The value of V in equation 5.01 is therefore

$$[K - (1 - z) C/\delta]/Cz$$

and the equation takes the form

$$FCz = p [K - bC + (1 - z) C (b - 1/\delta)] \quad 5.05$$

From 4.01,

$$z = (1 - f) (1 + \theta f) \quad 5.06$$

and the differential equation of the pressure-time curve is obtained by eliminating f and z between 5.04, 5.05 and 5.06. The result can be expressed in the form:—

$$\frac{D}{\beta p_2^\alpha} \frac{d\psi}{dt} = \frac{(1 + n\psi)^2}{1 + n} \left[(1 - \theta)^2 + \frac{4\theta(1 - \psi)}{1 + n\psi} \right]^\dagger \psi^\alpha \quad 5.07$$

where $p_2 = FC/(K - bC)$ and is the final or maximum pressure,

$$\psi = p/p_2, \quad n = C(b - 1/\delta)/(K - bC)$$

Clearly, $\beta p_2^\alpha t/D$ is a function of θ , α , n and ψ . Hence, for the same propellant and shape, and the same loading density C/K , p is the same function of t/D . The effect of varying D , all other loading conditions being the same, is therefore to alter the time in the same ratio. In particular, the total time of burning is proportional to D . This result was assumed in Section 5.03.

Since the loading density C/K is generally low in closed-vessel experiments and $(b - 1/\delta)$ is also reasonably small, the quantity n is also small. Hence, for the same propellant and shape, $\beta p_2^\alpha t/D$ is nearly the same function of p/p_2 for all loading densities.

Similarly, for propellants having the same index α and the same shape, $\beta p_2^\alpha t/D$ is nearly the same function of p/p_2 for all loading densities.

The slope of the curve is always positive, except when $\theta = 1$ and $\psi = 1$, when it is zero. A true maximum pressure is therefore realised only with cord; with all other shapes the pressure is still rising at the end of combustion and the slope of the pressure-time curve at this point is $(1 + n)(1 - \theta)\beta p_2^{1+\alpha}/D$.

Some typical pressure-time curves are illustrated in Fig. 5.01. These are all for the same charge weight and pressure index (unity) with different values of θ .

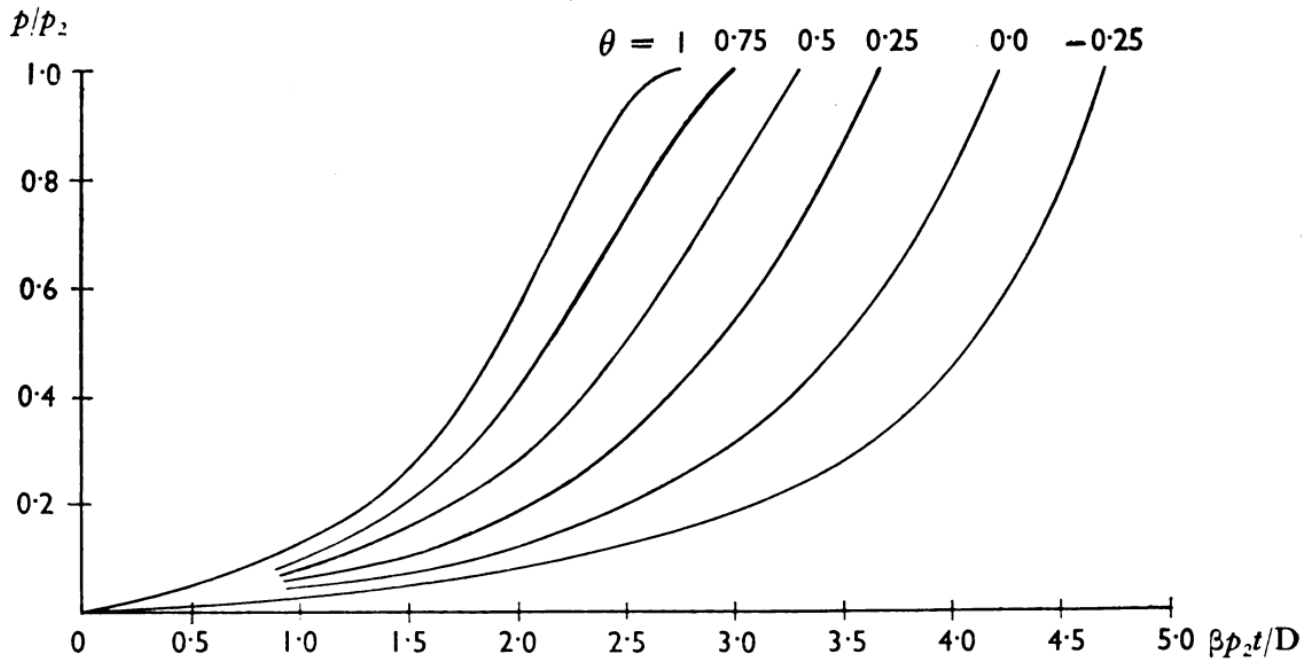

Fig. 5.01

5.06. Determination of rate-of-burning constants

To determine the constants α and β in equation 5,04 we require corresponding values of df/dt and p . The pressure-time record gives us a continuous record of the pressure, but unfortunately we have no corresponding record of the size of the propellant grain during burning. A technique has been developed by which the burning can be interrupted at selected intervals of time, so that the grains can be subsequently measured, but reliable records are not yet available. We must therefore rely on calculation based on the known properties of the propellant.

Combining equations 2,15 and 5,05,

$$FCzT/T_0 = p [K - bC + (1 - z) C (b - 1/\delta)] \quad 5,08$$

and, if the temperature and pressure when $z = 1$ are T_2 and p_2 ,

$$FCT_2/T_0 = p_2 [K - bC]$$

Hence

$$z = (1 + n) p / (p_2' + np) \quad 5,09$$

where

$$p_2' = T p_2 / T_2 = FCT / T_0 (K - bC)$$

and, as before,

$$n = C (b - 1/\delta) / (K - bC)$$

If, therefore, we know T/T_0 at each stage, we can calculate z from the observed pressure at each instant.

Since
$$z = (1 - f)(1 + \theta f)$$

it follows, by differentiating and solving for f , that

$$-df/dt = [(1 + \theta)^2 - 4\theta z]^{-1} dz/dt \quad 5,10$$

Hence by numerical differentiation of the calculated z , t relation corresponding values of df/dt and p can be deduced. Thence α and β can be obtained by plotting on logarithmic paper and putting the best straight line through the points.

The numerical differentiating process is somewhat inaccurate and a technique has been developed whereby the pressure is differentiated electrically, yielding a record which gives dp/dt against p .^{*} This may be used to determine df/dt directly.

Differentiating 5,09 yields

$$\frac{dz}{dt} = \frac{(1+n)p_2' dp}{(p_2' + np)^2 dt}$$

while 5,10 may be written

$$-df/dt = \left[(1 + \theta)^2 - \frac{4\theta(1+n)p}{p_2' + np} \right]^{-1} \frac{dz}{dt}$$

Thus, df/dt can be calculated directly from the dp/dt , p record.

We will now consider the problem of determining T/T_0 .

5.07. Ignition of the charge in a closed vessel is started by heating a fine fuze wire which ignites a gas mixture, usually consisting of ethylene, oxygen and air. For picrite propellants which are difficult to ignite a small amount of fine nitrocellulose powder, which is readily ignited by the ethylene flame, is used to provide a stronger ignition flame. This flame cools rapidly, warming the propellant surface as it does so and the propellant then starts to burn. This delay in ignition of the main charge, of the order of one or two hundredths of a second, gives time for pressure pulses in the igniter gas to die down and also reduces the difference in ignition time between different parts of the propellant surface. It is, of course, always assumed that all parts of the propellant surface start to burn simultaneously.

At the commencement of burning, therefore, the vessel is filled by almost cold gas of similar composition to the propellant gas, and of mass about 1 per cent. of that of the propellant charge. If there were no heat losses during burning the mean temperature throughout the vessel would rise asymptotically toward T_0 , increasing from about $.97 T_0$ to $.99 T_0$, i.e., by about 2 per cent. in the period from 30 per cent. burnt to 100 per cent. burnt, which is the period in which we are most interested.

If all the heat loss during burning occurred at a rate proportional to the mass rate of burning then the effect would be the same as if T_0 were lowered by a fixed amount. Some of the heat loss, however, appears to proceed at a nearly constant rate and so to produce a greater effect in the early stages. The nett effect is therefore to produce a small fall in temperature which is least when the mass rate of burning is greatest. We should therefore expect the mean gas temperature to rise slightly during the period from 20 per cent. burnt to all-burnt for propellants with nearly-constant burning surface, but to reach a maximum between 70 per cent. and 90 per cent. burnt and then start to fall in the case of cord propellants.

* See Section 13.09.

Reliable measurements of the heat transferred to the vessel walls during the combustion period have never been made, although suitable techniques are now available. Until such measurements are made the best that can be done is to assume that the rate of heat loss is proportional to the mass rate of burning, i.e., we can assume a constant mean gas temperature throughout the burning period, except that we can allow for the cooling effect due to the igniter gas.

Just before ignition of the charge the igniter gas is at a temperature very little above room temperature. If its mean molecular specific heat over the range from room temperature to T_0 were equal to that of the propellant gas over a range near T_0 then on mixing the cold igniter gas with hot propellant gas the increase in pressure due to the former would exactly balance the decrease in pressure due to the latter. Throughout the burning, therefore, the effect of the presence of the igniter gas is to increase the total pressure by a constant amount, approximately equal to the pressure produced by the cold igniter gas alone.

For cord propellants the charge is not quite completely burnt at maximum pressure, but all-burnt occurs a little later and at a slightly lower pressure. If we assume that the charge is all burnt at maximum pressure, as we usually do, then the mean gas temperature calculated for that point is a little less than the true value but a little greater than the value for all-burnt. It gives us quite a reasonable estimate of the mean temperature throughout the important part of the burning period, from say 30 per cent. to 90 per cent. burnt. We cannot use the early part of the pressure-time curve because a rapid rise of temperature is taking place and we cannot use the part of the curve near maximum since here the shape of the curve is determined by small differences between the rate of rise of pressure due to continued burning and the rate of fall of pressure due to cooling.

For constant burning surface propellants much the same limitations hold except that we can go a little nearer to maximum pressure. The top of the curve always departs from the expected shape because some sticks of propellant finish burning a very short time before others.

We conclude that if we use only that part of the curve representing from 30 per cent. to 90 per cent. of the charge burnt we can assume $T = T_2$ and take p_2' as the observed maximum pressure.

5.08. A further correction may be required to allow for the effect of heat losses on the deduced rate of burning. Heat losses which occur at a rate proportional to the mass rate of burning do not affect the shape of the pressure time curve and so do not affect measurements of the rate of burning, but we have also to consider other rates of heat loss. In the case of propellants with nearly-constant burning surface the end of burning always coincides with maximum pressure. In consequence the total time of burning, and hence the mean rate of burning, can be measured without any error being introduced by the heat losses. It therefore follows that for such propellants the effect of cooling losses, which follow any reasonable law of variation with time, on the rate of burning constant must be very small indeed and of unknown sign so that we must neglect it.

In the case of cord propellants all-burnt occurs a short time after the maximum pressure so that there must be some part of the heat loss proceeding at a rate independent of the mass rate of burning of the propellant. Measurements after all-burnt show that the pressure falls almost exponentially with time, i.e., that the rate of heat loss is nearly proportional to the gas temperature. During the burning, therefore, since the mean gas temperature is almost stationary, we should expect part of the heat loss to proceed at a constant rate. If this constant rate is sufficient to reduce the maximum pressure by 1 per cent. then it can be shown that it will increase the measured rate-of-burning constant by about 0.5 per cent. In closed-vessel work it is customary to reduce the measured rate of burning by a percentage equal

to half the percentage increase that is applied to the maximum pressure as indicated in Section 5.03.

5.09. Hunt-Hinds method of analysis

We have already mentioned the uncertainty of the theoretical value of θ for some shapes of grain ; it is therefore desirable to use a shape for which the theoretical value of θ is reliable when experimental determinations of rate of burning are undertaken. The most reliable shape for this purpose is cord, for which $\theta = 1$.

We have also observed that the index α is generally near unity. We shall see later that a complete solution of the gun problem can be developed when $\alpha = 1$. It is therefore desirable to have a method of analysing the pressure-time curve which yields the best value of β over a given range of pressures when the index is assumed to be unity. Such a method, which also avoids numerical differentiation, was developed by Hunt and Hinds.*

The method consists in calculating directly, from the pressure-time curve, the function

$$y = \ln(1 + f) - \ln(1 - f) - 2Bf \quad 5,11$$

where $B = C(b - 1/\delta)/(K - C/\delta)$ and f is calculated from the relations,

$$f^2 = 1 - z \quad 5,12$$

and
$$\frac{1}{z} = \frac{FC}{p(K - C/\delta)} + B \quad 5,13$$

The former is derived from the form function for cord and the latter, from equation 5,05.

We have, at once,

$$\frac{dy}{dt} = 2 \left(\frac{1}{z} - B \right) \frac{df}{dt} = - \frac{2FC \beta}{(K - C/\delta) D}$$

when $\alpha = 1$.

If, therefore, y is plotted against t , we should obtain a straight line, the slope of which is proportional to β . In practice β is obtained by putting the best straight line through the points for a given range of pressures.

Since the method is based on equation 5,05, which is only true when there are no energy and heat losses, it is necessary to apply corrections for these losses. For this purpose the method, developed by Crow and Grimshaw,† of allowing for losses up to the instant of maximum pressure has been extended to allow for losses up to any time t during the explosion.

The mean temperature T of the gases at time t is obtained from

$$Cs z (T_0 - T) = cp^2 S + (T - T_i) aS\sqrt{t},$$

which equates the loss of heat up to time t to the energy (in heat units) lost in expanding the vessel and the heat lost to the vessel. In this equation, s is the mean specific heat of the gases, S is the area and T_i the initial temperature of the internal surface of the vessel, and a and c are constants of the vessel.

The actual equation of state at any moment is 5,08 and eliminating f and z between this equation and 5,04 and 5,12 leads to a relation between pressure and time of the form

$$\frac{pT_0}{FT} = \varphi \left[\frac{F\beta}{D} \frac{\bar{T}(t' - t)}{T_0} \right]$$

* *The rate of burning of colloidal propellants.* Proc. R. Soc. A. Vol. 138, 1932.

† Crow and Grimshaw. *The equation of state of propellant gases*, Phil. Trans. A. Vol. 230 (1932) p. 50.

where t' is the time at all-burnt and \bar{T} is the average temperature over the time interval $t' - t$.
Under uncooled conditions,

$$\frac{p_0}{F} = \varphi \left[\frac{F\beta(t'_0 - t_0)}{D} \right]$$

where p_0 is the uncooled pressure corresponding to p and $t'_0 - t_0$ is the corresponding value of $t' - t$.

Hence

$$p_0 = T_0 p / T$$

when

$$t'_0 - t_0 = \bar{T} (t' - t) / T_0$$

and these give the pressure and corresponding time when there are no losses.

The function y is calculated from the corrected pressure and is plotted against the corrected time.

5.10. Some numerical results

The following table gives some measured values of rates of burning. Corrections for vessel expansion and cooling have been applied but these propellants were not fired in the standard vessel and so the results are less accurate. In particular the values of α are not very accurate but the values of β_1 , the constant in the equivalent linear law deduced for a maximum pressure of 22 tons/sq.in. should be quite good.* For values of α within 0.2 of unity a good approximation for β_1 is

$$\beta_1 = \beta - \beta (10\alpha + 9) (1 - \alpha) / 8.$$

| Propellant | Lot No. | δ | α | β | β_1 |
|-----------------|-----------------------------|----------|----------|---------|-----------|
| MD 8 | W.A.12825 | .0574 | 1.00 | 1.38 | 1.38 |
| MD 8 | B.1631 | .0574 | .93 | 1.54 | 1.29 |
| MD 11 | W.A.9024 | .0574 | 1.02 | 1.25 | 1.32 |
| W 057 | W.A.C.116 | .0581 | .90 | 1.49 | 1.14 |
| SC 048 | R.N.C.390 | .0567 | .92 | 1.21 | .98 |
| NQF 045 | Batch 823 | .0607 | .79 | 1.34 | .77 |
| NFQ 042 | W.A.12860 | .0592 | .76 | 1.14 | .60 |
| NFQ 042 | Batch 808 | .0592 | .74 | 1.17 | .59 |
| N 022 to 096 | { A.R.D.228 A, B, C, & D | .0592 | .82 | 1.02 | .63 |

δ is in lb./cu.in. β gives rate of burning in ins./sec. when p is expressed in tons/sq. in.

* These values are taken from H. H. M. Pike, *Ballistic data for some British propellants*, A.C.2619/IB.122.

In addition the rates of burning of SC and a semi-solventless NFQ composition have been measured by an alternative method in which the pressure is kept constant and the time required to burn through a known thickness is measured.* The results so obtained are free from errors arising from uncertainties in heat loss or in the equation of state but the method is too elaborate for routine use. The rates of burning over the range 3 tons/sq.in. to 14 tons/sq.in. were best fitted by the values

$$\alpha = 0.960 \quad \beta = 1.070 \quad \text{for SC}$$

and $\alpha = 0.818 \quad \beta = 1.020 \quad \text{for NFQ}$

The result for NFQ agrees almost exactly with the figures for N given in the last row of the table. These latter figures are more accurate than any other figures given in the table since firings were carried out with three different charge weights of four different sizes of cord, all pressed from the same paste and dried as nearly as possible to the same content of volatile matter. For SC the more accurate method gives a slightly higher index but a value of β_1 one per cent. lower.

The small difference between the two lots of NFQ is due to the fact that the former contained no sodium cryolite. The very low values of α observed with those two propellants are not thought to be real; these were early samples of picrite propellant and there may have been a relatively large concentration of the nitroguanidine crystals near the central axes of the cords.

Closed-vessel firings have also been carried out for different initial temperatures of the propellant over the range from 35°F. to 120°F. in order to find the effect of temperature variation on the rate of burning. In the following table are given some measured values of the percentage increase in rate of burning for 10°F. rise in propellant temperature.†

| Propellant | Percentage increase in β_1 per 10° F. | Temp. range °F. | Percentage increase in F per 10° F. |
|------------|---|-----------------|-------------------------------------|
| HSC | 2.0 | 35—120 | 0.13 |
| SC | 2.0 | do. | 0.17 |
| WM | 2.2 | 35— 80 | 0.15 |
| A | 1.9 | 35—120 | 0.18 |
| N & NFQ | 1.0 (variable) | do. | 0.22 |

In all cases these figures are for propellants in cord form.

An addition of 1 per cent. by weight of either water or solvent to a propellant decreases the rate of burning by about 15 per cent. and the force by about 2 per cent. Since British propellants of the non-picrite type will absorb about 1 per cent. of moisture in an atmosphere of 80 to 90 per cent. relative humidity the treatment of the propellant before firing is of considerable importance. When closed-vessel firings are required in connection with gun firings an extra round is made up in the magazine and treated in exactly the same way as the

* H. H. M. Pike and H. Green. *Development of a new technique for closed-vessel determination of rates of burning and applications to both solid and liquid propellants.* A.R.E. Report 5/48.

† H. H. M. Pike. *The effect of initial temperature on the ballistic properties of propellants,* A.R.D. Ballistics Report No. 34/44. See also H. A. Flint, A.R.D. Ballistics Report No. 12/45.

other rounds. At the time of the gun firing this round is broken down and a sample taken which is immediately placed in an airtight glass bottle, where it is kept until it can be fired in the closed vessel.

Variation of manufacturing procedure can also have an appreciable effect on β_1 , presumably associated with corresponding variation in the structure of the colloid. Thus the temperature of the incorporations and the composition of the solvent must be standardised and maintained within prescribed limits. The particle-size of the picrite ingredient is a further factor influencing β_1 in picrite propellants. The magnitudes of these effects have however not yet been precisely evaluated.

Representative values of the rates-of-burning indices and coefficients are given in Table 5.01 for the propellants in common use. These values are intended for use in routine calculations, but it must be stressed that they are only representative and that in individual samples and lots appreciable variations from these values may occur. The table also gives percentage variations in F and β_1 for 10°F . variation in initial (or charge) temperature ; these also are representative.

5.11. The burning of tubular and multi-tubular shapes

When measurements of the temperature coefficient of rate of burning were first made it was found that the shape of some propellants had a marked effect both on their rate of burning and on its variation with temperature. The variation in rate of burning was found to be due to a very high rate of burning inside the holes of tube or multitube. This phenomenon is well known in the case of rocket propellants, where it had been found that the rate of burning is increased if the propellant gases have a high velocity tangential to that surface. An explanation of the phenomenon was given in Section 3.12.

For sufficiently low velocities the rate of burning is independent of gas flow, but if the gas velocity exceeds a certain critical value the rate of burning starts to increase. Experiments on SC and similar propellants at rocket pressures show that the rate of burning can then be expressed very nearly by a relation of the form

$$-Ddf/dt = \beta p^\alpha [1 + A(u - u_0)] \quad 5,14$$

where u is the mean gas velocity tangential to the surface, A is a constant and u_0 the critical velocity.* Experiments confirm the expectation mentioned in Section 3.12 that u_0 increases and A diminishes for hotter propellants, where the burning zone is thinner. They also show that A varies very little with variations in initial temperature of the propellant.

In guns, propellants much cooler than SC may be used and since the reaction zone is then much thicker we should expect u_0 to be very small and A very large, and probably that we should have to use a more complicated function of u in place of the simple linear relationship of equation 5,14. Direct measurements of the laws of erosive burning of gun propellants have not yet been carried out, but in many cases the erosive rate of burning appears to be very much greater than for SC as judged by the differences in burning rate between cord and tube of the same composition.

The erosive burning of tubular (or multi-tubular) propellant increases the apparent burning surface in the early stages of burning. Since the gas velocity is highest at the ends of the holes these burn away faster and so the holes become nearly conical in shape at the ends. The gas velocity then dies down and so the rate of burning falls to little more than the value one would expect if no erosion occurred. Owing to the coning out of the holes, however, the web is soon

* S. F. Boys and D. M. Clemmow, *A determination of the law of erosion for SUK propellant*, A.R.D. Ballistics Report No. 33/45.

burnt through at the ends of the tube and then the tube shortens in length very rapidly, decreasing the burning surface. For tubular propellant therefore, closed-vessel experiments show that the burning surface is in effect not constant but decreasing. For W/T 109-038, cut in 5-inch or 10-inch lengths, the rate of mass burning can be approximated fairly well by taking the same linear rate of burning as for cord propellant and the correct web size but $\theta = 0.15$ or 0.3 instead of zero. American NH propellant would have a negative value of θ of the order of -0.15 if burning proceeded by parallel layers but in fact the erosive burning is sufficient to give an effective value of θ very near zero.

Evidence of recent origin leads to the conclusion that the delayed ignition in the perforations of tube or multi-tube has an important effect on temperature coefficients. If the delay is increased by reducing the initial charge temperature, ignition in the perforation is completed at a later stage of burning, and therefore at a higher pressure, with a consequent increase in the amount of erosive burning, which effectively reduces the temperature coefficient.

The value of θ for tube and multitube is generally required in conjunction with the linear law of burning. It can, however, be deduced from the pressure-time records of closed-vessel experiments for the more general law of equation 5,04. The values of α and β having been determined from experiments with cord for a given propellant composition, a series of values of f can be calculated from the p, t record of a firing with the particular shape by direct integration, since

$$f = \frac{\beta}{D} \int_t^{t_2} p^\alpha dt$$

The corresponding values of z are calculated from 5,05 in the form

$$z = \frac{(1+n)p}{p_2 + np}$$

where

$$n = C(b - 1/\delta)/(K - bC)$$

From the series of corresponding values of z and f the best value of θ can be determined.

We conclude this Chapter with a short account of Charbonnier's form function and his method of deriving the appropriate burning constants from closed-vessel firings.

5.12. Charbonnier's form function

Charbonnier's method of treating the burning of propellants is independent of Piobert's law of burning by parallel layers. He deals with the rate of change of mass of the solid portion of the charge and postulates the law

$$dz/dt = Qp^\alpha \varphi(z) \tag{5,15}$$

where Q is a constant, called the *vivacity* or *quickness* of the propellant, and $\varphi(z)$ is Charbonnier's form function. If the propellant does burn in parallel layers, this function is the ratio of the burning surface at any moment to the original surface area of the propellant. Then, from 4,03,

$$\varphi(z) = [1 - 4\theta z/(1 + \theta)^2]^{\frac{1}{2}}$$

and therefore, from 5,04 and 5,10,

$$Q = (1 + \theta) \beta/D \tag{5,16}$$

Whatever the mode of burning, it is generally assumed that $\varphi(z)$ depends on the shape alone, whereas Q depends on the composition, shape and size of the propellant. The value of $\varphi(z)$ when $z = 0$ is always chosen as unity.

Values of z are determined, as previously described, from the pressure-time curve, using equation 5,05 in the form

$$z = (1+n) p / (p_2 + np)$$

and the approximation is usually made that n is negligible, so that $z = p/p_2$.

With this approximation we have

$$dz/dt = Q p_2^\alpha z^\alpha \varphi(z).$$

Hence

$$p_2^\alpha (t_1 - t_0) = \frac{1}{Q} \int_{z_0}^{z_1} \frac{dz}{z^\alpha \varphi(z)} \quad 5,17$$

where $t_1 - t_0$ is the time interval between two selected values, z_0 and z_1 of z .

If, therefore, we have a series of firings with the same shape and size of the same powder, but at different loading densities, and the same values of z_0 and z_1 are selected to determine $(t_1 - t_0)$ from each record, the right-hand side of equation 5,17 remains unchanged, and α can be deduced from the final pressures and the corresponding time intervals. We have, in fact,

$$\alpha \log p_2 + \log (t_1 - t_0) = \alpha \log p_2' + \log (t_1' - t_0') = \dots$$

and by plotting p_2 and $(t_1 - t_0)$ on logarithmic paper, α can be determined.

In Charbonnier's (and Sugot's) method of gun calculation numerical values of the function

$$V(z) = \int_0^z \frac{dz}{\varphi(z)}$$

are required.

This function can be derived from the p, t curve by constructing the curve p^α, t and integrating. From 5,15 it is evident that

$$\int_0^t p^\alpha dt = \frac{1}{Q} \int_0^z \frac{dz}{\varphi(z)} = \frac{V(z)}{Q}$$

If this integral is now plotted against z , the slope of the curve at $z = 0$ has the value $1/Q$, since $dV(z)/dz = 1/\varphi(z)$ and this is unity at $z = 0$. Thus Q is obtained and therefore $V(z)$ as a numerical function of z .

In the method of gun calculation referred to, α is assumed to be unity; the function $V(z)$ is then obtained at once from the p, t curve by direct integration.

Charbonnier found that for French tubular powders, with $\alpha = 1$, the form function could be represented reasonably well by the expression

$$\varphi(z) = (1 - z)^{0.2}$$

CHAPTER VI

THE ENERGY EQUATION

6.01. In order to derive the energy equation of internal ballistics we consider the application of the principle of the conservation of energy to the reactions which occur in the gun. The source of energy lies in the chemical energy of the propellant. This energy is made available when the propellant is raised to the appropriate temperature, and is converted into a number of forms. The two most important forms are the heat energy of the gases and the external work done on the projectile during expansion. In addition, there are secondary forms such as the kinetic energy of the gases, the kinetic energy of the recoiling parts of the gun and various strain energies in the gun, projectile and driving band.

Of these secondary forms, some are small enough to be ignored with confidence, others, although not negligible, are small enough to be allowed for by approximate methods. Accordingly we consider in Sections 6.02—6.06 a first approximation to the energy equation, known as Résal's equation, involving only the principal energies. In Sections 6.07 *et seq.*, we consider means of extending this equation in order to allow for the more important of the secondary energy losses.

6.02. The conservation of energy

If the internal energy of the gases be denoted by U , the external work done on the projectile by W and the energy supplied by the burning propellant by Q , then we have, neglecting all secondary energy losses

$$Q = U + W \qquad 6.01$$

The three quantities must, of course, be measured in the same system of units.

We now replace these symbols by more specific variables.

6.03. The energy released by the propellant

The amount of energy released by the burning propellant may be conveniently calculated by considering the propellant to be burnt in an enclosed vessel. Suppose that unit mass of propellant is burnt; after burning we have unit mass of gas at an absolute temperature T_0 (say). This temperature is the adiabatic flame temperature and is a characteristic of the propellant. It is calculated by methods described in Chapter II. The energy of this gas is, of course, equal to the chemical energy of the propellant, so that if we can write down an expression for the heat energy of the gas in the closed vessel we shall be able to derive an expression for Q .

Let the specific heat at constant volume of the gases at any temperature T be σ_v heat units per unit mass (e.g. calories per gram.). Then the amount of energy in the gases in the closed vessel is given by

$$\int_0^{T_0} \sigma_v dT \text{ heat units.}$$

In this expression, the lower limit of integration is conveniently taken as 0° absolute, but any other fixed lower limit would be equally suitable as it is only changes of energy which will be considered and not absolute values.

Since this energy is derived from unit mass of propellant, we conclude that if from a total mass of propellant C a fraction z has been burnt at the instant under consideration, then the energy liberated is given by

$$Q = Cz \int_0^{T_0} \sigma_v dT \text{ heat units,}$$

or,
$$Q = JCz \int_0^{T_0} \sigma_v dT \text{ mechanical units} \quad 6,02$$

where J is Joule's Equivalent giving the number of mechanical units in one heat unit.

This equation requires a little more consideration, however. It involves the quantities T_0 and σ_v which depend to some extent on the pressure of the gases evolved from the propellant. This dependence arises because the equilibria reached by the dissociation products are affected by pressure. For example, the dissociation of hydrogen molecules into atomic hydrogen is enhanced at low pressures, and as the dissociation is accompanied by absorption of energy, it follows that T_0 will tend to drop at low pressures; this is most marked for the hotter propellants where dissociation occurs to a greater extent. Similarly σ_v depends on the constitution of the gaseous mixture and must also depend on pressure. A second effect is due to the fact that the gases are not quite perfect and there is a small decrease in the mean specific heat, so giving a further slight increase in T_0 with increasing pressure. However, these two effects are small over the range of pressures in which we are interested, and it is permissible to use a fixed value of T_0 for each propellant. Similarly it will be expected that, for a given propellant, σ_v will depend on the temperature only.

We can therefore conclude that equation 6,02 gives an adequate expression for the amount of energy supplied to the gun, in terms of quantities T_0 and σ_v which can be calculated in the manner described in Chapter II.

6.04. The internal energy of the gases in the gun

In the gun, owing to expansion and the performance of external work, the gas temperature is less than that reached in the closed vessel and we shall denote it by T . Consider then the internal energy of gas at temperature T , and of mass Cz . We can evaluate this by considering, as in Section 6.03, the amount of energy required to heat the gas from absolute zero to temperature T . Since it is the internal energy we require we shall clearly imagine the gas to be heated at constant volume since under this condition no external work is done. Hence the required internal energy of the gas is given by

$$U = JCz \int_0^T \sigma_v dT \quad 6,03$$

6.05. The external work done in expansion

If we introduce the following notation :—

A = area of bore including rifling grooves,

x = distance travelled by shot at instant under consideration,

p_t = pressure on base of shot at this instant,

then the external work done may be written

$$W = A \int_0^x p_t dx \quad 6,04$$

6.06. Development of Résal's equation

By inserting into 6,01 the expressions we have found for Q , U and W in 6,02, 6,03, and 6,04 we obtain

$$JCz \int_0^{T_0} \sigma_v dT = JCz \int_0^T \sigma_v dT + A \int_0^x p_r dx$$

which may be written

$$JCz \int_T^{T_0} \sigma_v dT = A \int_0^x p_r dx$$

Now although σ_v varies considerably over the temperature range 0 to T , its variation over the range T to T_0 is smaller and we can replace σ_v in the integral by a value $\bar{\sigma}_v$ which is a mean over the temperature range to be expected in the gun. We thus have

$$JCz \bar{\sigma}_v (T_0 - T) = A \int_0^x p_r dx$$

i.e.,
$$JCz \bar{\sigma}_v T_0 = JCz \bar{\sigma}_v T + A \int_0^x p_r dx \quad 6,05$$

We now eliminate T from this equation by means of the equation of state (Section 2.12),

$$p(V - b) = nRT \quad 6,06$$

In this equation V is the volume occupied by unit mass of gas, b is the co-volume, n the number of gram-molecules per gram, R the universal gas constant in mechanical units and p the mean gas pressure. It should be noted that the pressure p is not quite the same as the pressure p_r used in considering the external work done by the gases. There is in fact a pressure gradient in the gun, the pressure being highest at the breech and lowest at the base of the projectile. This pressure gradient is a consequence of the acceleration gradient which must clearly exist in the propellant gases, since the gases at the breech end are stationary while at the base of the projectile, they have an acceleration equal to that of the shot. The quantity p to be used in equation 6,06 is therefore a mean value suitably averaged over the pressure gradient. The relation between p and p_r is further discussed in Chapter VII. Equations 6,05 and 6,06 now give

$$JCz \bar{\sigma}_v T_0 = \frac{J \bar{\sigma}_v}{nR} Cz p(V - b) + A \int_0^x p_r dx$$

If we use the well known relation $\bar{\sigma}_p - \bar{\sigma}_v = nR/J$ (Section 2.13)* where $\bar{\sigma}_p$ is the mean specific heat at constant pressure and write $\gamma = \bar{\sigma}_p / \bar{\sigma}_v$ we have

$$\gamma - 1 = nR / J \bar{\sigma}_v \quad 6,07$$

Substitution for $J \bar{\sigma}_v$ then gives

$$Cz \frac{nR}{\gamma - 1} T_0 = \frac{Cz p(V - b)}{\gamma - 1} + A \int_0^x p_r dx \quad 6,08$$

* The factor $1/J$ is necessary to convert R from mechanical to heat units.

Introducing the "force constant" of the propellant (Section 2.11) defined by

$$F = nRT_0 \quad 6,09$$

we have

$$\frac{FCz}{\gamma - 1} = \frac{pCz(V - b)}{\gamma - 1} + A \int_0^x p_s dx \quad 6,10$$

Since V is the volume occupied by unit mass of gas, CzV is the total volume occupied by the gas at the instant considered. This includes the volume of the chamber K_0 plus the volume of the bore behind the driving band and less the volume occupied by the propellant still remaining solid. Hence if δ is the density of the solid propellant,

$$CzV = K_0 + Ax - C(1 - z)/\delta,$$

and 6,10 becomes

$$\frac{FCz}{\gamma - 1} = \frac{p}{\gamma - 1} \left[K_0 + Ax - C/\delta - Cz(b - 1/\delta) \right] + A \int_0^x p_s dx$$

In this equation $K_0 - C/\delta$ will be recognised as the initial free space behind the shot before firing. If we write

$$K_0 - C/\delta = Al \quad 6,11$$

l is the effective length of the free space in the chamber and we obtain Résal's equation in the form

$$\frac{FCz}{\gamma - 1} = \frac{p}{\gamma - 1} \left[A(x + l) - Cz(b - 1/\delta) \right] + A \int_0^x p_s dx \quad 6,12$$

6.07. Secondary energy losses

There now remain to be considered a number of secondary losses some of which will necessitate modifications to Résal's equation and others which we shall find negligible. The following are the energy losses to be considered—

- (a) kinetic energy of propellant gas and unburnt propellant (E_p),
- (b) kinetic energy of recoiling parts of gun and carriage (E_g),
- (c) heat energy lost to the gun (E_h),
- (d) strain energy of the gun (E_s),
- (e) energy lost in engraving the driving band and in overcoming friction up the bore (E_f),
- (f) rotational energy of the projectile (E_r).

Our object will be to give a quantitative estimate of the magnitude of these losses. In order to do so we shall quote formulae obtained or referred to in later chapters where a more detailed account of the theoretical and experimental investigations will be found.

6.08. Kinetic energy of propellant gas and unburnt propellant (E_p)

A detailed description of the motion of the propellant gas in the gun has been attempted by many ballisticians. The difficulties of the subject are, however, considerable and it is not possible to treat the problem adequately in a single section. A more complete discussion is given in Chapter VII and we shall here anticipate the results of that chapter.

It is there shown that the kinetic energy of the propellant gas and unburnt charge is given by

$$E_p = \frac{1}{6} C v^2 / g \text{ ft. lbs.} \quad 6,13$$

where C is in lbs. and v is the velocity of the projectile in ft./sec.

6.09. Kinetic energy of recoil (E_r)

We shall find that the energy of recoil is very small and approximate methods may be used in deducing an expression for it. If W, w are respectively the masses of recoiling parts and shot, the conservation of momentum gives, if we neglect the mass of gas,

$$u = wv/W$$

where u is the velocity of recoil. Hence the energy of recoil is given by

$$E_r = \frac{1}{2} W u^2 = \frac{w}{W} \frac{wv^2}{2g} \text{ ft. lbs.} \quad 6,14$$

The recoil energy is thus w/W times the energy of the shot. W is of the order of 100 w , i.e., this source of energy loss is of the order of one per cent.

6.10. Heat energy lost to the gun (E_h)

The derivation of the heat transfer equations and their solution are more completely discussed in Appendix II. We shall here quote a semi-empirical formula, proposed by C. K. Thornhill, which gives the amount of heat lost to the gun as proportional to the square of the shot velocity, i.e., proportional to the shot energy ; it is

$$E_h = \frac{0.38 d^{1.5} (x_3 + x_0) (T_0 - T_s)}{1 + 0.6 d^{2.175} / C^{0.8375}} \frac{v^2}{v_3^2} \text{ ft.lbs.} \quad 6,15$$

where T_0 is the adiabatic flame temperature, T_s is the initial temperature of the gun (both in °C.), C is the charge weight in lbs., d is the calibre of the gun in inches, x_3 is the shot travel to the muzzle in inches, x_0 is an equivalent chamber length, defined as $x_0 = K_0/A$ inches, v is the velocity of the shot at any instant and v_3 is the muzzle velocity, both in ft./sec. For present purposes (see Section 6.14), it is convenient to take E_h proportional to the shot-energy, which is a fairly good approximation and so formula 6,15 is quoted. A better approximation, also proposed by Thornhill, is to use the value at the muzzle as given by 6,15, in conjunction with the approximations that, for shot-travels greater than some 20 calibres, E_h is nearly proportional to $(x + x_0)$, and, for shot-travels less than some 20 calibres, E_h is nearly proportional to x , x being the shot-travel at any instant.

6.11. Strain energy of the gun (E_s)

It can be shown* that the application of a pressure p inside a closed cylinder whose internal and external diameters are respectively d_1 and d_2 results in an increase in volume of amount ρp per unit initial volume where

$$\rho = \frac{3}{3\lambda + 2\mu} \frac{d_1^2}{d_2^2 - d_1^2} + \frac{1}{\mu} \frac{d_2^2}{d_2^2 - d_1^2}$$

* A. E. H. Love. *Mathematical Theory of Elasticity.* Cambridge University Press, 3rd Edition. 1920. p. 143

In this expression the elastic constants λ , μ are related to Young's modulus E and Poisson's ratio σ of the material of the cylinder by

$$\lambda = \frac{\sigma E}{(1 + \sigma)(1 - 2\sigma)} \quad \mu = \frac{E}{2(1 + \sigma)}$$

The total work done in the expansion of the gun will therefore be $\frac{1}{2}\rho p^2$ per unit initial volume and hence, since the volume at any instant is $K_0 + Ax$, we have

$$E_s = \frac{1}{24}\rho(K_0 + Ax)p^2 \text{ ft.lbs.} \quad 6,16$$

where p is given in lbs. per sq. in., $(K_0 + Ax)$ in cu.ins. and E in lbs. per sq.in. Calculations in typical cases show that E_s is usually less than one per cent. of the energy of the shot.

6.12. The energy lost in engraving the driving band and in overcoming friction along the bore (E_f)

The amount of work required to engrave the driving band is not easy to calculate. A rough empirical value of the pressure developed in the chamber before the shot begins to accelerate freely has been given by Sugot as 400 kg./cm.² or 2.5 tons/sq. in., but the actual value must vary for different equipments.

After the band is fully engraved the frictional resistance probably drops to a small value but precise experimental results are not at present available. Such results as are available are discussed in Chapter XVI.

The work done against friction is unlikely to exceed about 4 or 5 per cent. of the kinetic energy of the shot. In what follows we shall take

$$E_f = 0.04 \times \frac{1}{2} wv^2/g \text{ ft.lbs.} \quad 6,17$$

the great advantage being that we preserve the form of the energy equation by so doing. This relation for E_f implies a resistive pressure proportional to the gas pressure and thus gives a resistance too small at the beginning and end of shot travel, but serious errors are not, we believe, introduced by this procedure.

6.13. The energy of rotation of the projectile (E_r)

Due to its rotation by the rifling, the shot possesses rotational as well as translational energy. If we suppose that the shot rotates once while it is moving forward a distance of n calibres, its angular velocity will be $2\pi v/nd$ where v is its forward velocity. Hence if k be the radius of gyration

$$E_r = \left(\frac{2\pi k}{nd}\right)^2 \frac{wv^2}{2g} \text{ ft.lbs.} \quad 6,18$$

For most shell $(2k/d)^2$ lies between 0.5 and 0.6 and a representative value of n is 30. Thus the rotational energy is about 0.6 per cent. of the translational energy of the shot and may well be neglected.

6.14. The modified form of R esal's equation

As already pointed out, equation 6,12 requires modification for secondary forms of energy.

This entails replacing the term $A \int_0^x p_s dx$ of equation 6,12 by

$$\frac{1}{2} wv^2 + E_p + E_g + E_h + E_s + E_f + E_r$$

Using the results of Sections 6.08—6.13 we see that we can neglect E_r and E_r as being very small in comparison with the first term and that the expression to replace $A \int_0^x p_r dx$ becomes*

$$1.05 \times \frac{1}{2} wv^2 + \frac{1}{6} Cv^2 + E_h$$

If therefore we write

$$w_1 = 1.05 w + \frac{1}{3}C, \tag{6,19}$$

we shall have, as the modified form of equation 6,12

$$\frac{FCz}{\gamma-1} = \frac{p}{\gamma-1} \left[A(x+l) - Cz(b-1/\delta) \right] + \frac{1}{2} w_1 v^2 + E_h \tag{6,20}$$

so that the form of 6,12 has been preserved except for the term E_h .

The form can be completely preserved by writing formula 6,15 in the form

$$E_h = \frac{1}{2} w_1 v^2 k/g \text{ ft.lbs.} \tag{6,21}$$

where w_1 is in lbs., v in ft./sec. and

$$k = \frac{0.76 d^{1.5} (x_3 + x_0) (T_0 - T_s) g}{w_1 (1 + 0.6 d^{2.175}/C^{0.8375}) v_3^2} \tag{6,22}$$

a rough estimate of the value of v_3 sufficing for the evaluation of k . If now we insert this value of E_h in 6,20 and write

$$\gamma' - 1 = (\gamma - 1) (1 + k) \tag{6,23}$$

we have

$$\frac{FCz}{\gamma'-1} = \frac{p}{\gamma'-1} \left[A(x+l) - Cz(b-1/\delta) \right] + \frac{1}{2} w_1 v^2 \tag{6,24}$$

where w_1 is given by 6,19 and γ' by 6,23 and 6,22.

* This includes an energy loss of one per cent. to allow for recoil (Section 6.09) and four per cent. to allow for friction (Section 6.12).

CHAPTER VII

THE EQUATION OF MOTION OF THE PROJECTILE

7.01. It was seen in Chapter VI that the loss of energy due to recoil and mechanical friction can be represented by an increase in the mass of the projectile of about 5 per cent. The equation of motion of the projectile is therefore

$$Ap_s = W \, dv/dt \quad 7,01$$

where $W = 1.05 \, w$ and p_s is the pressure on the base of the shot. In Section 6.06 it was noted that p_s differs from the mean pressure of the gases on which Résal's equation is based. In this chapter, the relation between these two pressures will be discussed in more detail, and the kinetic energy term in that equation will be determined.

There is, in general, a progressive fall in the gas pressure at any time, from the breech to the base of the projectile, and this pressure gradient is due mainly to two causes, namely, the inertia of the propellant gases, and the gas-frictional forces at the bore surface. The corresponding effects, which, in general, are not large, will be treated as if they were independent, and will be referred to as the *inertia* and the *friction* pressure-gradients respectively. Since, at most, the non-uniformity of the gas pressure along the barrel can only be introduced into the main ballistic equations as a correcting term, the free use of simplifying assumptions is justified in the determination of these pressure variations.

7.02. The inertia pressure-gradient*

Let V be the volume at any moment between the breech and shot-base and consider a cross section moving with the gases such that the volume behind it is σV , σ being a fraction. As a first approximation we shall assume that the volume behind this section always bears the same ratio to V , so that σ is independent of the time, t . We shall also assume that the volume of the solid portion of the charge is negligible compared with V ; this is obviously true except in the early stages of burning.

Let the density at the section be ρ , a function of σ and t . The mass of an element of volume $Vd\sigma$ at the section is therefore $\rho Vd\sigma$ and

$$\int_0^1 \rho V d\sigma = Cz \quad 7,02$$

where z is the gaseous fraction of the charge weight C .

If v is the velocity of the projectile, the velocity of the section is clearly σv and the momentum of the elementary volume $Vd\sigma$ is $\rho V v \sigma d\sigma$.

If p is the pressure at the section, the impressed force is $-A (\partial p / \partial \sigma) d\sigma$.
Hence

$$\sigma \frac{\partial (\rho V v)}{\partial t} = -A \frac{\partial p}{\partial \sigma} \quad 7,03$$

* This problem was originally considered by Lagrange and is known as the Lagrange Ballistic Problem. The approximation with regard to σ was made by him.

In deducing this equation we have assumed that the motion of the solid portion of the charge is negligible. Corner and Pack* have shown theoretically that this is approximately true, except in the last stages of burning when the acceleration may be appreciable; their deductions have received reasonable experimental confirmation.†

Integrating 7,03 from the section to the base of the projectile,

$$A(p - p_s) = \int_{\sigma}^1 \frac{\partial(\rho V v)}{\partial t} \sigma d\sigma$$

and, using 7,01,

$$\frac{p - p_s}{p_s} = \int_{\sigma}^1 \frac{\partial(\rho V v)}{\partial v} \frac{\sigma}{W} d\sigma \quad 7,04$$

The quantity $(p - p_s)/p_s$ is generally a small fraction; the variation of ρ with σ may therefore be neglected as a second-order effect in this equation. We therefore put $\rho V = Cx$ and obtain, by integrating,

$$\frac{p - p_s}{p_s} = \frac{(1 - \sigma^2) C}{2W} \frac{d(zv)}{dv} \quad 7,05$$

If p_b is the pressure on the breech (for which $\sigma = 0$)

$$p - p_s = (1 - \sigma^2) (p_b - p_s) \quad 7,06$$

With this pressure distribution the space-mean of pressure, p_m , is

$$p_m = \int_0^1 p d\sigma = \frac{1}{3} (2p_b + p_s) \quad 7,07$$

The quadratic distribution of pressure given by 7,06 is the best simple approximation known for the form of the pressure gradient due to the inertia of the gases, and it leads to the simple value 7,07 for the mean pressure, in terms of the pressures at the breech and the base of the shot.

7.03. A difficulty arises at the moment when the solid portion of the charge is completely burnt.

It was shown in Chapter IV that

$$z = (1 - f) (1 + \theta f)$$

and it is proved in Chapter VIII (*cf.* equation 8,15) that

$$v = K (f_0 - f)$$

where K is a constant depending on the loading conditions and f_0 is the value of f when the shot starts to move. For our present purpose we can take $f_0 = 1$ with negligible error.

* J. Corner and D. C. Pack. *The motion of cordite in a gun.* A.R.D. Theoretical Research Report No. 27/45.

† J. B. Goode and N. Lockett. *The space and time variation of pressure in the bore of a gun.* Experiments in a B.L. 6-inch gun. A.R.D. Ballistics Report No. 31/44.

We then have

$$d(zv)/dv = (1 - f)(2 - \theta + 3\theta f)$$

which has the value $(2 - \theta)$ at all-burnt.

But, after all-burnt, $z = 1$, so that

$$d(zv)/dv = 1.$$

It would, therefore, appear that the pressure ratio p/p_s suddenly drops in value, for all shapes except cord, at all-burnt.

This discontinuity seems to be inevitable if the solid portion of the charge never moves. It has, however, never been detected experimentally; this is probably due to the appreciable acceleration (referred to in Section 7.02) of the solid portion in the later stages of burning and may be explained as follows:—

If the mean velocity of the solid portion is u its momentum is $Cu(1 - z)$. The corresponding contribution to the pressure difference between breech and shot-base is

$$\frac{C}{A} \frac{du(1 - z)}{dt} = \frac{p_s C}{W} \frac{du(1 - z)}{dv} = \frac{p_s C}{W} \left[(1 - z) \frac{du}{dv} - u \frac{dz}{dv} \right]$$

using 7.01.

Now, du/dv is the ratio of the accelerations of the solid portion and the projectile respectively. This ratio is small except in the last stages of burning; then $(1 - z)$ is small. The first term in the bracket can, therefore, always be neglected. The total pressure difference between breech and shot-face is therefore given by

$$\begin{aligned} \frac{p_b - p_s}{p_s} &= \frac{C}{2W} \left[\frac{d(zv)}{dv} - 2u \frac{dz}{dv} \right] \\ &= \frac{C}{2W} \left[z + (v - 2u) \frac{dz}{dv} \right] \end{aligned}$$

Thus the discontinuity does not occur if u increases steadily to the value $\frac{1}{2}v$ at all-burnt.

We may, therefore, conclude that 7.05 gives the inertia pressure-gradient at all times except during the period approaching all-burnt; during this period the coefficient $d(zv)/dv$ undergoes a gradual transition towards the value unity at all-burnt.

7.04. The friction pressure-gradient

The velocity of the gas stream is not constant over a cross-section of the bore, as has been tacitly assumed in the last sections, but near the bore surface there is a turbulent boundary layer, across which the gas velocity decreases to zero at the bore surface. The theory of the boundary layer in the gas flow in a gun-barrel has been developed by Hicks and Thornhill* taking some account both of the non-steadiness and non-uniformity of the flow.

On the assumption that the bore surface is smooth in the hydrodynamical sense, the skin-friction $\tau_0(\sigma, t)$ is obtained as

$$\tau_0 = \rho \sigma^2 v^2 / a^2 \eta_1^{2/n}$$

where a and n are constants and η_1 is a non-dimensional parameter given by

$$\eta_1^{1+3/n} = K(t) R/a^3$$

* E. P. Hicks and C. K. Thornhill. *The heating of a gun barrel by the propellant gases*. A.C.3119, I.B.146, reproduced as Appendix II p. 271.

R is the Reynold's number, $\rho\sigma^2v/A\mu$, of the main gas flow, in which μ is the viscosity of the propellant gases ; $K(t)$ is another non-dimensional parameter, dependent on the time t , which is zero at the commencement of motion of the shot, and rises rapidly to an asymptotic value of order 4 or 5.

The pressure decline due to gas friction at the bore surface is then given by

$$A(p - p_s) = \int_{\sigma}^1 \tau_0 S d\sigma$$

where S is the surface area of that part of the bore behind the shot.

This may be evaluated as

$$p - p_s = [p_b - p_s] [1 - \sigma^{(3n+5)/(n+3)}] \quad 7,08$$

where

$$p_b - p_s = \frac{(n+3) S \rho_m v^2}{(3n+5) A} \left[\frac{A\mu}{\rho_m v V a^n K(t)} \right]^{2/(n+3)} \quad 7,09$$

and ρ_m is the space-mean density of the gases.

Calculations of this pressure-drop have been made by Hicks and Thornhill* for several theoretical internal-ballistic solutions corresponding to different guns. They show that the pressure-drop due to gas friction is small compared with the inertia pressure-drop, except when the shot has nearly reached the muzzle. This enables extensive simplifications to be made in the expression 7,09 ; for, when the shot is near the muzzle, $K(t)$ may be taken as constant and ρ_m may be replaced by C/V . The expression then reduces to

$$p_b - p_s = k_1 (Cv^2/d^3) (\mu d^2/Cv)^{2/(n+3)}$$

where k_1 is a non-dimensional constant and d is the bore diameter. The viscosity μ will not vary much between different propellants and the appropriate value of the index n for flow in gun barrels being 11.3, the power $2/(n+3)$ is only about one-seventh. Thus, for conventional guns at least, the non-dimensional quantity $(\mu d^2/Cv)^{2/(n+3)}$ will not vary very much, and may be replaced by a mean constant value k_2 .

Then, approximately,

$$p_b - p_s = k Cv^2/d^3 \quad 7,10$$

where $k = k_1 k_2$ is again a non-dimensional constant.

Comparison between these expressions and detailed calculations of the expression 7,09 shows that good agreement is obtained in all cases with

$$\begin{aligned} k_1 \mu^{2/(n+3)} &= k_1 \mu^{0.14} = 9.53 \times 10^{-3} \text{ in c.g.s. units.} \\ &= 6.53 \times 10^{-3} \text{ in ft. lb. sec. units.} \end{aligned}$$

or, more simply,

$$k = 1.10 \times 10^{-3}$$

The simplified expression 7,10 is therefore quite adequate for estimating the theoretical pressure difference due to gas-frictional forces. In practice, the constant k may have a higher numerical value, since the bore surface will not be hydrodynamically smooth, as has been assumed, at the high Reynold's numbers, 10^6 to 10^9 of gas flow in gun-barrels.

† E. P. Hicks and C. K. Thornhill. *The pressure gradient along a gun-barrel.* A.R.E. Report No. 2/49.

7.05. The total pressure-gradient

A comparison between the pressure differences between breech and shot-base due to inertia and frictional effects can now be made. For, when the projectile is near the muzzle, 7,10 gives approximately,

$$[p_b - p_s] \text{ friction} = kCv^2/d^3,$$

and 7,05 gives

$$[p_b - p_s] \text{ inertia} = \frac{1}{2} p_s C/W.$$

Thus

$$\frac{[p_b - p_s] \text{ friction}}{[p_b - p_s] \text{ inertia}} = \frac{2kWv^2}{d^3 p_s}$$

This ratio clearly increases steadily as the shot travels towards the muzzle ; it reaches a value of about one-third at the muzzle in a typical case, for which $W/d^3 = 0.5 \text{ lb./c.in.}$, $v = 3000 \text{ ft./sec.}$ and $p_s = 5 \text{ tons/sq.in.}$ The muzzle value of this fraction would, of course, be higher in a long gun designed to give a high muzzle velocity.

Combining the results given in 7,05 and 7,10 we obtain, for the total difference,

$$p_b - p_s = p_s [\lambda + 2k Wv^2/d^3 p_s] C/2W \quad 7,11$$

where $\lambda = (1 - f)(30f + 2 - \theta)$, for $1 > f > 0$

and $\lambda = 1$ after all-burnt, with an appropriate transition region.

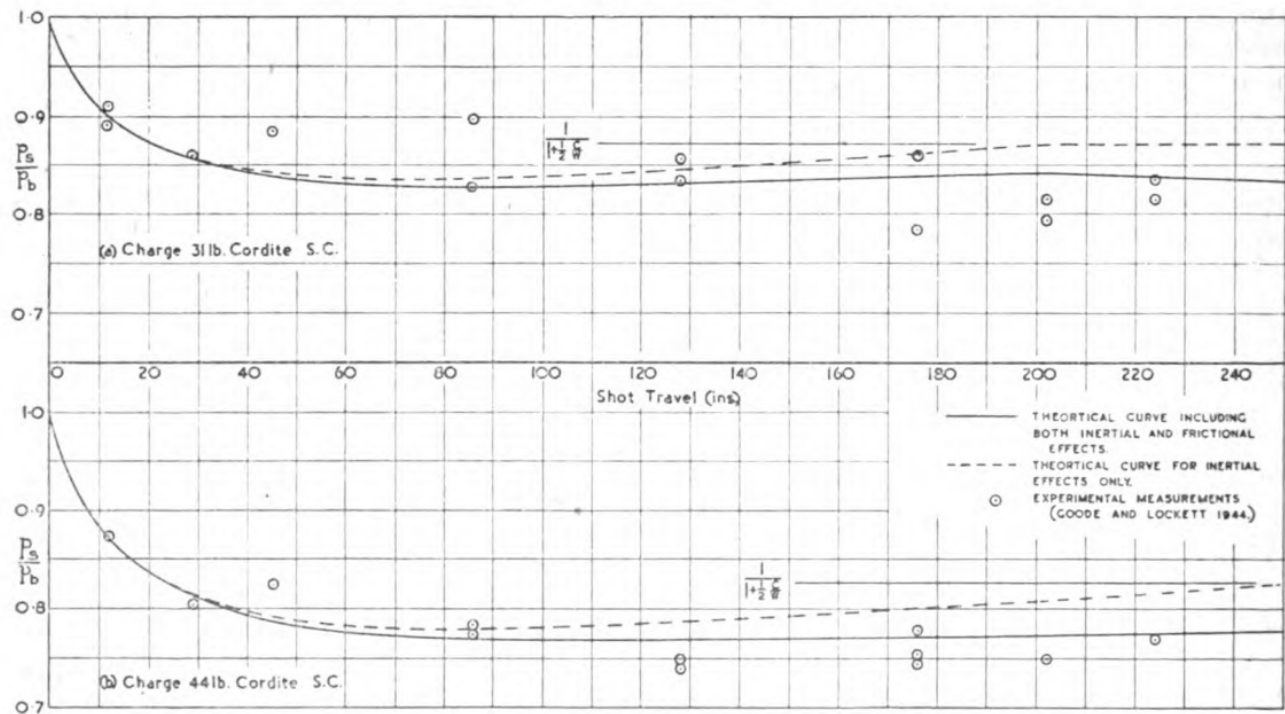

Fig. 7.01

The experimental measurements made by Goode and Lockett, which are thought to be the best at present available, do not enable a reliable practical value of k to be deduced for comparison with the theoretical value, but they do indicate that the theoretical value is of the right order of magnitude. Figure 7.01 show the comparison between Goode and Lockett's experimental measurements of p_s/p_b and the curve for p_s/p_b against shot-travel, derived for their cases by the methods so far outlined in this chapter.

7.06. The mean pressure and the equation of motion

Since, as has been shown, the frictional pressure-drop is small compared with the inertia pressure-drop for most of the period of shot travel, the space distribution of the frictional pressure-drop (7,08) may be taken, for convenience, as similar to the quadratic distribution of the inertia pressure-drop. Then equation 7,06 holds for the combined effects.

Equation 7,11 may be written

$$p_b - p_s = p_s F(t) C/2W \quad 7,12$$

where $F(t)$ is a function of t given by

$$F(t) = \frac{d(xv)}{dv} + \frac{2k W v^2}{d^3 p_s}$$

to near all-burnt, and undergoing a gradual transition to

$$F(t) = 1 + 2kWv^2/d^3p_s$$

at all-burnt and after.

Then 7,06 becomes

$$p = p_s [1 + \frac{1}{2}(1 - \sigma^2) F(t) C/W] \quad 7,13$$

and the space-mean of pressure at any time is

$$p_m = \int_0^1 p d\sigma = p_s [1 + \frac{1}{3} F(t) C/W] = \frac{1}{3} [2p_b + p_s]$$

The equation of motion 7,01 may then be written

$$A p_m = w_1 dv/dt \quad 7,14$$

where the modified shot mass w_1 is given by

$$w_1 = 1.05 w + \frac{1}{3} CF(t) \quad 7,15$$

7.07. The kinetic energy term in Résal's equation

The kinetic energy of an element of the gases is $\frac{1}{2} \rho V \sigma^2 v^2 d\sigma$; hence the kinetic energy of the gases at any moment is

$$\int_0^1 \frac{1}{2} \rho V \sigma^2 v^2 d\sigma$$

As in Section 7.02 the variation of ρ with σ may be neglected as a second-order effect and ρV may be replaced by Cz . The integral then becomes $\frac{1}{6} Cz v^2$ and, combining this with the kinetic energy of the shot and the work done on recoil and against mechanical friction, we have, for the kinetic energy term in Résal's equation, $\frac{1}{2} w_2 v^2$

where

$$w_2 = 1.05 w + \frac{1}{3} Cz \quad 7,16$$

It should be noted, however, that Lagrange's approximation will not give so good a value for the kinetic energy of the gases as it does for their momentum, since it takes no account of radial motion and turbulence. The true kinetic energy term may therefore be slightly greater and w_2 may exceed the above value by a small amount.

It will be seen in the next chapter that if w_1 and w_2 can be assumed to be constant and equal, the solution of the ballistic equations is facilitated. Since in each case the varying term is in the nature of a correction this may be done without serious loss of accuracy. The function $F(t)$ increases with time from zero to something greater than unity, while z increases from zero to unity at all-burnt and thereafter remains at that value; moreover, the true w_2 may be somewhat greater than the value given in 7,16.

We approximate by assuming a mean value, unity, for both these functions and so obtain

$$w_1 = w_2 = 1.05 w + \frac{1}{3}C \quad 7,17$$

This is the result foreshadowed in Section 6.14.

With this approximation the relations between the pressures become

$$\frac{p_b}{1 + \frac{1}{2}C/W} = \frac{p_m}{1 + \frac{1}{3}C/W} = \frac{p}{1 + \frac{1}{2}(1 - \sigma^2)C/W} = p_s \quad 7,18$$

If it is assumed that the solid portion of the charge is always evenly distributed between the breech and the base of the shot during the burning, so that the mean density of solid and gaseous charge is $\rho = C/V$ and fluid friction is neglected,

$$p - p_s = \frac{1}{2} p_s (1 - \sigma^2) C/W$$

$$p_m = p_s (1 + \frac{1}{3}C/W)$$

and the kinetic energy of the charge is $\frac{1}{2}Cv^2$.

Then

$$w_1 = w_2 = 1.05 w + \frac{1}{3}C$$

It was with these assumptions that this result was formerly derived.

Throughout this chapter, it has always been assumed that the ratio C/W is not greater than that for conventional guns. Various writers* have agreed that, considering inertia effects only, and neglecting the effect of the unburnt portion of the charge, a constant value of the ratio p_b/p_s is deduced which is not significantly different from $(1 + \frac{1}{2}C/W)$ for values of C/W up to unity, even when second and third order terms in C/W are taken into account. It seems probable therefore that the results outlined in this chapter may be applied for values of C/W up to unity at least, without very serious error.

7.08. Pressure waves

The preceding paragraphs have dealt with changes of pressure which are continuous from one region of the gas to another; another type of pressure variation must also be considered. When any sudden change in pressure arises in the gas from any cause, a pressure wave will travel outwards from the centre of the disturbance with the velocity of sound in the gas; at

* R. H. Kent. *Some special solutions for the motion of the powder gas.* Physics, Vol. 7, No. 9, 1936, p. 319.
 W. A. Hepner. *Solutions for the motion of the powder gas in a cylindrical gas-tube.* A.R.D. Ballistics Report 40/43, AC. 4297, IB.192.

the temperatures existing in the gases, this is some 3,000 to 4,000 ft.sec., and is considerably higher than the velocity of the projectile : in the absence of any influence to increase the amplitude of this pressure wave, it will be attenuated, but may be reflected several times at the breech end of the chamber and at the base of the projectile.

This problem was considered by Lagrange* and an example of this type of wave was worked out in a simplified case by Love and Pidduck ;† they assumed with Lagrange that the propellant is all-burnt before the projectile starts to move and the start of the forward movement of the projectile then causes a local drop of pressure which is initially transmitted rearward ; this rarefaction wave is reflected several times at the two ends of the gas column : it follows that the fractional pressure-drop oscillates, and the maximum value which they deduce is $1 + C/w$. Such waves have not been detected in experimental firings.

On the other hand, if a wave of excess pressure passes over a section of unburnt propellant, the rate of burning will be increased locally, leading to a locally-increased quantity of gas and thus a further excess of pressure. Thus the presence of unburnt propellant provides the mechanism for reinforcing any waves of excess pressure which may exist, or in fact which may be set up by any local focus of excess pressure. Such foci of excess pressure can in fact be set up whenever the ignition system causes the main propellant charge to begin to burn at one or more local centres rather than simultaneously throughout the charge ; pressure waves from this cause have been frequently observed, and have on occasion reached catastrophic proportions : however, the measurement of pressure-time curves in gun chambers is a routine method of determining, by the absence of pressure peaks, the adequacy of the ignition system.

* Lagrange. Collected Works. Vol. 7.

† A. E. H. Love and F. B. Pidduck. *The Lagrange ballistic problem*. Phil. Trans. A. Vol. 22, 1921-2, p. 167.

CHAPTER VIII

SOLUTION FOR LINEAR RATE OF BURNING

THE HUNT-HINDS SYSTEM OF INTERNAL BALLISTICS

8.01. The system of Internal Ballistics described in this chapter was first given in a course of lectures at the Military College of Science in 1929 ; it has, since then, been amplified by Professor C. J. Tranter and Mr. M. M. Nicolson and is still in use at the College. Some suggestions made by Mr. A. W. Goldie have been incorporated in the text.

The main objects of the solution are to obtain, for a given set of loading conditions,

- (a) The pressure-space curve,
- (b) The maximum pressure,
- (c) The muzzle velocity.

The pressure-space curve, which is mainly used by the gun-maker in designing the gun, is not usually required very accurately, since factors of safety are applied in the course of the calculation of gun stresses. The maximum pressure and muzzle velocity are generally required to a greater degree of accuracy.

The system is based on equations 6,20, 7,14, 4,01 and 5,04 (with $\alpha = 1$), which are here summarised :—

$$FCz = p \{ A (x + l) - Cz (b - 1/\delta) \} + \frac{1}{2} (\gamma - 1) w_1 v^2 \quad 8,01$$

$$w_1 v \, dv/dx = Ap \quad 8,02$$

$$z = (1 - f) (1 + \theta f) \quad 8,03$$

$$Ddf/dt = - \beta p \quad 8,04$$

The term E_h of 6,20 is omitted from equation 8,01, but the value of γ is not adjusted therefor. Compensation for heat losses need only be made in the solution for muzzle velocity and this is effected (as will be seen later) by means of an empirical correction to the thermodynamic efficiency. Other losses are allowed for by adjusting the "equivalent mass moved," w_1 , as indicated in equation 7,17. The form co-efficient θ is assumed to be constant and the rate of burning is assumed to be proportional to the pressure.

The quantity $(b - 1/\delta)$ is small and is neglected in many systems of internal ballistics. The equations can, however, be solved without restricting the value of this quantity and the complete solution is given in Sections 8.02 to 8.09. In subsequent sections approximations are introduced to facilitate numerical calculation ; for the calculation of the pressure-space curve this quantity is neglected ; for the calculation of maximum pressure and muzzle velocity it is treated as a small quantity. A method of calculating the pressure-space curve to this order of accuracy is also given, as this is occasionally required in ballistic calculations.

8.02. Reduction of the equations

It is proposed eventually to produce a solution which may be tabulated ; for this purpose it is essential to deal in quantities which are freed as far as possible from numerical constants representing the loading conditions ; moreover, difficulty in dealing with various systems of units will be reduced if the quantities handled are dimensionless.

The following substitutions are therefore made :—

$$\xi = 1 + x/l \quad 8,05$$

$$\eta = vAD/FC\beta \quad 8,06$$

$$\zeta = pAl/FC \quad 8,07$$

$$M = A^2D^2/FC\beta^2w_1 \quad 8,08$$

so that effectively, ξ , η and ζ are dimensionless variables representing shot travel, shot velocity and gas pressure.

The equations for solution then become

$$z = \zeta (\xi - Bz) + \frac{1}{2} (\gamma - 1) \eta^2/M \quad 8,09$$

where

$$B = (b - 1/\delta) C/Al \quad 8,10$$

$$M\zeta = \eta d\eta/d\xi \quad 8,11$$

$$z = (1 - f) (1 + \theta f) \quad 8,12$$

$$\zeta = - \eta df/d\xi \quad 8,13$$

8.03. Initial conditions

The shot does not start to move immediately after the ignition of the charge ; initially the charge burns under closed-vessel conditions and the pressure rises until it is sufficient to cause the driving band to be engraved by the rifling. The velocity of the shot and the increase in chamber capacity during the engraving are negligible.

Using suffix $_0$ to indicate the values of the variables at "shot-start," $\xi_0 = 1$ and $\eta_0 = 0$; equation 8,09 then gives

$$z_0 = \zeta_0 (1 - Bz_0)$$

or

$$z_0 = \zeta_0/(1 + B\zeta_0) \quad 8,14$$

where $\zeta_0 = p_0Al/FC$ and p_0 is the "shot-start" pressure.

8.04. The solution of the equations

While the charge is burning after shot start, i.e., while $z_0 \leq z \leq 1$, the variables are ξ , η , ζ , z and f and elimination of any three from the equations 8,09 to 8,13 will result in a differential equation in the remaining two. It is found to be most convenient to obtain the equation relating ξ and η and to use η (i.e., effectively the shot velocity) as the independent variable.

8.05. Solution during the burning of the charge

Equations 8,11 and 8,13 give

$$d\eta = - Mdf$$

Hence

$$\eta = M (f_0 - f)$$

or

$$f = f_0 - \eta/M \quad 8,15$$

Hence, from equation 8,12,

$$z = z_0 + (1 - \theta + 2\theta f_0) \eta/M - \theta\eta^2/M^2 \quad 8,16$$

Eliminating ζ between 8,09 and 8,11 gives

$$(\xi - Bz) \eta d\eta/d\xi = Mz - \frac{1}{2} (\gamma - 1) \eta^2 \quad 8,17$$

which can be written*

$$\frac{\eta d\eta}{(a - \eta)(b + \eta)} = \frac{d\xi}{N(\xi - Bz)} \quad 8,18$$

where

$$N = M/\theta' \quad 8,19$$

$$\theta' = \theta + \frac{1}{2} (\gamma - 1) M \quad 8,20$$

$$ab = MNz_0 \quad 8,21$$

$$a - b = N(1 - \theta + 2\theta f_0) \quad 8,22$$

Since

$$z_0 = (1 - f_0)(1 + \theta f_0)$$

$$1 - \theta + 2\theta f_0 = \sqrt{\{(1 + \theta)^2 - 4\theta z_0\}}$$

Hence

$$a - b = N\sqrt{\{(1 + \theta)^2 - 4\theta z_0\}} \quad 8,23$$

and

$$\begin{aligned} a + b &= \sqrt{\{(a - b)^2 + 4ab\}} \\ &= N\sqrt{\{(1 + \theta)^2 + 2(\gamma - 1)Mz_0\}} \end{aligned} \quad 8,24$$

Equations 8,23 and 8,24 determine a and b in terms of the loading conditions. Equation 8,16 may now be written

$$z = z_0 + (a - b) \eta/MN - \theta\eta^2/M^2 \quad 8,25$$

It will be convenient to write

$$\int_0^\eta \frac{\eta d\eta}{(a - \eta)(b + \eta)} = \log H \quad 8,26$$

so that

$$\log H = -\frac{a}{a+b} \log(1 - \eta/a) - \frac{b}{a+b} \log(1 + \eta/b) \quad 8,27$$

Then equation 8,18 becomes

$$\frac{dH}{H} = \frac{d\xi}{N(\xi - Bz)}$$

* No confusion need arise between the b introduced here and the co-volume b used previously.

or
$$\frac{d\xi}{dH} - \frac{N\xi}{H} = - \frac{NBz}{H}$$

whence
$$\xi H^{-N} - 1 = - Bc,$$

or
$$\xi = (1 - Bc) H^N \tag{8,28}$$

where
$$c = N \int_1^H H^{-N-1} z dH, \tag{8,29}$$

the initial values of ξ and H being unity.

Since H and z are functions of η (equations 8,27 and 8,25) we have now obtained ξ as a function of η .

The gas pressure can be deduced from equations 8,11 and 8,18 ;

$$\zeta = \frac{(a - \eta)(b + \eta)}{MN(\xi - Bz)} \tag{8,30}$$

From equations 6,06, 6,09, 6,10, 6,12, 8,05, 8,07 and 8,10 the mean temperature of the gases at any instant can be deduced in the form

$$T = T_0 \zeta (\xi - Bz)/z \tag{8,31}$$

and, using 8,09,

$$T = T_0 [1 - \frac{1}{2} (\gamma - 1) \eta^2/Mz] \tag{8,32}$$

8.06. Alternative expressions for ξ and ζ

If ξ' is the value of ξ , for the same value of η , when $B = 0$,

$$\xi' = H^N \tag{8,33}$$

and equations 8,28 and 8,29 may be written,

$$\xi = \xi' (1 - Bc) \tag{8,34}$$

$$c = \int_{1/\xi'}^1 z d(1/\xi') \tag{8,35}$$

Then
$$\xi - Bz = \xi' (1 - Bc') \tag{8,36}$$

where
$$c' = c + z/\xi' \tag{8,37}$$

If ζ' is the value of ζ , for the same value of η , when $B = 0$,

$$\zeta' = (a - \eta)(b + \eta)/MN\xi' \tag{8,38}$$

and equation 8,30 may be written,

$$\zeta = \zeta'/(1 - Bc') \tag{8,39}$$

The coefficients c and c' may be conveniently evaluated as follows :—
Putting $B = 0$ in equation 8,17,

$$Mz = \xi' \eta \, d\eta/d\xi' + \frac{1}{2} (\gamma - 1) \eta^2$$

Hence

$$\begin{aligned} Mzd(1/\xi') &= -\eta \, d\eta/\xi' + \frac{1}{2} (\gamma - 1) \eta^2 d(1/\xi') \\ &= -\gamma \eta \, d\eta/\xi' + \frac{1}{2} (\gamma - 1) [\eta^2 d(1/\xi') + 2 \eta d\eta/\xi'] \end{aligned}$$

and

$$Mc = M \int_{1/\xi'}^1 z \, d(1/\xi') = \gamma \int_0^\eta (\eta/\xi') \, d\eta - \frac{1}{2} (\gamma - 1) \eta^2/\xi' \quad 8,40$$

Putting $B = 0$ in equation 8,09,

$$Mz/\xi' = M\zeta' + \frac{1}{2} (\gamma - 1) \eta^2/\xi'$$

Hence

$$Mc' = M (c + z/\xi') = M\zeta' + \gamma \int_0^\eta (\eta/\xi') \, d\eta \quad 8,41$$

The integral in these expressions for c and c' cannot be evaluated in algebraic terms except for particular values of z_0 , notably for $z_0 = 0$; its evaluation by quadrature in any particular case presents no difficulty.

Alternative expressions for c and c' may be obtained by integrating by parts in equation 8,35. The results are

$$c = z_0 - z/\xi' + \int_z^{z_0} (1/\xi') \, dz \quad 8,35a$$

$$c' = z_0 + \int_{z_0}^z (1/\xi') \, dz \quad 8,37a$$

It is interesting to note that if ξ' and ζ' are defined by the expressions :—

$$\ln \xi' = \int_0^\eta \frac{\eta \, d\eta}{Mz - \frac{1}{2} (\gamma - 1) \eta^2} = M \int_f^{f_0} \frac{(f_0 - f) \, df}{z - \frac{1}{2} (\gamma - 1) M (f_0 - f)^2}$$

$$\zeta' = [z - \frac{1}{2} (\gamma - 1) \eta^2/M]/\xi' = [z - \frac{1}{2} (\gamma - 1) M (f_0 - f)^2]/\xi'$$

which are derived from 8,17, 8,15 and 8,09, equations 8,34 and 8,39 give the solution for the general form function $z = \varphi(f)$.

8.07. "All-burnt"

Denoting by suffix ₂ the values of the variables at the instant when the charge is completely consumed, we have $f_2 = 0$; hence, from equation 8,15

$$\eta_2 = Mf_0 \quad 8,42$$

whence, using 8,22,

$$\eta_2 = M \{ \theta - 1 + (a - b)/N \} / 2\theta \quad 8,43$$

When $\theta = 0$ we have, from 8,16,

$$\eta_2 = M (1 - z_0) \tag{8,44}$$

The values of ξ_2 and ζ_2 can be determined from 8,34 and 8,39.

If the value of ξ_2 so deduced is greater than the value of ξ at the muzzle, the charge will not be completely consumed in the bore.

Values of η_2/M are given in Table 8.04.

8.08. Solution when $\theta' = 0$

The solution becomes indeterminate in one particular case, namely, when $\theta = -\frac{1}{2}(\gamma - 1)M$; then $\theta' = 0$ and N becomes infinite. Equation 8,17 then becomes

$$\frac{\eta d\eta}{\eta + Mnz_0} = \frac{d\xi}{n(\xi - Bz)}$$

where

$$1/n = 1 - \theta + 2\theta f_0 = \sqrt{\{(1 + \theta)^2 - 4\theta z_0\}}$$

The solution is

$$\xi = \xi' (1 - Bc)$$

where

$$\xi' = e^{m\eta} (1 + \eta/Mnz_0)^{-Mn^2z_0}$$

and

$$c = \int_{1/\xi'}^1 z d(1/\xi')$$

We then have

$$\zeta = \frac{\eta + Mnz_0}{Mn(\xi - Bz)}$$

All-burnt occurs when

$$\eta_2 = Mf_0 = M(\theta - 1 + 1/n)/2\theta$$

In the following sections we shall refer to this case only when the results obtained are affected thereby ; where no reference is made the results may be considered to include this case.

8.09. After " All-burnt "

During the subsequent motion it will be more convenient to use ξ as independent variable. The form function z is now constant, its value being unity.

Equation 8,09 now becomes

$$1 = \zeta (\xi - B) + \frac{1}{2} (\gamma - 1) \eta^2/M$$

Differentiating and using 8,11 leads to

$$(\xi - B) d\zeta + \gamma \zeta d\xi = 0$$

which integrates to

$$\zeta (\xi - B)^\gamma = \zeta_2 (\xi_2 - B)^\gamma = \Phi \tag{8,45}$$

where Φ is a constant depending on the loading conditions.

Hence

$$\begin{aligned}\eta^2 &= \{1 - \zeta(\xi - B)\} 2M/(\gamma - 1) \\ &= \{1 - \Phi(\xi - B)^{1-\gamma}\} 2M/(\gamma - 1)\end{aligned}\quad 8,46$$

Equations 8,45 and 8,46 thus give the pressure and velocity for any value of ξ greater than ξ_2 . The mean temperature of the gases at any instant is obtained by putting $x = 1$ in equation 8,31 ;

$$T = T_0 \zeta(\xi - B)$$

Using suffix ₃ to denote values at the muzzle, the thermodynamic efficiency of the gun is

$$E = 1 - T_3/T_0 = 1 - \Phi(\xi_3 - B)^{1-\gamma} \quad 8,47$$

Whence, using 8,06 and 8,08,

$$v_3^2 = 2 FCE/(\gamma - 1) w_1 \quad 8,48$$

This completes the solution when no restriction is placed on the value of $(b - 1/\delta)$.

8.10. The pressure-space curve

When a high order of accuracy is not required in the calculation of the pressure-space curve we can neglect the small quantity $(b - 1/\delta)$ altogether and write $B = 0$. Equation 8,14 then becomes

$$x_0 = \zeta_0$$

and equations 8,33 and 8,38 may be used for the calculation of ξ and ζ . Retaining the notation ξ' and ζ' to denote values when $B = 0$,

$$\xi' = H^N \quad 8,33$$

$$\zeta' = (a - \eta)(b + \eta)/MN\xi' \quad 8,38$$

After all-burnt equation 8,45 may be used in the modified form

$$\zeta'(\xi')^\gamma = \zeta_2'(\xi_2')^\gamma = \Phi' \quad 8,49$$

Φ' being the value of Φ when $B = 0$.

Choosing a series of values of η from 0 to η_2 and evaluating ξ' and ζ' and thence x and p we obtain points on the curve up to all-burnt. Using a series of values of ξ' from ξ_2' to ξ_3 the curve can be completed.

The calculation is facilitated by using Tables 8.01, 8.04 and 8.06, which give $\log H$ as a function of η/a , and b/a , η_2/M as a function of θ and ζ_0 , and Φ' as a function of $(\gamma - 1)M$, ζ_0 and θ .

The value of η at the point at which the pressure is a maximum can be determined by putting $d\zeta' = 0$ in equation 8,38. Differentiating logarithmically and denoting values at this point by suffix ₁,

$$\frac{d\xi_1'}{\xi_1'} = \frac{d\eta_1}{b + \eta_1} - \frac{d\eta_1}{a - \eta_1} = \frac{(a - b - 2\eta_1) d\eta_1}{(a - \eta_1)(b + \eta_1)}$$

But, from 8,18,

$$\frac{d\xi_1'}{\xi_1'} = \frac{N\eta_1 d\eta_1}{(a - \eta_1)(b + \eta_1)}$$

Hence

$$\eta_1 = (a - b)/(N + 2) \tag{8,50}$$

and ξ_1' and ζ_1' can be evaluated from equations 8,33 and 8,38.

If $\eta_1 > \eta_2$ there is no true maximum and the greatest pressure occurs at all-burnt.

When

$$\theta' = 0$$

$$\xi' = e^{m\eta} (1 + \eta/Mn\zeta_0)^{-Mn^2\zeta_0}$$

$$\zeta' = (\eta + Mn\zeta_0)/Mn\xi'$$

$$\eta_1 = 1/n$$

$$1/n = \sqrt{\{(1 + \theta)^2 - 4\theta\zeta_0\}}$$

8.11. Solution when B is small

We will now consider what simplifications to the solution of Sections 8,02 to 8,09 can be effected by treating B as a small quantity compared with ξ/z . Terms involving B need not be calculated to the same degree of accuracy as that of other terms ; the shot-start pressure, moreover, is generally small enough to ensure that ζ_0 is small compared with unity. Coefficients of B in the solution are therefore calculated for zero shot-start pressure.

The first simplification arises in equation 8,14 which now becomes

$$z_0 = \zeta_0 \tag{8,51}$$

and we can replace z_0 by ζ_0 wherever it occurs in the solution. We notice in particular that η_2 is now independent of B.

The second simplification is in the coefficients c and c' (equations 8,40 and 8,41), which can now be evaluated in algebraic terms. When ζ_0 is neglected we have

$$z_0 = 0$$

$$a = N(1 + \theta)$$

$$b = 0$$

$$1/H = 1 - \eta/a$$

Hence

$$1/\xi' = (1 - \eta/a)^N$$

and

$$\begin{aligned} \int_0^{\eta} (\eta/\xi') d\eta &= \int_0^{\eta} (1 - \eta/a)^N \eta d\eta \\ &= a^2 \left[\frac{1 - (1 - \eta/a)^{N+1}}{N + 1} - \frac{1 - (1 - \eta/a)^{N+2}}{N + 2} \right] \\ &= (1 + \theta)^2 \lambda \end{aligned}$$

where

$$\lambda = \frac{N^2 [1 - \{1 + (N + 1)\eta/a\} \{1 - \eta/a\}^{N+1}]}{(N + 1)(N + 2)} \tag{8,52}$$

which is a function of N and $\eta/(1 + \theta)$.

When $\theta' = 0$

$$\lambda = 1 - [1 + \eta/(1 + \theta)] \exp[-\eta/(1 + \theta)]$$

Hence, from equations 8,40 and 8,41,

$$c = \gamma\lambda (1 + \theta)^2/M - \frac{1}{2} (\gamma - 1) \eta^2/M\xi' \quad 8,53$$

and

$$c' = \gamma\lambda (1 + \theta)^2/M + \zeta' \quad 8,54$$

The third simplification occurs in the expression for Φ in equation 8,45. We have

$$\begin{aligned} \Phi &= \zeta_2 (\xi_2 - B)^\gamma \\ &= (\xi_2 - B)^{\gamma-1} [1 - \frac{1}{2} (\gamma - 1) \eta_2^2/M] \\ &= (\xi_2')^{\gamma-1} [1 - \frac{1}{2} (\gamma - 1) \eta_2^2/M] (1 - Bc_2')^{\gamma-1} \end{aligned} \quad 8,55(a)$$

from equation 8,36.

Since B is small, this can be written

$$\Phi = \Phi' [1 - (\gamma - 1) Bc_2'] \quad 8,55(b)$$

where

$$\Phi' = (\xi_2')^{\gamma-1} [1 - \frac{1}{2} (\gamma - 1) \eta_2^2/M] \quad 8,56$$

8.12. Tabular solution for maximum pressure

In a good many ballistic calculations the value of the maximum pressure in the bore is required without reference to the position of the shot when the maximum occurs. It is then more convenient to be able to calculate it direct from the loading conditions. Moreover, its value is generally required with greater accuracy than would be obtained by using the method indicated in Section 8.10.

In this section we shall investigate a method of determining ζ_1' (i.e. the value of ζ_1 when $B = 0$) in tabular form direct from the loading conditions ; in Section 8.13 a correction will be obtained for B, treated as a small quantity.

The equations for the calculation of ζ_1' are

$$\begin{aligned} z_0 &= \zeta_0 \\ \eta_1 &= (a - b)/(N + 2) \\ \xi_1' &= H_1^N \\ \zeta_1' &= (a - \eta_1) (b + \eta_1)/MN\xi_1' \end{aligned}$$

Equation 8,24 can be written

$$N^2 (1 + \theta)^2 = (a + b)^2 - 2 (\gamma - 1) N^2 M \zeta_0$$

Hence, using 8,21,

$$\begin{aligned} \frac{M\zeta_0}{(1+\theta)^2} &= \frac{Nab}{(a+b)^2 - 2(\gamma-1)Nab} \\ &= \frac{Nb/a}{(1+b/a)^2 - 2(\gamma-1)Nb/a} \end{aligned}$$

and $M\zeta_0/(1+\theta)^2$ is a function of N , b/a and γ .

The second term in the denominator is generally small compared with the first term, since it is of the same order as ζ_0 ; moreover the range of values of γ for propellants is comparatively small. We may therefore replace γ by a mean value. By choosing $\gamma = 1.25$ the error incurred in the resulting value of ζ_0 does not exceed 2 per cent. for any propellant in general use.

We therefore have

$$\frac{M\zeta_0}{(1+\theta)^2} = \frac{Nb/a}{(1+b/a)^2 - \frac{1}{2}Nb/a}$$

and we thus obtain b/a as a function of N and $M\zeta_0/(1+\theta)^2$.

From equation 8,50, η_1/a is a function of N and b/a ; therefore ξ_1' is also a function of these two quantities. The equation for ζ_1' may be written in the form (using 8,38) :—

$$\frac{M\zeta_1'}{(1+\theta)^2} = \frac{(1-\eta_1/a)(b/a + \eta_1/a)}{\xi_1' b/a} \frac{M\zeta_0}{(1+\theta)^2}$$

and we conclude that $M\zeta_1'/(1+\theta)^2$ can be expressed as a function of N and $M\zeta_0/(1+\theta)^2$.

In Table 8.03 $M\zeta_1'/(1+\theta)^2$ is tabulated in terms of $M\zeta_0/(1+\theta)^2$ and the reciprocal of N , the latter being a more convenient argument for tabulation than N .*

We thus have a means of determining ζ_1' direct from the loading conditions.

It is important to observe that this table is only applicable when ζ' has a true maximum during the burning of the charge. From equations 8,22, 8,42 and 8,50 the condition for a true maximum is

$$N(1-\theta+2\theta f_0) < Mf_0(N+2)$$

which reduces to

$$\gamma M > (1-\theta)/f_0 \quad 8,57$$

The critical value of γM is tabulated in Table 8.02 as a function of θ and ζ_0 .

When $\theta' = 0$ we have from Section 8.10,

$$\zeta_1' = \frac{\zeta_0}{e} \left[1 + \frac{1}{Mn^2\zeta_0} \right]^{Mn^2\zeta_0 + 1}$$

* Elimination of b/a leads to

$$\frac{M\zeta_1'}{(1+\theta)^2} = \frac{1+1/N}{\xi_1'(1+2/N)^2} \left[1 + \frac{3+1/N}{2(1+1/N)} \frac{M\zeta_0}{(1+\theta)^2} \right]$$

But

$$\frac{M\zeta_0}{(1+\theta)^2} = \frac{Mn^2\zeta_0}{1-2(\gamma-1)Mn^2\zeta_0}$$

$$= \frac{Mn^2\zeta_0}{1-\frac{1}{2}Mn^2\zeta_0}$$

when $\gamma = 1.25$.

Hence $Mn^2\zeta_0$ is a function of $M\zeta_0/(1+\theta)^2$ and therefore $M\zeta_1'/(1+\theta)^2$ is a function of $M\zeta_0/(1+\theta)^2$. The entries in Table 8.03 corresponding to $1/N = 0$ have been calculated from these results, so that the table can also be used in this case.

The condition for a true maximum holds when $\theta' = 0$.

8.13. Co-volume correction for maximum pressure

If ζ_1 is the maximum value of ζ , equation 8,39 gives

$$\zeta_1 = \zeta'/(1 - Bc') \quad 8,58$$

where ζ' and c' are calculated for the value of η for which ζ is maximum. Let this value be η_1 , and denote by η_1' , the value of η for which ζ' is maximum.

Then
$$\eta_1 = \eta_1' + \varepsilon$$

where ε is a small quantity of the same order as B .

Hence c' may be calculated for $\eta = \eta_1'$.

Since ζ' is a function of η_1 ,

$$\zeta' = \zeta_1' + \varepsilon d\zeta'/d\eta + 0(\varepsilon^2)$$

where $d\zeta'/d\eta$ is evaluated for $\eta = \eta_1'$. But ζ' is maximum for this value of η ; its derivative is therefore zero.

Hence to the order retained ζ' may be replaced by ζ_1' in equation 8,58.

Since c' is a coefficient of B we evaluate it for $\zeta_0 = 0$. To reduce approximation as much as possible, however, we evaluate only the first term of 8,54 for $\zeta_0 = 0$ and retain the true value of ζ_1' in the second term. Equation 8,50 then gives

$$\eta_1'/a = 1/(N + 2)$$

Substituting in 8,52,

$$\lambda_1 = \frac{N^2}{(N+1)(N+2)} \left[1 - \frac{2N+3}{N+2} \left\{ \frac{N+1}{N+2} \right\}^{N+1} \right]$$

The bracketed term is practically constant for all useful values of N , varying only from 0.25 to 0.264 and back to 0.25 as $1/N$ increases from $-\frac{1}{3}$ through zero to infinity. We choose 0.26 as a suitable value and thus have

$$\lambda_1 = 0.26 N^2/(N+1)(N+2) \quad 8,59$$

When $\theta' = 0$, $\lambda_1 = 0.26$ approximately.

Using 8,54 equation 8,58 now becomes

$$\zeta_1 = \zeta_1' / [1 - B\{\zeta_1' + (1 + \theta)^2 \gamma \lambda_1 / M\}] \quad 8,60$$

The second term in the coefficient of B in equation 8,60 appears to be large when M is small and so to vitiate the approximation. This in fact is not so, since

$$\frac{\lambda_1}{M} = \frac{0.26 N^2}{M(N+1)(N+2)} = \frac{0.26 M}{(M+\theta')(M+2\theta')}$$

and is small for small M except when θ is small. In the latter case the condition 8,57 for maximum pressure is not satisfied when M is small and equation 8,60 is not applicable; the greatest pressure is then at all-burnt.

8.14. Tabular solution for muzzle velocity

From equations 8,47 and 8,48 it is evident that if Φ can be obtained direct from the loading conditions, the muzzle velocity can be determined with only a small amount of calculation.

From equations 8,55 and 8,56,

$$\Phi = \Phi' [1 - Bc_2']^{\gamma-1}$$

and we require Φ' and c_2' directly in terms of the loading conditions.

Dealing first with Φ' , which is given by equation 8,56 as

$$\Phi' = (\xi_2')^{\gamma-1} [1 - \frac{1}{2}(\gamma-1) \eta_2^2 / M]$$

we shall show that it is a function of the three arguments, $(\gamma-1)M$, ζ_0 and θ .

Since $z_0 = \zeta_0$ (equation 8,51) equations 8,23 and 8,24 indicate that $(a-b)/N$ and $(a+b)/N$ are functions of $(\gamma-1)M$, ζ_0 and θ . Hence a/N and b/a are functions of these quantities.

From 8,19 and 8,20, N/M and $(\gamma-1)N$ are functions of $(\gamma-1)M$ and θ .

It is evident from Table 8.04 or equation 8,43 that η_2/M is a function of ζ_0 and θ . Hence η_2/a and $\frac{1}{2}(\gamma-1)\eta_2^2/M$ are functions of $(\gamma-1)M$, ζ_0 and θ .

Since H_2 is a function of η_2/a and b/a it is also a function of these three quantities.

But $\xi_2' = H_2^N$ (from equation 8,33).

Hence $(\xi_2')^{\gamma-1}$ and Φ' are functions of $(\gamma-1)M$, ζ_0 and θ .

These two functions have been calculated for a series of values of the three arguments covering all conditions likely to occur in practice and we have found that it is possible to avoid cumbersome, triple-entry tables by means of good approximations. We shall here consider Φ' and refer to $(\xi_2')^{\gamma-1}$ in the following section.

We have found that $1/\Phi'$ is very nearly linear in $(\gamma-1)M$, so that

$$1/\Phi' = 1 - (\gamma-1)MI + Gy$$

where I is a function of ζ_0 and θ , and Gy is a small correcting term in which G is a function of ζ_0 and θ , and y is a function of $(\gamma-1)M$. The functions I, G and y are tabulated in Table 8.06 and form a very convenient means of determining Φ' ; the value so obtained is generally within 0.1 per cent. of the true value.

The coefficient c_2' is a function of M, γ , ζ_0 and θ and as it is a coefficient of B it is generally sufficiently accurate to calculate it for a mean value of γ and for zero shot-start pressure.

Goldie has found, however, by numerical integration, that the true c_2' as deduced from equation 8,41 is sensitive to ζ_0 when M is large and θ is small ; in fact, an appreciable error in muzzle velocity is incurred by neglecting ζ_0 in these circumstances, despite its being a coefficient of B . He has tabulated a correction to c_2' for $\zeta_0 = 0.1$.

Combining this correction with calculated values of c_2' for $\zeta_0 = 0$, we have found that c_2' can be represented empirically, with sufficient accuracy, by the expression

$$c_2' = \frac{(1 + \theta)^2 + 2.5 M \zeta_0}{\{1 + \theta + M (0.28 - 0.086\theta)\}^2}$$

which is a convenient form for calculation.

To determine the muzzle velocity we therefore obtain $1/\Phi'$ from Table 8.06 ; then

$$\Phi = \Phi' [1 - Bc_2']^{\gamma-1}$$

or approximately,

$$\Phi = \Phi' [1 - (\gamma - 1) Bc_2']$$

$$E = 1 - \Phi [\xi_3 - B]^{1-\gamma}$$

and

$$v_3^2 = 2 FCE/(\gamma - 1) w_1$$

This method is applicable in the case when $\theta' = 0$, the value of Φ' being obtained as indicated above from Table 8.06.

8.15. Tabular solution for all-burnt

A ready method of determining the position of the shot at all-burnt is useful to enable us to ascertain whether the charge is all burnt in the gun. It is also useful in the calculation of the greatest pressure when there is no maximum.

An approximation similar to that indicated in the last section can be used for the reciprocal of $(\xi_2')^{\gamma-1}$; it is

$$(\xi_2')^{1-\gamma} = 1 - (\gamma - 1) MJ - KY$$

where J and K are functions of ζ_0 and θ and Y is a function of $(\gamma - 1) M$. These functions are tabulated in Table 8.05 and values of $(\xi_2')^{\gamma-1}$ obtained thereby are generally within 0.2 per cent. of the true values. This order of accuracy is more than sufficient for all practical purposes.

Having obtained $(\xi_2')^{\gamma-1}$, ξ_2' can be obtained at once from Table 8.07 which gives values of $X^{\gamma-1}$ for useful values of X and γ .

Equation 8,36 gives

$$\xi_2 = \xi_2' (1 - Bc_2') + B$$

from which the position of all-burnt can be deduced.

When there is no true maximum for the pressure, that is, when $\gamma M < (1 - \theta)/f_0$ (see Table 8.02) the greatest pressure is that at all-burnt, and we require ζ_2 .

We have, from 8,45,

$$\zeta_2 = \Phi (\xi_2 - B)^{-\gamma}$$

Hence

$$\zeta_2 = \Phi'/(1 - Bc_2') (\xi_2')^\gamma$$

and ζ_2 can be calculated with the aid of Tables 8.05 and 8.06.

8.16. Muzzle velocity when the charge is not all-burnt in the bore

Cases where $\xi_2 > \xi_3$ are not sufficiently numerous to justify a tabular solution ; we will therefore indicate the method of determining η_3 from the results already obtained.

The first step is to calculate c_3 from equation 8,53. Since it is a coefficient of B an approximate value will suffice. We therefore use the approximations,

$$H_3' = \xi_3^{1/N}$$

and

$$\eta_3'/a = 1 - 1/H_3'$$

We now determine $\log H_3$ from equation 8,34 in the form

$$\log H_3 = [\log \xi_3 - \log (1 - Bc_3)]/N$$

whence, from Table 8.01, η_3/a and therefore η_3 can be determined.

When $\theta' = 0$, c_3 is calculated from 8,53, using the approximation

$$n\eta_3' = \ln \xi_3$$

Then

$$\xi_3' = \xi_3/(1 - Bc_3)$$

and η_3 is obtained by successive approximation from

$$e^{n\eta_3} = \xi_3' (1 + \eta_3/Mn\zeta_0)^{Mn^2\zeta_0}$$

8.17. Pressure-space curve when B is small

When the pressure-space curve is required to a greater degree of accuracy than that obtained by the method of Section 8.10, co-volume corrections are applied to the values of ξ' and ζ' during the burning of the charge. These corrections are given by the equations

$$\xi = \xi' (1 - Bc) \tag{8,34}$$

$$\zeta = \zeta'/(1 - Bc') \tag{8,39}$$

and c and c' are calculated from equations 8,52 ,8,53 and 8,54.

When a maximum pressure exists ζ_1 is obtained from Table 8.03 and equation 8,60.

For the calculation of the corresponding value of ξ_1 a more accurate value of η_1 than that given in Section 8.10 is required. This is obtained as follows :—

Differentiating equation 8,09, putting $d\zeta = 0$ and using equation 8,11,

$$\gamma\eta_1 = M(1 + B\zeta_1) dz_1/d\eta_1$$

But, from equation 8,25,

$$M dz_1/d\eta_1 = (a - b)/N - 2\theta\eta_1/M$$

Hence

$$\eta_1 = \frac{\theta'(a - b)(1 + B\zeta_1)}{\gamma M + 2\theta(1 + B\zeta_1)} \quad 8,61$$

For the calculation of ξ_1 from this value of η_1 we have, from equations 8,25 and 8,61

$$\begin{aligned} z_1 &= z_0 + \frac{\eta_1^2}{M} \left[\frac{a - b}{N\eta_1} - \frac{\theta}{M} \right] \\ &= z_0 + \frac{\eta_1^2}{M} \left[\frac{\gamma}{1 + B\zeta_1} + \frac{\theta}{M} \right] \end{aligned}$$

Hence, from 8,09, neglecting Bz_0 compared with unity,

$$\begin{aligned} \xi_1 &= \zeta_0/\zeta_1 + [\frac{1}{2}(\gamma + 1)M + \theta(1 + B\zeta_1)] \eta_1^2/M^2\zeta_1 \\ &= \frac{\zeta_0}{\zeta_1} + \frac{\eta_1^2}{M} \left[\frac{N + 1}{N\zeta_1} + \frac{B\theta}{M} \right] \end{aligned} \quad 8,62$$

After all-burnt,

$$\zeta(\xi - B)^\gamma = \zeta_2(\xi_2 - B)^\gamma = \Phi \quad 8,45$$

$$= \Phi' [1 - Bc_2']^{\gamma-1} \quad 8,55$$

and ζ is obtained in terms of ξ with the aid of Table 8.06.

8.18. Energy losses

With the exception of loss of heat, the energy losses are allowed for in the "equivalent mass moved," w_1 , as described in Chapter VI. The loss of heat up to the point of maximum pressure is generally small ; in the solution for the pressure-space curve the approximation is such that loss of heat may be neglected ; correction for this loss need, therefore, be applied only to the solution for muzzle velocity.

The correction is applied in this case by reducing the thermodynamic efficiency by a small amount dE . To determine this amount a large number of experimental results were analysed ; the shot-start pressure was deduced, in each case, from the observed maximum pressure and the theoretical efficiency was then calculated by means of equation 8,47. The practical efficiency was calculated from equation 8,48 using the observed muzzle velocity. The difference dE

between these two efficiencies was thus obtained and it was found to depend, as might be expected, on the expansion ratio and the loading density. A number of arguments were tried for the purpose of plotting dE and the most satisfactory was found to be $(\xi_3 - 1) \sqrt{(A/F C)}$. In Fig. 8.01 the results of the analysis are shown and it appears that the correction can be expressed by the linear relation,

$$dE = 0.024 (\xi_3 - 1) \sqrt{(A/F C)} - 0.006$$

for all useful values of the argument.

The experimental results used in the analysis were derived mainly from firings with MD and SC cord, but the empirical values of dE thus deduced have since been used with success with other propellants and shapes.

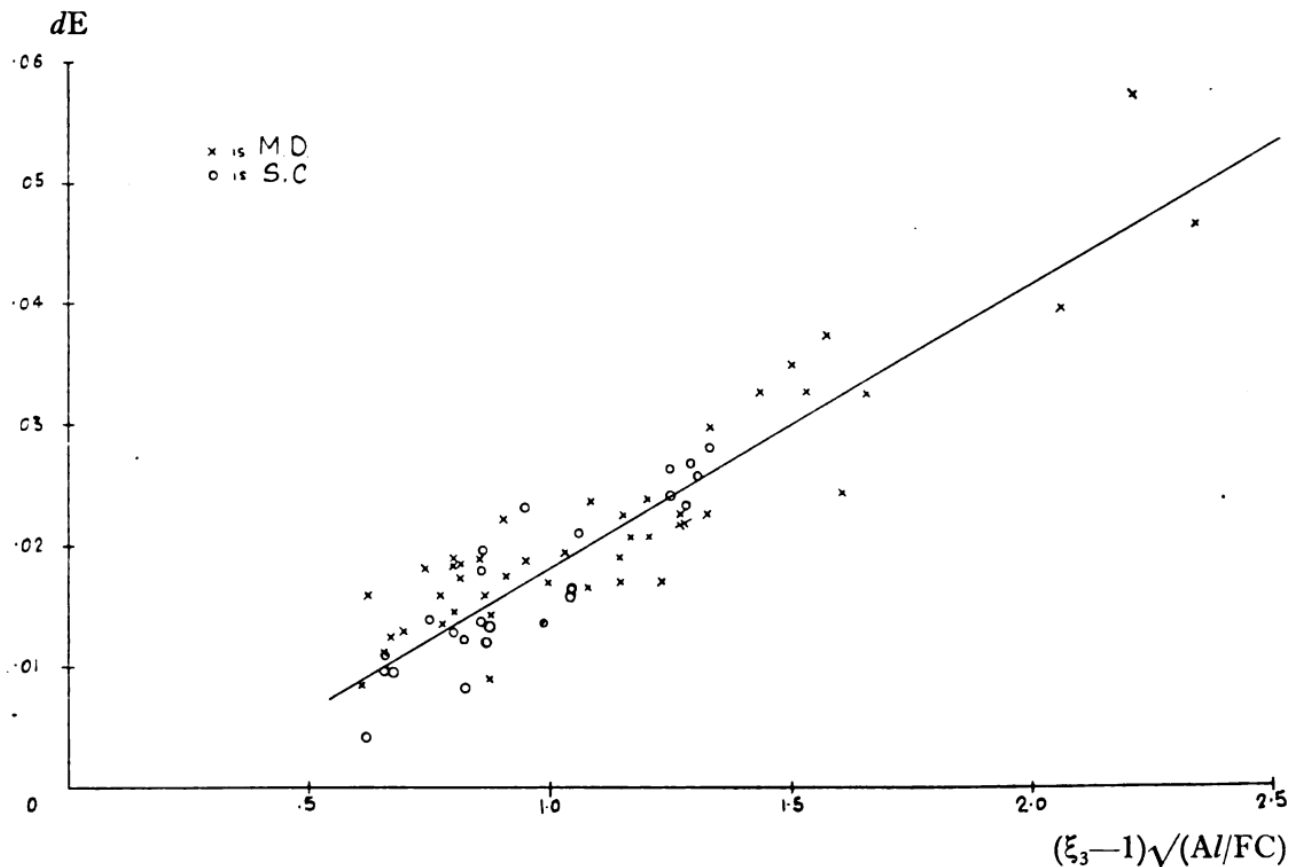

Fig. 8.01

8.19. Practical application of the system

UNITS

All quantities occurring in the tables are dimensionless and are therefore independent of the system of units. The quantities ξ , η , ζ , M and B , however, will only have their true values

H

if the physical quantities on which they depend are expressed in consistent units. Conversion for use with practical units is made by means of the following table, the system of consistent units being the inch, pound and second :—

| Quantity | Consistent Unit | Practical Unit | Factor to Convert Quantities from Practical to Consistent Units |
|----------|--|----------------------------------|---|
| A | sq. ins. | sq. ins. | 1 |
| C | lbs. | lbs. | 1 |
| D | ins. | ins. | 1 |
| F | in.-poundinals per lb.* | in.-tons per lb. | 8.653×10^5 |
| p | poundinals per sq. in.* | tons per sq. in | 8.653×10^5 |
| l | ins. | ins. | 1 |
| β | ins. per sec. per poundinal per sq. in.* | ins. per sec. per ton per sq. in | $1/(8.653 \times 10^5)$ |
| t | secs. | secs. | 1 |
| v | ins. per sec. | ft. per sec. | 12 |
| w | lbs. | lbs. | 1 |
| x | ins. | ins. | 1 |
| w_1 | lbs. | lbs. | 1 |

* The term "poundinal" is used to denote a force which would produce an acceleration of 1 in. per sec. per sec. when acting on a mass of 1 lb., hence the conversion factor in F, p, and β above is $2,240 \times 12 \times 32.19$, i.e., 8.653×10^5 .

Data for some typical propellants are given in practical British units in Table 8.08.

CRUSHER PRESSURES

The crusher gauge (see Chapter XIII) is widely used in routine work to record the **maximum** pressure developed during a firing. The readings obtained from it are, however, of a comparative nature only and the true pressure is appreciably greater. Comparison between piezo-electric gauges (see Chapter XIII) and crusher gauges shows that the true pressure is approximately 20 per cent. greater than the crusher pressure. Moreover, the pressure measured by the gauge in a gun is generally the pressure at the breech end, whereas the pressure calculated by the foregoing method is the mean pressure of the gases. It therefore follows from equation 7,18 that

$$p_1 = 1.2 p_c / (1 + \frac{1}{6} C/w)$$

where p_c is the crusher pressure.

8.20. Collected formulae for use with practical units

PRESSURE-SPACE CURVE

$$Al = K_0 - C/\delta \quad \text{c.in.} \quad (\text{Table 8.08})$$

$$\xi_3 = 1 + x_3/l = (K_3 - C/\delta)/Al$$

$$w_1 = 1.05 w + \frac{1}{3}C \quad \text{lb.}$$

$$\zeta_0 = Alp_0/FC \quad (\text{Table 8.08})$$

$$M = 8.653 \times 10^5 A^2D^2/FC\beta^2w_1 \quad (\text{Table 8.08})$$

$$\theta' = \theta + \frac{1}{2}(\gamma - 1)M \quad (\text{Table 8.08})$$

$$N = M/\theta'$$

$$a - b = N\sqrt{\{(1 + \theta)^2 - 4\theta\zeta_0\}}$$

$$a + b = N\sqrt{\{(1 + \theta)^2 + 2(\gamma - 1)M\zeta_0\}}$$

whence a and b .

η_2 from Table 8.04.

For a series of values of η from 0 to η_2 ,

$$\xi' = H^N \quad (\text{Table 8.01})$$

$$\zeta' = (a - \eta)(b + \eta)/MN\xi'$$

For a series of values of ξ' from ξ_2 to ξ_3

$$\zeta' = \Phi'/(\xi')^\gamma \quad (\text{Table 8.06})$$

For maximum pressure,

$$\eta_1 = (a - b)/(N + 2).$$

Finally,

$$x = l(\xi - 1) \quad \text{in.}$$

$$p = FC\zeta'/Al \quad \text{tons/sq.in.}$$

Notes.

If γM is less than the critical value (Table 8.02)

$$\zeta_1' = \zeta_2'$$

If $\xi_2' > \xi_3$ the charge is not all burnt in the gun.

If $\theta' = 0$

$$1/n = \sqrt{\{(1 + \theta)^2 - 4\theta\zeta_0\}}$$

$$\xi' = e^{\eta\eta} (1 + \eta/Mn\zeta_0)^{-Mn^2\zeta_0}$$

$$\zeta' = (\eta + Mn\zeta_0)/Mn\xi'$$

$$\eta_1 = 1/n.$$

PRESSURE-SPACE CURVE WITH CO-VOLUME CORRECTIONS

During burning,

$$\lambda = \frac{N^2}{(N+1)(N+2)} \left[1 - \{1 + (N+1)\eta/a\} \{1 - \eta/a\}^{N+1} \right]$$

or when $\theta' = 0$

$$\lambda = 1 - [1 + \eta/(1 + \theta)] \exp[-\eta/(1 + \theta)]$$

$$c = \gamma\lambda (1 + \theta)^2/M - \frac{1}{2} (\gamma - 1) \eta^2/M\xi'$$

$$c' = \gamma\lambda (1 + \theta)^2/M + \zeta'$$

$$\xi = \xi' (1 - Bc)$$

$$\zeta = \zeta'/(1 - Bc')$$

For maximum pressure,

$$\lambda_1 = 0.26/(1 + 1/N) (1 + 2/N)$$

$$\zeta_1 = \zeta'_1/[1 - B\{\zeta'_1 + (1 + \theta)^2 \gamma\lambda_1/M\}] \quad (\text{Table 8.03})$$

$$\eta_1 = \frac{\theta' (a - b) (1 + B\zeta_1)}{\gamma M + 2\theta (1 + B\zeta_1)}$$

$$\xi_1 = \frac{\zeta_0}{\zeta_1} + \frac{\eta_1^2}{M} \left[\frac{N+1}{N\zeta_1} + \frac{B\theta}{M} \right]$$

After all-burnt,

$$\zeta = \Phi' [1 - Bc_2']^{\gamma-1} [\xi - B]^{-\gamma} \quad (\text{Tables 8.06 and 8.07})$$

Finally,

$$x = l(\xi - 1) \quad \text{in.}$$

$$p = FC\zeta/Al \quad \text{tons/sq.in.}$$

MAXIMUM PRESSURE, ALL-BURNT, MUZZLE VELOCITY AND MUZZLE PRESSURE.

$$Al = K_0 - C/\delta \quad \text{c.in.} \quad (\text{Table 8.08})$$

$$\xi_3 = 1 + x_3/l = (K_3 - C/\delta)/Al$$

$$w_1 = 1.05 w + \frac{1}{2}C \quad \text{lb.}$$

$$B = C (b - 1/\delta)/Al \quad (\text{Table 8.08})$$

$$\zeta_0 = Al p_0/FC \quad (\text{Table 8.08})$$

$$M = 8.653 \times 10^5 A^2 D^2/FC\beta^2 w_1 \quad (\text{Table 8.08})$$

$$\theta' = \theta + \frac{1}{2}(\gamma - 1) M \quad (\text{Table 8.08})$$

$$1/N = \theta'/M$$

Maximum pressure,

$$\zeta_1 = \zeta_1'/[1 - B \{ \zeta_1' + (1 + \theta)^2 \gamma \lambda_1/M \}] \quad (\text{Table 8.03})$$

$$\lambda_1 = 0.26/(1 + 1/N) (1 + 2/N)$$

$$p_1 = FC\zeta_1/Al \quad \text{tons/sq.in.}$$

If γM is less than the critical value (Table 8.02)

$$\zeta_1 = \zeta_2 = \Phi'/(1 - Bc_2') (\xi_2')^\gamma \quad (\text{Tables 8.05, 8.06, 8.07})$$

All-burnt,

$$c_2' = \frac{(1 + \theta)^2 + 2.5 M \zeta_0}{\{1 + \theta + M (.280 - .086 \theta)\}^2}$$

$$\xi_2 = \xi_2' (1 - Bc_2') + B \quad (\text{Tables 8.05, 8.07})$$

$$x_2 = l (\xi_2 - 1) \quad \text{in.}$$

Muzzle velocity,

$$E = 1 - \Phi' [1 - Bc_2']^{\gamma-1} [\xi_3 - B]^{1-\gamma} \quad (\text{Tables 8.06, 8.07})$$

$$dE = 0.024 (\xi_3 - 1) \sqrt{(Al/FC)} - 0.006$$

$$v_3^2 = \frac{12020F}{\gamma - 1} \frac{C(E - dE)}{w_1} \quad (\text{f/s})^2 \quad (\text{Table 8.08})$$

If $\xi_2 > \xi_3$, proceed as in Section 8.16,

$$v_3 = FC\beta\gamma_3/12AD \quad \text{f/s.} \quad (\text{Table 8.08})$$

Muzzle pressure,

$$\zeta_3 = (1 - E)/(\xi_3 - B)$$

$$p_3 = FC\zeta_3/Al \quad \text{tons/sq. in.}$$

CHAPTER IX

OTHER METHODS FOR A LINEAR LAW OF BURNING

9.01. In the last chapter a general solution of the internal ballistic equations was given for a linear law of burning ; this was followed by special solutions for maximum pressure, muzzle velocity and pressure-space curve for the case when the quantity $(b - 1/\delta)$ is small. In the present chapter we shall consider some other systems of internal ballistics which are based on these equations, or on modified forms of them.

Before giving details of some typical solutions it will be convenient to outline briefly the chief points of difference between the various methods that have been developed from these equations.

9.02. Differences between various methods

These differences can be grouped in four categories :—

- (a) Assumptions regarding the form function.
- (b) Initial conditions.
- (c) Methods of allowing for energy and heat losses.
- (d) Other approximations.

With regard to (a), we have seen in Chapters IV and V that there are two methods of treating the burning of the charge. One, based on Piobert's law, leads to an algebraic expression for the form function in terms of the thickness of grain remaining at any moment ; with this is coupled an expression for the rate of burning down the normal to the surface of the grain. The solution of Chapter VIII is based on this method, the relevant equations being 8,03 and 8,04. The other method, due to Charbonnier, expresses the mass-rate of burning of the charge in terms of the fraction of charge burnt at any moment and can be deduced directly from closed-vessel experiments. This leads to a different form of solution, an example of which is given in Section 9.04. (Sugot's method).

With regard to (b), the generally accepted treatment is to assume, as in the solution of Chapter VIII, that the shot starts to move when the pressure reaches a certain value. In a few methods, however, the shot-start pressure is taken as zero and an empirical adjustment is made to the propellant size or to the rate of burning coefficient or to both. This leads to a simpler solution and generally avoids the use of double-entry tables ; it is not, however, so successful in practice.

With regard to (c), a general survey of the methods of allowing for energy losses was given in Chapters VI and VII. In most systems of internal ballistics the method of modifying the mass of the shot is adopted and differences between the systems occur mainly in the numerical coefficients used ; for example, the fraction of charge weight added to allow for the kinetic energy of the charge varies in different systems from 0.25 to 0.5. Two methods of allowing for loss of heat have already been mentioned, namely, that in which the value of γ is modified, and the Hunt-Hinds method, in which an empirical adjustment, based on a large number of experimental results, is made to the thermodynamic efficiency. In other methods corrections for heat loss are applied directly to the calculated pressure and velocity, while in yet others the rate of burning coefficient or the propellant size is adjusted empirically. In many cases these adjustments also allow for errors due to approximations made in the system.

All such modifications are in the nature of approximations, but in many methods other approximations are made with the object of simplifying the solution of the ballistic equations and facilitating tabulation and numerical calculation.

In many cases approximations are made in the energy equation 8,01. In some the co-volume term $Cz (b - 1/\delta)$ is neglected ; in others z is replaced by a mean value in this term. In a few methods the more drastic approximation is made of neglecting the kinetic energy term, $\frac{1}{2}(\gamma - 1)w_1 v^2$ during the burning of the charge. Such approximations lead to solutions in algebraic form.

One example of a simplifying approximation in the solution was given in Section 8.11, in which coefficients of B were calculated for zero shot-start pressure. This reduced the integral $\int_0^\eta (\eta/\xi') d\eta$ to algebraic form. Other examples are given in the solutions outlined in this chapter.

Approximations in tabulation are generally made to reduce the number of arguments or independent variables in the tables. Finally some methods are designed to give an accurate solution for one shape of grain, namely for that giving constant burning surface, and approximations are introduced for other shapes whose burning surfaces are nearly constant.

9.03. Since the methods to be considered in the following sections are based on the ballistic equations of Chapter VIII, or on modifications thereof, the appropriate formulae for each method can be derived from the solution given in that chapter. To save space and to facilitate comparison, we shall derive the formulae in this way.

To use the special notation of each method would cause great confusion, as different authors denote different quantities by the same symbol. We shall therefore use the notation of the last chapter wherever possible and indicate divergencies from it where necessary.

The order in which the methods are treated is as nearly as possible chronological.

9.04. The method of Sugot

This method was developed in France and was first published in 1913; * it appeared in its final form in 1928.† A complete solution is given using Résal's energy equation and a shot-start pressure ; approximations are subsequently introduced into the solution to facilitate numerical calculation.

Charbonnier's form function is used and the burning of the propellant is therefore represented by equation 5,15 (with $\alpha = 1$) namely

$$dz/dt = Q\phi(z) \quad 9,01$$

Since the constant Q and the function $\phi(z)$ can be determined experimentally for given shape, size and nature of propellant, no theoretical assumptions are made concerning the burning process.

Equation 8,02 can be written

$$w_1 dv/dt = A\phi$$

Hence,
$$v = AV/Qw_1$$

where
$$V = \int_{z_0}^z \frac{dz}{\phi(z)} \quad 9,02$$

* *Mémorial de l'Artillerie Navale*, Vol. VII, 1913.

† G. Sugot, *Balistique Interieure*, 1928.

As we saw in Section 5.12, this function of z and z_0 can be determined directly from closed-vessel experiments.

From 8,06 and 8,08 we obtain

$$\eta^2 = Mw_1 v^2/FC$$

and if we now define M in the form

$$M = A^2/Q^2FCw_1 \quad 9,03$$

equations 8,09, 8,10 and 8,11 still hold, and

$$\eta = MV \quad 9,04$$

If burning proceeds according to Piobert's law (see equation 5,16),

$$Q = (1 + \theta) \beta/D$$

for all shapes commonly used. Hence M as defined above is to M as defined in equation 8,08 in the ratio $1 : (1 + \theta)^2$ while the η defined above is to that of Chapter VIII in the ratio $1 : (1 + \theta)$. The solution, however, is not dependent on Piobert's law and is applicable in all cases where the burning can be represented by equation 9,01.

To obtain the shot-travel in terms of z Sugot chooses as dependent variable

$$y = (\xi - B/k)/(1 - B/k) \quad 9,05$$

where $1/k$ is chosen arbitrarily as a fraction.

From 8,34 we have

$$y = \xi' \left[1 + \frac{B}{k - B} \left\{ 1 - \frac{1}{\xi'} - kc \right\} \right]$$

which is expressed in the form

$$y = \left[1 + \frac{MBE}{k - B} \right] \exp \left[\frac{D}{\frac{1}{2}(\gamma - 1)} \right] \quad 9,06$$

where D and E are functions of z , z_0 and $\frac{1}{2}(\gamma - 1)M$. (No confusion need arise between this function D and the constant D previously used to denote web thickness ; E , moreover, is in no way related to the E used to denote efficiency in Chapter VIII).

Clearly,

$$D = \frac{1}{2}(\gamma - 1) \ln \xi' = \frac{1}{2}(\gamma - 1) \int_0^\eta \frac{d\eta}{Mz - \frac{1}{2}(\gamma - 1)\eta^2} \quad (\text{from Section 8.06})$$

$$= r \int_{z_0}^z \frac{V}{\varphi(z)} \frac{dz}{z - rV^2} \quad 9,07$$

where $r = \frac{1}{2}(\gamma - 1)M$

and

$$E = \frac{1}{M} \left[1 - \frac{1}{\xi'} - kc \right]$$

$$= \frac{1}{M} \int_{1/\xi'}^1 (1 - kz) d(1/\xi') \quad (\text{from equation 8,35})$$

$$= \int_{z_0}^z \frac{V}{\varphi(z)} \frac{1 - kz}{z - rV^2} \frac{dz}{\xi'} \quad 9,08$$

Sugot states that the object of introducing the fraction $1/k$ is to obtain the solution as a sum of two terms of which one is small, powers of which can be neglected in developing formulae for practical use.

The pressure is given by

$$\zeta = \frac{z - rV^2}{(1 - B/k)y - Bz + B/k} \quad 9,09$$

which follows at once from 9,05 and 8,09.

After all-burnt, y is defined as

$$y = (\xi - B)/(1 - B)$$

Denoting by y_2' the value obtained from equation 9,05 when $z = 1$,

$$y_2' = (\xi_2 - B/k)/(1 - B/k)$$

Hence

$$y_2 = \frac{\xi_2 - B}{1 - B} = \frac{(1 - B/k)y_2' - B + B/k}{1 - B}$$

and, from 9,09

$$\zeta_2 = \frac{1 - rV_2^2}{y_2(1 - B)}$$

The pressure and velocity can be deduced from 8,45 and 8,46 :—

$$\zeta = \zeta_2 (y_2/y)^\gamma \quad 9,10$$

$$v^2 = [1 - (1 - rV_2^2) (y_2/y)^{\gamma-1}] 2 FC / (\gamma - 1) w_1 \quad 9,11$$

Maximum pressure

Differentiating 8,09, putting $d\zeta = 0$ and using 8,11, 9,02 and 9,04 leads to

$$\gamma r V_1 / \varphi(z_1) = \frac{1}{2} (\gamma - 1) (1 + B\zeta_1) \quad 9,12$$

This equation, with 9,05 and 9,09, determines the position of the shot and the pressure when the latter has a true maximum.

9.05. Approximations

The function D can be expanded as a power series in r in the form :—

$$D = rW + r^2W' + \dots$$

where
$$W = \int_{z_0}^x \frac{V}{z \varphi(z)} dz, \quad W' = \int_{z_0}^x \frac{V^3}{z^2 \varphi(z)} dz \dots$$

Hence
$$e^{-D} = 1 - rW - r^2U$$

where
$$U = W' - \frac{1}{2} W^2$$

In the case of constant burning surface, for which $\varphi(z) = 1$, $e^{-D} = 1 - rW$ exactly, when $z_0 = 0$. Since z_0 is usually small, the term in r^2 will also be small for practical values of r and the following terms will be negligible for shapes approximating to this type.

Hence, from 9,06

$$y = [1 + rBE/\frac{1}{2}(\gamma - 1)(k - B)][1 - rW - r^2U]^{-2/(\gamma - 1)} \quad 9,13$$

This, combined with 9,09 gives the pressure-space relation.

The functions W and U can be tabulated in terms of z and z_0 ; the function E occurs in a term that is small and need only be evaluated approximately.

Maximum pressure

We write

$$R_1 = \gamma V_1/\frac{1}{2}(\gamma - 1)\varphi(z_1) \quad 9,14$$

Then equation 9,12 becomes

$$rR_1 = 1 + B\zeta_1 \quad 9,15$$

Denoting values of y_1 and ζ_1 by y_1' and ζ_1' when $B = 0$, we have, from 9,13 and 9,09,

$$y_1' = \left[1 - \frac{W_1}{R_1} - \frac{U_1}{R_1^2}\right]^{-2/(\gamma - 1)} \quad 9,16$$

$$\zeta_1' = (z_1 - V_1^2/R_1)/y_1' \quad 9,17$$

Then, neglecting squares and products of the small quantities $B\zeta_1$, BE_1/R_1 and U_1/R_1^2

$$\frac{y_1'}{y_1} = 1 - \frac{BG_1}{k - B} \quad 9,18$$

and

$$\frac{\zeta_1}{\zeta_1'} = 1 - \frac{BF_1}{k - B} \quad 9,19$$

where

$$\frac{1}{2}(\gamma - 1)G_1 = \frac{E_1}{R_1} + \frac{k\zeta_1 W_1}{R_1 - W_1} \quad 9,20$$

and

$$F_1 = G_1 + \frac{1 - kz_1}{y_1'} + \frac{k\zeta_1 V_1^2}{z_1 R_1 - V_1^2} \quad 9,21$$

For given k and γ , the quantities R_1 , y_1' and ζ_1' are functions of z_1 and z_0 only. Moreover, since E_1 occurs only in terms containing B , it can be evaluated for $r = 1/R_1$ and then G_1 and F_1 are also functions of z_1 and z_0 only. Actually tables of y_1' , ζ_1' , G_1 and F_1 have been calculated in terms of R_1 and z_0 .

A method of successive approximation is used to determine ζ_1 and y_1 . First an approximate value of ζ_1 is obtained by means of 9,19, taking $R_1 = 1/r$. Thence a more accurate value of R_1 is obtained from 9,15. The process is now repeated until further approximation is unnecessary.

Muzzle velocity

For unburnt charges the muzzle velocity is obtained by solving 9,13 for z with

$$y = y_3 = 1 + x_3/(1 - B/k) l$$

A first approximation is obtained by neglecting terms in B and r^2 ; the value of z so obtained is used to compute E and U and a second and sufficiently accurate approximation to z is then determined from 9,13. The muzzle velocity is then obtained from

$$v_3^2 = 2 rFC V_3^2/(\gamma - 1) w_1$$

When burning is complete in the bore, the muzzle velocity is obtained from 9,11 in the form

$$v_3^2 = [1 - Y y_3^{1-\gamma}] 2 FC/(\gamma - 1) w_1$$

where

$$Y = (1 - r V_2^2) y_2^{\gamma-1}$$

$$y_3 = 1 + x_3/(1 - B) l$$

and

$$y_2 = \frac{(1 - B/k) y_2' - B + B/k}{1 - B}$$

y_2' is obtained from 9,13 with $z = 1$.

Y is a function which is closely allied to Φ of Section 8.09.

9.06. Numerical tables

Sugot's primary tables relate to maximum pressure, position at all-burnt and muzzle velocity and are calculated for the French "Poudre B," for which

$$F = 9,500 \text{ kg/sq.cm./gm./c.c.}, \quad b = 0.95 \text{ c.c./gm.},$$

$$1/\delta = 0.67 \text{ c.c./gm.}, \quad \gamma = 1.25.$$

French powder is generally used in tubular form and Charbonnier's form function for tube,

$$\varphi(z) = (1 - z)^{0.2}$$

is therefore adopted.

The value of k is chosen as 2.5 and the tables are compiled for a shot-start pressure of 400 kg./sq.cm. With these data it follows from 8,14 that z_0 is determined when Δ (the loading density)* is known; most of Sugot's functions may then be expressed in terms of

* $\Delta = C/K_0$.

r and Δ alone. The tables enable maximum pressure and muzzle velocity (when all-burnt is inside or outside the bore) to be calculated rapidly ; tables are also constructed to facilitate the analysis of experimental firings.

Sugot's secondary tables give differential coefficients for variations of the initial conditions. They are derived by differentiating the expressions for maximum pressure and muzzle velocity and by numerical differentiation of the relevant tabulated functions. The coefficients are denoted by m_x and l_x and are defined by the equations :—

$$\frac{dp_1}{p_1} = m_x \frac{dX}{X} \quad \frac{dv_3}{v_3} = l_x \frac{dX}{X}$$

where X is an initial value.

Coefficients are tabulated for variations in vivacity, Q , force constant, F , weight of shot, weight of charge, chamber capacity and shot-start pressure ; the muzzle-velocity coefficient for variation in shot-travel is also given.

With the aid of these tables ballistics can be calculated for powders with somewhat different characteristics from those assumed in the primary tables and for somewhat different shot-start pressures.

9.07. When this method first appeared in 1913 an approximation was made to facilitate the solution of the equations ; this approximation was subsequently removed and the solution as outlined in Section 9.04 is an exact solution of the equations.

The approximations introduced to facilitate tabulation are good for shapes of grain giving constant or nearly-constant burning surface, but for shapes with larger values of θ notably cord, they give rise to serious errors for all but very small values of M .

Sugot allows for bore resistance by increasing the shot weight by 7 per cent. To obtain agreement with observed pressures he adjusts the rate of burning coefficient Q .

9.08. The method of Crow

This method was first published in 1922 as a development of a method given by F. B. Pidduck in 1918.* The co-volume term is entirely neglected and the kinetic-energy term in the energy equation is neglected during the burning of the charge. The shot-start pressure is taken as zero and allowance is made for band engraving by an empirical reduction of the size of the propellant grain. The form function is based on Piobert's law and equations 8,02, 8,03 and 8,04 hold.

The appropriate formulae can be derived from the solution of Chapter VIII by putting $B = 0$ and $\zeta_0 = 0$ throughout, and $\gamma = 1$ during the burning.

From Section 8.05 we deduce

$$r_i = M(1 - f) \tag{9,22}$$

$$N = M/\theta$$

$$\xi = [1 - r_i/N(1 + \theta)]^{-N} = [(1 + \theta)/(1 + \theta f)]^N \tag{9,23}$$

When $\theta = 0$ this reduces to

$$\xi = e^\eta = e^{M(1-f)} \tag{9,24}$$

* A. D. Crow, Research Dept. Report No. 38.

From equation 8,09,

$$\zeta = z/\xi \quad 9,25$$

The pressure-space curve is given by

$$\zeta = (1 + \theta)^2 (\xi^{1/N} - 1)/\theta \xi^{1+2/N} \quad 9,26$$

When $\theta = 0$ this reduces to

$$\zeta = \ln \xi/M\xi \quad 9,27$$

From 8,50, the maximum pressure occurs when

$$\eta_1 = N(1 + \theta)/(N + 2) = (1 + \theta)/(1 + 2\theta/M) \quad 9,28$$

and the condition for a true maximum is

$$M > 1 - \theta$$

The shot-travel at maximum pressure is given by

$$\xi_1 = [(N + 2)/(N + 1)]^N \quad 9,29$$

and the maximum pressure by

$$\zeta_1 = \frac{(1 + \theta)^2 (N + 1)^{N+1}}{\theta (N + 2)^{N+2}} \quad 9,30$$

When $\theta = 0$,

$$\begin{aligned} \eta_1 &= 1 \\ \xi_1 &= e \\ \zeta_1 &= 1/eM \end{aligned}$$

A good approximation to 9,30 is

$$\zeta_1 = \frac{(1 + \theta)^2}{\theta (eN + 4)} = \frac{(1 + \theta)^2}{eM + 4\theta}$$

This agrees exactly with 9,30 when $\theta = 0$ and differs from 9,30 by less than 1 per cent. for all useful values of θ and M .

Hence the maximum pressure is

$$p_1 = \frac{FC(1 + \theta)^2}{Al(eM + 4\theta)} \quad 9,31$$

All-burnt occurs when

$$\begin{aligned} \eta_2 &= M \\ \xi_2 &= (1 + \theta)^N \quad \text{or} \quad e^M \quad \text{when} \quad \theta = 0 \\ \zeta_2 &= 1/\xi_2 \end{aligned}$$

These values, being derived for $\gamma = 1$, cannot, of course, satisfy equation 8,09 when γ differs from unity. To determine the motion after all-burnt we must therefore use this equation in its differential form, with $z = 1$. Since B is still neglected, the equation takes the form

$$d(\zeta\xi) + (\gamma - 1) \eta d\eta/M = 0$$

which, with 8,11 leads to

$$\gamma\zeta d\xi + \xi d\zeta = 0$$

Hence, for the pressure-space curve after all-burnt we have

$$\zeta\xi^\gamma = \Phi$$

where $\Phi = \zeta_2 \xi_2^\gamma = \xi_2^{\gamma-1} = (1 + \theta)^{N(\gamma-1)}$

When $\theta = 0$ this reduces to

$$\Phi = e^{M(\gamma-1)}$$

The velocity is obtained by integrating from all-burnt ;

$$\eta^2 - \eta_2^2 = 2 M (\zeta_2 \xi_2 - \zeta \xi)/(\gamma - 1)$$

Hence $\eta^2 = M^2 + M\psi(r)$

where $r = \xi/\xi_2$

and $\psi(r) = 2 (1 - r^{1-\gamma})/(\gamma - 1)$

The muzzle velocity is given by

$$v_3^2 = FC [M + \psi(r_3)]/w_1$$

When the charge is not all-burnt in the bore, the muzzle velocity is obtained from equations 9,22 and 9,23 or 9,24.

9.09. This method, which has been in use in the Research Department, Woolwich, for many years, is very simple in application. Owing, however, to the approximations made, more particularly in the energy equation, considerable adjustment is necessary to bring the resulting formulae into agreement with experimental results.

To compensate for neglecting the kinetic-energy term in the energy equation, the force constant F is reduced in value by from 8 to 12 per cent., the actual percentage depending mainly on the nature of the propellant. This constant is further reduced to allow for heat losses by dividing it by the factor $(1 + 1/11d)$ where d is the calibre in inches.

The effect on maximum pressure of neglecting B can be deduced from equation 8,60 while that due to neglecting ζ_0 can be deduced from Table 8.03. For ordinary ballistic conditions the effect of each is to reduce the pressure by 10 to 15 per cent. The effect of neglecting the kinetic-energy term can be deduced from

$$p_1 = \frac{FC (1 + \theta)^2}{Al (eM + 4\theta')} \quad 9,31a$$

which is the form 9,31 takes when the term is retained. For ordinary ballistic conditions the effect is to increase the pressure by 8 to 18 per cent. These three effects, together with the 8 to 12 per cent. reduction in F , combine to give a pressure some 20 to 30 per cent. lower than the true pressure. Equation 9,31 therefore gives an approximation to the pressure as measured by the crusher gauge.

To obtain agreement with observed values, as recorded by the crusher gauge, an empirical correction is applied to the size of propellant grain. Since the size D occurs only in the parameter M in the formula, this correction is in practice applied to this quantity.

The corrections to F and M are retained in the calculation of muzzle velocity and a further empirical correction is then required to obtain agreement between calculated and observed values. This correction has been determined from a large number of experimental results and depends on the maximum pressure, propellant size and capacity ratio of bore to chamber.

It is thus evident that this method can at best be considered to be a convenient means of interpolating for maximum pressure and muzzle velocity between known experimental results ; it is liable to break down when extrapolation is required beyond existing experience. It also fails to give a pressure-space curve in reasonable agreement with experiment.

9.10. The method of Coppock

This method was developed in the Research Department, Woolwich, in 1942* as an extension to Crow's method, with the main object of obtaining a more realistic pressure-space curve. The method was subsequently modified by Lacey and Ruston† and it is this modified version which is considered here.

The complete energy equation is used and the solution is based on equations 8,01 to 8,04. The shot-start pressure is assumed to be zero and band engraving is allowed for by an empirical reduction of the size of propellant grain.

The pressure-space relation is given in the form

$$\xi = 1 + \xi_A - B\xi_B \quad 9,32$$

$$\zeta = \zeta_A / (1 - B\zeta_B) \quad 9,33$$

Comparing these with 8,34 and 8,39 it is evident that

$$\xi_A = \xi' - 1 \quad \xi_B = c\xi'$$

$$\zeta_A = \zeta' \quad \zeta_B = c'$$

and all four functions are independent of B .

Since $x_0 = 0$, these functions can be expressed in terms of two arguments if a mean value of γ is assumed. They were actually tabulated in terms of θ/M and $\eta/(1 + \theta)$, for $\gamma = 1.25$.

After all-burnt, equation 8,45 gives the relation between ζ and ξ ; using 8,30 we obtain

$$\zeta (\xi - B)^\gamma = \zeta_2 (\xi_2 - B)^\gamma = [1 - \frac{1}{2} (\gamma - 1) M] [\xi_2 - B]^{\gamma-1} \quad 9,34$$

ξ_2 is obtained from 9,32, the value of η_2 being M .

For maximum pressure equation 8,61, which is true for all values of B , takes the form

$$\frac{\eta_1}{1 + \theta} = \frac{1 + B\zeta_1}{\gamma + 2(1 + B\zeta_1)\theta/M} \quad 9,35$$

when $x_0 = 0$.

* Armament Research Dept. Ball. Report 82/42.

† Armament Research Dept. Ball. Report 29/45.

Using this in conjunction with 9,33, tables of ζ_1 were calculated in terms of M and B for a series of values of θ , γ being taken as 1.25.

For muzzle velocity, we have from 9,34

$$\Phi = [1 - \frac{1}{2}(\gamma - 1)M] [\xi_2 - B]^{\gamma-1}$$

Hence, from 8,47
$$E = 1 - [1 - \frac{1}{2}(\gamma - 1)M] r_3^{1-\gamma}$$

where
$$r_3 = (\xi_3 - B)/(\xi_2 - B)$$

Hence, from 8,48
$$v_3^2 = 2 FCE/(\gamma - 1) w_1$$

$$= [M + \{1 - \frac{1}{2}(\gamma - 1)M\} \psi(r_3)] FC/w_1 \quad 9,36$$

where
$$\psi(r) = 2(1 - r^{1-\gamma})/(\gamma - 1)$$

and is tabulated in terms of r for $\gamma = 1.25$.

9.11. No approximations have been made in the solution of the equations except to assume a mean value of γ for all propellants. The method of allowing for band resistance by reducing the value of D has been tested against experimental pressure-space curves and has proved to be successful. Since D occurs only in the parameter M in the formulae for pressure, the reducing factor is applied to this quantity in practice. The factor, which is based on true pressures, is found to take the form $j - k/p_1$ where j varies from 0.9 to 1.1 for different propellants and k varies from 3 to 4 tons/sq.in.

In the calculation of muzzle velocity ξ_2 must first be found from 9,32 ; the calculation is therefore not so simple as it appears in 9,36. An empirical correction is required to the calculated value to bring it into agreement with experimental results, the former being usually from 50 to 100 f.s. greater than the latter.

9.12. The method of Goldie

This method was developed in the Armament Research Department in 1944* in an attempt to apply, as closely as possible, the exact solution of the equations to ballistic practice. A shot-start pressure is postulated and the complete energy equation is used.

The pressure-space relation is given by the equations

$$\xi - Bz = \xi' (1 - Bc') \quad 9,37$$

$$\zeta (\xi - Bz) = z_0 (1 - \eta/a) (1 + \eta/b) \quad 9,38$$

The first is equation 8,36 and the second can be derived from equations 8,21 and 8,30. ξ' is obtained from equation 8,33, namely

$$\xi' = H^v$$

* A. W. Goldie Armament Research Dept. Ball. Report 10/45.

and $\log H$ is tabulated as a function of $\eta/(a-b)$ and $4ab/(a-b)^2$. Equations 8,21 and 8,23 give

$$ab = MNz_0$$

$$a - b = N\sqrt{[(1 + \theta)^2 - 4\theta z_0]}$$

The coefficient c' is evaluated for $\zeta_0 = 0$ as in Section 8.11, and $\theta'c'/(1 + \theta)^2$ is tabulated as a function of $\eta/(a-b)$ and θ/M for the mean value, 1.25, of γ .

These tables enable ζ and ξ to be calculated using $\eta/(a-b)$ as a parameter.

Maximum pressure

The formulae used in calculating the maximum pressure are

$$\zeta_1 = z_0(1 - \eta_1/a)(1 + \eta_1/b)/\xi_1' + B\zeta_1 c_1' \quad 9,39$$

which follows at once from 9,37 and 9,38, and

$$\eta_1 = \frac{\theta'(a-b)(1 + B\zeta_1)}{\gamma M + 2\theta(1 + B\zeta_1)} \quad 9,40$$

which is equation 8,61 and is true for all values of B .

Elimination of η_1 from 9,39 and 9,40 gives an equation for ζ_1 but its form is very complicated.

However, if we write $\rho = B\zeta_1$ and expand ζ_1 in the form

$$\zeta_1 = \zeta_1' + \rho \left(\frac{\partial \zeta_1}{\partial \rho} \right)_0 + \frac{1}{2} \rho^2 \left(\frac{\partial^2 \zeta_1}{\partial \rho^2} \right)_0 + \dots \quad 9,41$$

where suffix $_0$ denotes values when $\rho = 0$ we find that the third and subsequent terms are negligible, so that ζ_1 is approximately a linear function of ρ .

Now ρ lies in the range $0 \leq \rho \leq 0.15$ in practice, being usually near 0.1. Thus a convenient method of using the approximate linear relation is to take it through the points $\rho = 0$ and 0.1.

Then
$$\zeta_1 = (\zeta_1)_{.1} + (\rho - 0.1) \psi_1 \quad 9,42$$

where $(\zeta_1)_{.1}$ is the value of ζ_1 when $\rho = 0.1$ and

$$\psi_1 = 10 [(\zeta_1)_{.1} - \zeta_1']$$

The error of 9,42 can be roughly assessed by evaluating the third term of 9,41 for $\rho = 0.05$ and 0.15 when $z_0 = 0$. For zero shot-start,

$$\left(\frac{\partial^2 \zeta_1}{\partial \rho^2} \right)_0 = \frac{(1 + \theta)^2 (\gamma N)^2 (N + 1)^N}{\theta' (N + 2)^{N+3}}$$

and the maximum value of this, remembering that only values of $M \geq (1 - \theta)/\gamma$ are under consideration, is 0.43 at $\theta = 0$ ($\gamma = 1.25$). For $\theta = 1$ the maximum value is 0.165 ($\gamma = 1.25$).

The maximum error of 9,42 is thus about 0.0016 or about 0.3 per cent. of ζ_1 . The average error is much smaller, being of the order of 0.1 per cent.

If the greatest pressure occurs at all-burnt, $\eta_1 = \eta_2$ and η_2 does not contain ρ ; ζ_1 is therefore an exact linear function of ρ . Hence, 9,42 is valid in all cases. From it we calculate ζ_1 directly from the formula

$$\zeta_1 = [(\zeta_1)_{.1} - 0.1 \psi_1] / [1 - B \psi_1] \quad 9,43$$

(This equation may be written

$$\zeta_1 = \zeta_1' / (1 - B \psi_1)$$

and comparing with 8,58 and 8,60 we see that ψ_1 is akin to c_1' although calculated in a different way.)

Numerical tables are available, for a series of values of θ , of $(\zeta_1)_{.1}$ in terms of M' and z_0 , and of ψ_1 in terms of M' only, but with a correction table to allow for the minor effect of z_0 .

The tables were constructed for $\gamma = 1.25$ and other values of γ are allowed for with negligible error by the parameter

$$M' = M [1 + \frac{2}{3} (\gamma - 1.25)]$$

The validity of this can be seen in the case when $B = 0$ and $z_0 = 0$ from equation 9,31a, since M occurs only in the form $M [e + 2 (\gamma - 1)]$. A number of calculations with extreme values of B and z_0 have shown that the approximation is good in all practical cases.

Muzzle velocity

When the charge is all burnt inside the bore the method of Section 8.14 is used, the muzzle velocity being given by the formula

$$v_3^2 = \frac{2 FC}{(\gamma - 1) w_1} \left[1 - \Phi' \left\{ \frac{1 - Bc_2'}{\xi_3 - B} \right\}^{\gamma-1} \right]$$

As mentioned in Section 8.14, the value of c_2' was found to be sufficiently sensitive to ζ_0 to affect the velocity appreciably, in spite of its being a coefficient of B . Special tables were therefore constructed giving c_2' directly in terms of M and θ , with a correction table for z_0 . The correction table gives the difference between the value of c_2' when $z_0 = 0$ and $z_0 = 0.1$ so that linear interpolation or extrapolation can be used to allow for this effect. An empirical relation between c_2' , M , θ and ζ_0 based on these tables was given in Section 8.14.

When the charge is not all burnt in the bore we use equation 8,36 in the form

$$\xi_3 - B = \xi_3' (1 - Bc_3'')$$

where

$$c_3'' = c_3' + (1 - z) / \xi_3'$$

and c_3'' is the appropriate value at the muzzle.

It can easily be proved that at all-burnt $dc_3''/d\eta = 0$ for all values of θ , while $d^2c_3''/d\eta^2 = 0$ for $\theta = 1$.

Now $\theta = 1$ is the usual form coefficient with which unburnt charges occur. Also c_3'' only occurs in the minor term of order B .

Hence we may assume that c_3'' is approximately equal to c_2'' and therefore to c_2' provided η_3 is nearly equal to η_2 , which is true in practice with unburnt charges.

We therefore have

$$\log H_3 = \frac{1}{N} \log \left[\frac{\xi_3 - B}{1 - Bc_2'} \right]$$

and η_3 is obtained from the table of $\log H$.

The velocity is obtained from 8,06 and 8,08 in the form

$$v_3^2 = FC\eta_3^2/Mw_1$$

9.13. In this method the shot-start pressure for a given gun is determined from observed values of maximum pressure with a standard propellant and the rate-of-burning constants of other propellants are adjusted where necessary. Heat losses are allowed for by an empirical adjustment to the calculated muzzle velocity. It is found that the correction varies from 50 to 100 f.s. and depends mainly on the propellant size, the larger values corresponding to smaller sizes.

9.14. We have seen from the examples given here that some form of adjustment is necessary to bring calculated values into agreement with experimental results ; this is equally true of all systems of internal ballistics. In the simpler systems, where a number of simplifying approximations are made, these adjustments must in part compensate for these approximations ; but even in the more general systems in which attempts are made, as far as possible, to allow for all known deviations from theory, adjustments are required to allow for unknown or partly known phenomena. We shall conclude this chapter by considering some of these.

Band engraving and bore resistance

If the pressure at which the shot starts to move is known, the use of a shot-start pressure is probably adequate. Generally, however, the initial pressure is not known and it has to be deduced by analysing a number of experimental firings. Values so deduced may differ, with the same gun and driving band, for different charge weights and propellants. The size-reduction factor, used in some methods instead of shot-start pressure, is found to differ in the same way.

The method of allowing for bore resistance by increasing the equivalent mass moved implies the assumption that bore resistance is proportional to the pressure. We shall see later that experimental evidence on bore resistance is inconclusive ; there is, however, a certain amount of evidence that the resistance decreases slowly or remains nearly constant after band engraving. The assumption may not, therefore, be a good approximation to the facts and may lead to serious discrepancies when the resistance is high.

Variation of γ

In most systems a mean value of γ is used, the mean being calculated for a representative proportional decrease in temperature. Actually γ increases as the temperature falls, so that in less efficient guns a lower mean value than the representative one should be assumed. The error in maximum pressure from this cause is negligible but there may be an appreciable effect on the muzzle velocity.

Rate-of-burning coefficient

The rate-of-burning coefficient β or Q is probably the most uncertain of all the data available. In the first place, the law of burning may not be exactly linear ; a mean value of the coefficient must therefore be adopted. This can be deduced from closed-vessel experiments and it is

generally desirable to have two means, one suitable for high-pressure guns, the other for low pressures. At extremely low pressures the law departs considerably from linear, but such pressures, fortunately, are not encountered in guns except momentarily at the beginning of burning.

Secondly, the solid charge is nearly stationary, during the burning, at the breech end of the gun. Owing to the pressure gradient in the bore, the pressure on the solid propellant is somewhat higher than the mean pressure used in the ballistic equations. This effect can be allowed for by increasing the coefficient by a factor of the form $1 + kC/w_1$, k being about 0.1 when C is less than w_1 .

Lastly there is the effect of erosion of the charge by the flow of the hot gases over the solid propellant. This can also be allowed for by increasing the coefficient, but little is known of this effect in guns and it is generally neglected.

This uncertainty in the rate-of-burning coefficient is probably the chief cause of the variations in the shot-start pressures deduced from the analysis of experimental results.

For these reasons the necessary adjustment is made to the rate-of-burning coefficient in most systems of internal ballistics and subsidiary corrections are applied to γ , to the calculated muzzle velocity, or to the thermodynamic efficiency, to allow for heat losses and variations in the mean value of γ . When these are made the more general systems produce pressure-space or pressure-time curves in good agreement with results obtained from piezo-electric measurements.

CHAPTER X

SOME SOLUTIONS FOR NON-LINEAR RATE OF BURNING

10.01. We have seen in Chapters VIII and IX that the ballistic equations with a linear law of burning admit of solution in finite terms. So far as modern propellants are concerned, the evidence for the linear law is fairly conclusive and the solutions obtained can be used with confidence. Departures from the linear law do occur in the case of single-base and cool, flashless propellants, but the divergencies are generally of such a nature that an equivalent linear law can be used to give sufficiently accurate results.

This is indeed fortunate, since the ballistic equations with the non-linear law (equation 5,04)

$$- Ddf/dt = \beta p^\alpha$$

are generally intractable ; solutions have, however, been obtained with a simplified energy equation and it is the purpose of this Chapter to give a brief account of the mathematical work which has been done in this connection.* We shall conclude with a brief account of some methods of obtaining numerical solutions.

10.02. The reduced ballistic equations

The ballistic equations can be reduced in a manner similar to that used in Section 8.02 ; in fact, the substitutions 8,05 to 8,08 still hold if we replace β by $\beta (Al/FC)^{1-\alpha}$. The ballistic equations then reduce to

$$z = \zeta (\xi - Bz) + \frac{1}{2} (\gamma - 1) \eta^2/M \quad 10,01$$

$$\eta d\eta/d\xi = M\zeta \quad 10,02$$

$$z = (1 - f) (1 + \theta f) \quad 10,03$$

$$\eta df/d\xi = - \zeta^\alpha \quad 10,04$$

where, for M and η we now have

$$M = \frac{A^2 D^2}{FC \beta^2 w_1} \left(\frac{FC}{Al} \right)^{2-2\alpha}$$

and

$$\eta = \frac{v AD}{FC \beta} \left(\frac{FC}{Al} \right)^{1-\alpha}$$

These may be regarded as the generalised forms of M and η when α is not equal to unity. The quantities in the reduced equations are still dimensionless.

The reason why the linear law admits of finite solution is that two variables, ξ and ζ , can be eliminated together between 10,02 and 10,04 (with $\alpha = 1$) and a simple relation between η and f at once follows. No such simple process is possible with the non-linear law, and the variables have to be eliminated in turn.

* For a fuller account see C. A. Clemmow, Phil. Trans. Roy. Soc. A. Vol. 227, 1928.

The variable η can be eliminated quite easily. Differentiating 10,01 and using 10,02 leads to

$$d(z + B\zeta z) = \gamma\zeta d\xi + \xi d\zeta \quad 10,05$$

From 10,02 and 10,04 $\frac{d\eta}{df} = -M\zeta^{1-\alpha}$

and, from 10,04 $\eta = -\zeta^\alpha \frac{d\xi}{df}$

Hence, $\frac{d}{df} \left[\zeta^\alpha \frac{d\xi}{df} \right] = M\zeta^{1-\alpha} \quad 10,06$

The variables z and f are simply related by 10,03 and the elimination of one of them presents no difficulty. Of the remaining variables ξ appears to be the easiest to eliminate in the general case, since a further differentiation of 10,05 leads to one linear relation between its first and second derivatives and a second linear relation is obtained from 10,06. These two equations can be solved for the first and second derivatives of ξ and the variable can then be eliminated by equating the one result to the derivative of the other. This leads to a non-linear differential equation of the third order relating f (or z) and ζ which is generally intractable.

In Sections 10.03 to 10.08 we shall deal with two simplified forms of the energy equation, 10,01 ; in both we shall neglect the co-volume coefficient B and in the second we shall also neglect the kinetic-energy term, as is done in Crow's method with linear law (Section 9.08). Solutions can be obtained for a general value of the form coefficient θ , zero excepted. When θ is zero special and simpler solutions result. We shall deal first with these special solutions and then indicate methods for the general θ .

In Sections 10.09 to 10.15 we shall give a brief account of the use of the differential analyser to obtain numerical solutions for the simplified energy equation and also for the complete energy equation, with the general form function. We shall conclude the chapter with a general step-by-step method of numerical integration.

10.03. Constant burning-surface with the co-volume coefficient neglected

The energy equation 10,05 reduces to

$$dz = \gamma\zeta d\xi + \xi d\zeta = \xi^{1-\gamma} d(\zeta\xi^\gamma) \quad 10,07$$

and, since $z = 1 - f$, equation 10,06 becomes

$$\frac{d}{dz} \left[\zeta^\alpha \frac{d\xi}{dz} \right] = M\zeta^{1-\alpha} \quad 10,08$$

We choose new variables X and Y such that

$$\xi = X^m \quad \zeta\xi^\gamma = (Y/M)^n \quad 10,09$$

wherein the values of m and n have yet to be chosen.

Then $\zeta = (Y/M)^n X^{-\gamma m}$

and $dz = nX^{m(1-\gamma)} Y^{n-1} M^{-n} dY \quad 10,10$

On substituting in equation 10,08 we find that the exponent of M is $n(3 - 2\alpha) - 1$. If, therefore, we choose $n = 1/(3 - 2\alpha)$, M cancels out and the resulting equation is independent thereof.

If we also choose $m = 2n/(\gamma - n)$ we obtain, after a little reduction,

$$XY \frac{d^2X}{dY^2} - \frac{(\gamma - 1)nY}{\gamma - n} \left(\frac{dX}{dY} \right)^2 + \frac{1}{2}(1 + n)X \frac{dX}{dY} = \frac{1}{2}n(\gamma - n)$$

A further slight simplification is obtained by putting

$$Y = Z(1 + n)/n(\gamma - n) \quad 10,11$$

The resulting equation is

$$\frac{2XZ}{1 + n} \frac{d^2X}{dZ^2} - \frac{2n(\gamma - 1)Z}{(1 + n)(\gamma - n)} \left(\frac{dX}{dZ} \right)^2 + X \frac{dX}{dZ} = 1 \quad 10,12$$

with
$$X = \xi^{(\gamma - n)/2n} \quad Z = \frac{n(\gamma - n)}{1 + n} M (\zeta \xi^\gamma)^{1/n}$$

and
$$n = 1/(3 - 2\alpha)$$

The relation between X and Z resulting from 10,12 depends only on the propellant properties γ and α and the initial conditions; it is independent of gun and charge dimensions and is therefore of quite general application. For a given type of propellant the relation between X and Z depends only on the initial conditions; once these are determined the relation between X and Z can be calculated by a step-by-step process, such as Runge's, and can be tabulated.

Two cases here arise, depending on whether a finite shot-start pressure is assumed, or whether this pressure is taken as zero in the analysis and allowed for in some other way (as, for example, in Coppock's method, Section 9.10).

In the first case, $X_0 = 1$ and

$$Z_0 = n(\gamma - n) M \zeta_0^{1/n}/(1 + n)$$

The initial value of dX/dZ is determined by the condition that the shot velocity is initially zero. By substitution in 10,04 we obtain

$$\eta = \frac{2}{X^{1+n(\gamma-1)}} \left[\frac{Z}{\gamma - n} \right]^{1(1+n)} \left[\frac{nM}{1 + n} \right]^{1(1-n)} \frac{dX}{dZ} \quad 10,13$$

and clearly, when $\eta = 0$ the initial value of dX/dZ is zero.

In the second case, $X_0 = 1$ and $Z_0 = 0$. The initial value of dX/dZ is then 1, from 10,12, and 10,13 is also satisfied since $Z_0 = 0$. In this case only a single-entry table of X in terms of Z is needed for a given propellant.

In our further development of this analysis we shall deal only with this case; the extension to the more general case of finite shot-start pressure, although more complicated, presents no analytical difficulty.

When $Z_0 = 0$ a series solution of 10,12 can be developed. By Maclaurin's theorem,

$$X = 1 + X_0' Z + \frac{1}{2} X_0'' Z^2 + \frac{1}{6} X_0''' Z^3 + \dots$$

where the coefficients are the initial values of successive derivatives of X with respect to Z ; these are obtained by successive differentiation of 10,12. The result for the first four terms is,

$$X = 1 + Z - \frac{(1-n)(\gamma+n)Z^2}{2(3+n)(\gamma-n)} \left[1 - \frac{\{(1-n)(7+3n) + (\gamma-1)(7-5n)\}Z}{3(5+n)(\gamma-n)} \right]$$

This series is useful for checking the early stages of the calculation of X in terms of Z .

Maximum pressure

We have

$$\zeta = \left[\frac{(1+n)Z}{n(\gamma-n)M} \right]^n X^{-\gamma m}$$

and ζ is maximum when

$$\frac{dX}{dZ} = \frac{nX}{\gamma m Z} = \frac{\gamma-n}{2\gamma} \frac{X}{Z}$$

In the course of the calculation of X , dX/dZ is also computed. This equation can therefore be solved numerically and the solution depends only on γ and α , that is, on the propellant. If the corresponding values of X and Z are X_1 and Z_1 , we have, for maximum pressure,

$$p_1 = \left[\frac{F^2 C^2 \beta^2 w_1}{A^3 D^2 l} \right]^n G(\gamma, \alpha) \quad 10,14$$

where

$$G(\gamma, \alpha) = \left[\frac{(1+n)Z_1}{n(\gamma-n)} \right]^n \frac{1}{X_1^{\gamma m}}$$

is a function of γ and α only.

If the variation of w_1/l with charge weight is neglected, equation 10,14 gives a monomial law relating maximum pressure and charge weight for the same gun and propellant, of constant size and burning surface, in the form

$$p_1 = kC^{2/(3-2\alpha)}$$

The index is 2 when $\alpha = 1$ and decreases with α , rapidly at first and then more slowly, to unity when $\alpha = \frac{1}{2}$. The departure of the index from the value 2, as determined by experimental firings, should therefore give an indication of departure from the linear law of burning. Unfortunately, the variation of w_1/l with C cannot generally be neglected.

All-burnt

From equation 10,10 we have

$$\begin{aligned} zM^n &= \left[\frac{n+1}{n(\gamma-n)} \right]^n \int_0^{Z^n} X^{-m(\gamma-1)} d(Z^n) \\ &= I(Z) \end{aligned}$$

where $I(Z)$ is a function which can be tabulated for a given propellant from the table of X .

The fraction of charge burnt is therefore determined for any value of Z . At all-burnt,

$$I(Z_2) = M^n$$

The shot-travel to all-burnt is then

$$x_2 = l(\xi_2 - 1) = l(X_2^m - 1)$$

Velocity

From 10,13 we have

$$v = \frac{FC \beta}{AD} \left(\frac{Al}{FC} \right)^{1-\alpha} \eta = \frac{FC \beta}{AD} \left[\frac{A^3 D^2 l}{F^2 C^2 \beta^2 w_1} \right]^{i(1-n)} V(Z)$$

where

$$V(Z) = \frac{2}{X^{1+m(\gamma-1)}} \left[\frac{Z}{\gamma-n} \right]^{i(1+n)} \left[\frac{n}{1+n} \right]^{i(1-n)} \frac{dX}{dZ} \quad 10,15$$

and can be tabulated for a given propellant.

After all-burnt $dx = 0$ and, from 10,07, $\zeta \xi^\gamma$ is constant and therefore equal to $\zeta_2 \xi_2^\gamma$. The energy equation then gives

$$\frac{1}{2} (\gamma - 1) \eta^2 / M = 1 - \zeta \xi = 1 - \left[\frac{(1+n) Z_2}{n (\gamma - n) M} \right]^n \xi^{1-\gamma} \quad 10,16$$

and so the muzzle velocity can be determined.

The solution in this case is thus seen to be based on four numerical tables, $X(Z)$, $I(Z)$, $V(Z)$ and $G(\gamma, \alpha)$. The last is of universal application but the other three are associated with a given propellant, that is, given γ and α . An example of these tables is given in Table 10.01 for NCT. This propellant is in tubular form and therefore burns with constant or nearly-constant burning-surface; its rate-of-burning index is 0.8 and has the greatest divergence from the linear law of all Service propellants; the value of γ is 1.24.

10.04. Constant burning-surface with the simplified energy equation

When the kinetic-energy term in the energy equation is neglected as well as the co-volume coefficient, the equation reduces to

$$z = \zeta \xi \quad 10,17$$

The solution of the ballistic equations for constant burning-surface then becomes a special case of the solution of Section 10.03 for which $\gamma = 1$. It may be summarised as follows:—

Basic equation

$$\frac{2 XZ}{1+n} \frac{d^2X}{dZ^2} + X \frac{dX}{dZ} = 1$$

$$n = 1/(3 - 2\alpha), \quad X = \xi^{1-\alpha}, \quad Z = n(1-n) Mx^{1/n}/(1+n)$$

Series solution

$$X = 1 + Z - \frac{(1+n) Z^2}{2(3+n)} \left[1 - \frac{(7+3n) Z}{3(5+n)} + \dots \right]$$

Maximum pressure occurs when

$$\frac{dX}{dZ} = \frac{1}{2} (1 - n) \frac{X}{Z}$$

$$p_1 = \left[\frac{F^2 C^2 \beta^2 w_1}{A^3 D^2 l} \right]^n G(\alpha)$$

where

$$G(\alpha) = \left[\frac{(1+n) Z_1}{n(1-n)} \right]^n X_1^{-m}$$

$$m = 2n/(1-n) = 1/(1-\alpha)$$

All-burnt occurs when

$$1 = z = \zeta \xi = \left[\frac{(1+n) Z}{n(1-n) M} \right]^n$$

Hence

$$Z_2 = n(1-n) M/(1+n)$$

and

$$x_2 = l(X_2^m - 1)$$

Velocity

$$v = \frac{F C \beta}{AD} \left[\frac{A^3 D^2 l}{F^2 C^2 \beta^2 w_1} \right]^{n(1-\alpha)} V(Z)$$

where

$$V(Z) = \left[\frac{Z}{1-n} \right]^{1(1+n)} \left[\frac{n}{1+n} \right]^{1(1-n)} \frac{dX}{dZ}$$

10.05. General form function and energy equation with $B = 0$

We now consider the case of the more general form function,

$$z = (1-f)(1+\theta f) \tag{10,03}$$

and the energy equation with $B = 0$.

From 10,07 and 10,06

$$dz = \gamma \zeta d\xi + \xi d\zeta$$

$$\frac{d}{df} \left[\zeta^\alpha \frac{d\xi}{df} \right] = M \zeta^{1-\alpha}$$

Write

$$Y = q \zeta \xi^\gamma, \quad Z = qz \tag{10,18}$$

where

$$q = 4\theta/(1+\theta)^2$$

Then

$$dZ = \xi^{1-\gamma} dY \tag{10,19}$$

$$-df = \frac{dz}{\sqrt{\{(1+\theta)^2 - 4\theta z\}}} = \frac{1+\theta}{4\theta} \frac{dZ}{\sqrt{(1-Z)}} \tag{10,20}$$

Eliminating f between 10,06 and 10,20 yields

$$(1 - Z) (\xi'' + \alpha \xi' \zeta'/\zeta) - \frac{1}{2} \xi' = (M/4\theta q) \zeta^{1-2\alpha}$$

where ' and '' denote first and second derivatives with respect to Z .

From 10,19

$$(\gamma - 1) \xi'/\xi = Y''/Y'$$

Hence
and from 10,18,

$$\begin{aligned} \xi''/\xi' &= Y'''/Y'' + (2 - \gamma) Y''/(\gamma - 1) Y' \\ \zeta'/\zeta &= Y'/Y - \gamma \xi'/\xi = Y'/Y - \gamma Y''/(\gamma - 1) Y' \end{aligned}$$

Hence, finally,

$$(1 - Z) \left[\frac{Y'''}{Y''} + (n - 2) \frac{Y''}{Y'} + \alpha \frac{Y'}{Y} \right] - \frac{1}{2} = \frac{Q (Y')^{2-2n}}{Y'' Y^{2\alpha-1}} \quad 10,21$$

where

$$n = \frac{\gamma(1-\alpha)}{\gamma-1} \text{ and } Q = \frac{(\gamma-1)M}{4\theta q^{2-2\alpha}}$$

This equation can be integrated numerically to yield a series of values of Y , Y' and Y'' in terms of Z , for a given propellant (given n and α) and a given value of Q , representing the loading conditions.

The initial conditions are

$$Y_0 = q\zeta_0 \quad Z_0 = qz_0 = q\zeta_0$$

and, from 10,19, $Y' = 1$ and $Y'' = 0$, if a shot-start pressure is used ; if the latter is assumed to be zero, the initial conditions are

$$Y_0 = 0 \quad Z_0 = 0 \quad Y' = 1 \quad Y'' = 0$$

In the latter case the start of the calculation is facilitated by using the following series solution of equation 10,21 :—

$$Y = Z + a_0 Z^{4-2\alpha} \left[1 + a_1 Z + \dots \right] + b_0 Z^{7-4\alpha} \left[1 + \dots \right] + \dots$$

the coefficients being obtained by direct substitution :—

$$a_0 = Q/2 (2 - \alpha)^2 (3 - 2\alpha) \quad a_1 = (3 - 2\alpha)/2 (3 - \alpha)$$

$$b_0 = 2 a_0^2 (2 - \alpha) \{ 3 - 2\alpha - n(2 - \alpha) \} / (5 - 3\alpha)$$

and so on.

It will be observed that Q could be eliminated from equation 10,21 by making the substitution

$$Y = XQ^{\gamma/2n}$$

There is no real advantage in this, however, since Q reappears in the initial value of X' and the calculation cannot be made independent of Q .

The shot-travel is obtained from 10,19,

$$\xi^{\gamma-1} = dY/dZ$$

and the pressure from 10,18,

$$q\zeta = Y/\xi^\gamma = Y/(Y')^{\gamma/(\gamma-1)}$$

The pressure is maximum when

$$\frac{Y'}{\bar{Y}} = \frac{\gamma}{\gamma - 1} \frac{Y''}{\bar{Y}'}$$

and this can be solved numerically from the tabulated values of Y , Y' and Y'' .

At all-burnt, $Z_2 = q$

The velocity can be obtained from the energy equation in the form

$$\begin{aligned} \eta^2 &= 2M (z - \zeta \xi) / (\gamma - 1) \\ &= 2M (Z - Y/Y') / (\gamma - 1) q \end{aligned}$$

Whence

$$v^2 = 2FC (Z - Y/Y') / (\gamma - 1) q w_1$$

After all-burnt,

$$\zeta \xi^\gamma = Y_2 / q$$

and the muzzle velocity is given by

$$v_3^2 = 2 FCE / (\gamma - 1) w_1$$

where

$$E = 1 - Y_2 / q \zeta_3^{\gamma-1}$$

10.06. A similar treatment in the case of $\theta = 0$ leads to the equation

$$\frac{Y'''}{\bar{Y}''} + (n - 2) \frac{Y''}{\bar{Y}'} + \alpha \frac{Y'}{\bar{Y}} = \frac{(\gamma - 1) M (Y')^{2-2n}}{Y'' Y^{2n-1}} \quad 10,22$$

where $Y = \zeta \xi^\gamma$ and the independent variable is z . Since the latter does not occur explicitly, the equation can be solved by treating Y' as a function of Y ; it then reduces to the form 10,12, which yields a general table for a given propellant.

It is interesting to note that the series solution of equation 10,22 with zero shot-start pressure takes the form

$$Y = z \left[1 + \frac{Z}{4 - 2\alpha} + \frac{\{3 - 2\alpha - n(2 - \alpha)\} Z^2}{(5 - 3\alpha)(4 - 2\alpha)} + \dots \right]$$

where

$$Z = \frac{(\gamma - 1) M z^{3-2\alpha}}{(3 - 2\alpha)(2 - \alpha)}$$

so that $MY^{3-2\alpha}$ and Y' ($= \xi^{\gamma-1}$) are functions of Z only, for a given propellant. This result could also be deduced from Section 10.03.

10.07. General form function with simplified energy equation

We now consider the case of the general form function with the simplified energy equation,

$$z = \zeta \xi \quad 10,17$$

Writing

$$\sin^2 \psi = 4\theta z / (1 + \theta)^2 \quad 10,23$$

we have, from 10,20,

$$df = -\sin \psi \, d\psi (1 + \theta) / 2\theta$$

Substituting this in 10,06 and eliminating ζ by means of 10,17 leads to

$$X \frac{d^2 X}{d\psi^2} + (2\alpha - 1) X \frac{dX}{d\psi} \cot \psi = N (\sin \psi)^{4-4\alpha} \quad 10,24$$

where

$$X = \xi^{1-\alpha} \quad \sin^2 \psi = 4\theta z / (1 + \theta)^2$$

and

$$N = (1 - \alpha) M \theta^{2\alpha-3} \left[\frac{1}{2} (1 + \theta) \right]^{4-4\alpha} \quad 10,25$$

This equation is suitable for numerical integration by Runge's method, the initial conditions being $X_0 = 1$, $dX/d\psi = 0$ and $\psi_0 = 0$ if the shot-start pressure is neglected, or

$$\psi_0 = \sin^{-1} [2(\theta \zeta_0)^{\frac{1}{2}} / (1 + \theta)]$$

when a shot-start pressure is assumed.

The pressure can be obtained from 10,17,

$$\zeta = \frac{z}{\xi} = \frac{(1 + \theta)^2 \sin^2 \psi}{4\theta X^{1/(1-\alpha)}}$$

and is maximum when

$$dX/d\psi = 2(1 - \alpha) X \cot \psi$$

Corresponding values of X_1 and ψ_1 can be determined once X and $dX/d\psi$ have been tabulated in terms of ψ and so ζ_1 can be obtained.

The velocity can be obtained from 10,04,

$$\begin{aligned} \eta &= -\zeta^\alpha \, d\xi/df \\ &= \theta^{1-\alpha} \left[\frac{1}{2} (1 + \theta) \sin \psi \right]^{2\alpha-1} (dX/d\psi) / (1 - \alpha) \end{aligned}$$

All-burnt occurs when

$$\psi_2 = \sin^{-1} [2\theta^{\frac{1}{2}} / (1 + \theta)]$$

and the shot-travel to all-burnt is

$$x_2 = l(\xi_2 - 1) = l(X_2^{1/(1-\alpha)} - 1)$$

Tables have been constructed giving X , $dX/d\psi$, $\sin^2 \psi / X^{1/(1-\alpha)}$ and $(\sin \psi)^{2\alpha-1}$ in terms of ψ for a series of values of α and N in the case of zero shot-start pressure.*

A series solution to equation 10,24 can be obtained by substituting

$$X = 1 + \sum a_n \sin^n \psi$$

in the equation and equating coefficients of powers of $\sin \psi$.

* *Loc. cit.*

Writing $r = 3 - 2\alpha$ the equation becomes

$$X \frac{d^2X}{d\psi^2} + (2 - r) X \frac{dX}{d\psi} \cot \psi = N (\sin \psi)^{2r-2}$$

and the solution takes the form.

$$\begin{aligned} X = & 1 + N \sin^{2r} \psi [a_0 + a_2 \sin^2 \psi + \dots] \\ & - N^2 \sin^{4r} \psi [b_0 + b_2 \sin^2 \psi + \dots] \\ & + N^3 \sin^{6r} \psi [c_0 + c_2 \sin^2 \psi + \dots] - \dots \end{aligned}$$

where

$$a_0 = 1/2r (r + 1) \quad a_2 = 2r (r + 2) a_0 / (2r + 2) (r + 3)$$

$$a_4 = (2r + 2) (r + 4) a_2 / (2r + 4) (r + 5)$$

$$b_0 = a_0 / 4r (3r + 1) \quad c_0 = (7r + 3) b_0 / 6r (5r + 1) (r + 1)$$

This solution is useful for calculating X for small values of ψ . The X, ψ curve is very flat when ψ is small, as is evident from the fact that the lowest power of $\sin \psi$ is $2r$; a step-by-step method of calculating would be very prolonged for small values of ψ .

10.08. The chief use of the solutions so far considered is to study the effect on gun ballistics of departures from the linear law of burning. In this connection the solutions with the more general energy equation as given in Sections 10.03 and 10.05 are particularly useful, since the quantities which are neglected, namely B and shot-start pressure, are usually small. The solutions with the more restricted energy equation are not so useful since the kinetic-energy term is by no means small and neglecting it may lead to erroneous conclusions; these solutions have been included mainly for their academic interest.

10.09. Numerical solution for the simplified energy equation with the differential analyser

We shall consider first a solution for the same conditions as in Section 10.07, namely, the general form function and the energy equation with kinetic-energy term and co-volume coefficient neglected.*

Substituting for ζ from 10,17 in 10,06 we obtain

$$\frac{d}{df} \left[\frac{z^\alpha}{\xi^\alpha} \frac{d\xi}{df} \right] = M \frac{z^{1-\alpha}}{\xi^{1-\alpha}} \quad 10,26$$

As in Section 10.07 we write $X = \xi^{1-\alpha}$ and introducing a new variable F such that

$$dF = - z^{-\alpha} df \quad 10,27$$

we obtain

$$X \frac{d^2X}{dF^2} = (1 - \alpha) Mz \quad 10,28$$

and z may be expressed as a function of F by means of 10,27 and 10,03.

* The account given in this and the following section is taken from Ministry of Supply Monograph No. 17.502—*Differential Analyser* by Prof. D. R. Hartree; for further information concerning the machine reference should be made to this paper or to J. Crank's book, *The Differential Analyser* (1947).

For reasons connected with this evaluation of z it is convenient to work in terms of the quantity

$$G = (1 - \alpha) \left[\frac{|\theta|}{1 + \theta} \right]^{1-\alpha} (1 + \theta)^\alpha F \quad 10,29$$

as independent variable.

Equation 10,28 then becomes

$$X \frac{d^2 X}{dG^2} = Kz \quad 10,30$$

where

$$K = \left[\frac{1 + \theta}{|\theta|} \right]^{2-2\alpha} \frac{1}{(1 + \theta)^{2\alpha}} \frac{M}{1 - \alpha} \quad 10,31$$

The relation between z and G can best be found by numerical process (see Section 10.10) and is independent of K ; indeed the relation between $\theta z / (1 + \theta)^2$ and G is independent of both K and θ , and is a function of the index α only. In the evaluation of solutions of 10,30, z can be regarded as a known function of G .

This equation can be handled by the analyser in the form

$$aZ = \int (X + a) dZ - \int z dG \quad 10,32$$

$$X = \int KZ dG$$

where a is a constant.

This requires two integrators and one input table for setting in $\int z dG$ as a function of G . For the first equation a regenerative connection is required of the type described by Amble and Michel.*

An alternative set-up is given by writing $X = \exp Y$ so that $Y = (1 - \alpha) \ln \zeta$

Then the equation becomes

$$\frac{dY}{dG} + \int \frac{dY}{dG} dY = \int \exp(\ln Kz - 2Y) dG \quad 10,33$$

This is convenient as K is supplied as an initial displacement to the integrator which generates the exponential and no gear train is necessary to produce it. Five integrators and one input table are required.

When shot-start pressure is neglected a difficulty arises owing to the flatness of the (X, G) curve initially. This can be overcome by starting with a series solution, but this is troublesome. In practice an iterative process is found to be more satisfactory.

Let $X_0, X_1, X_2 \dots$ be a sequence of functions related by

$$\frac{d^2 X_n}{dG^2} = \frac{Kz}{X_{n-1}}$$

with $X_n = 1$ and $dX_n/dG = 0$ when $G = 0$. Then from any function X_0 (preferably as good an approximation to the solution of 10,30 as may be available) it is possible to evaluate

* O. Amble. *On a principle of connection for Bush integrators.* J.Sc.Inst. Dec. 1946.
J. G. L. Michel. *Extensions in differential analyser technique.* J.Sc.Inst. Oct. 1948.

$X_1, X_2 \dots$ in succession by numerical means and so converge to X . In this way a value of G can be obtained corresponding to a value of X appreciably different from unity, from which a start can be made.

10.10. The relation between z and G .

When $\theta = 0$, $F = z^{1-\alpha}/(1-\alpha)$ and equation 10,28 is used for the numerical solution.

When $\theta > 0$, write

$$w = [\theta(1-f)/(1+\theta)]^{1-\alpha} \quad 10,34$$

Then
$$G = \int_0^w [1 - w^{1/(1-\alpha)}]^{-\alpha} dw \quad 10,35$$

and
$$z = [(1+\theta)^2/\theta] [1 - w^{1/(1-\alpha)}] w^{1/(1-\alpha)} \quad 10,36$$

These equations give the relation between z and G in parametric form. The integral in 10,35 is evaluated numerically and the required numerical relation follows.

When $\theta < 0$ the appropriate substitution, in place of 10,34 is

$$w = [-\theta(1-f)/(1+\theta)]^{1-\alpha}$$

Then
$$G = \int_0^w [1 + w^{1/(1-\alpha)}]^{-\alpha} dw$$

and
$$z = [-(1+\theta)^2/\theta] [1 + w^{1/(1-\alpha)}] w^{1/(1-\alpha)}$$

10.11. Numerical solution of the general equations with the Differential Analyser*

To put the equations in a suitable form for use with the machine, we make the following substitutions :—

$$\zeta = P/B \quad \xi = XB, \quad \eta = VM^{\frac{1}{2}} \quad dX = VdT \quad 10,37$$

Equations 10,01 to 10,04 then become

$$z = P(X - z) + \frac{1}{2}(\gamma - 1)V^2$$

$$dV/dT = P$$

$$z = (1-f)(1+\theta f)$$

$$-df/dT = M^{-1} B^{1-\alpha} P^\alpha$$

These are applied to the machine in the following form :—

$$P = \frac{1}{a} \left[\int (X - z + a) dP + \int Pd(X - z) - (z - Y) \right] \quad 10,38$$

$$V = \int PdT \quad 10,39$$

$$X = \int VdT \quad 10,40$$

* The method described in this section is substantially that which was used in the Cambridge Mathematical Laboratory.

$$Y = \frac{1}{2} (\gamma - 1) V^2 \quad 10,41$$

$$f_0 - f = \int M^{-1} B^{1-\alpha} P^\alpha dT \quad 10,42$$

$$1 - z = \int (1 - \theta + 2\theta f) df \quad 10,43$$

For the first equation, with Amble's regenerative connections, two integrators are needed ; the remaining equations require one integrator each, and in addition, an input table of $M^{-1} B^{1-\alpha} P^\alpha$ is required as a function of P , for equation 10,42.

For the general case, therefore, seven integrators and one input table are required ; when $\theta = 0$ the last integrator is not needed and the number is reduced by one.

The initial values are :—

$$\begin{aligned} X_0 &= 1/B & P_0 &= \zeta_0 B & z_0 &= \zeta_0 / (1 + B\zeta_0) \\ V_0 &= 0 & Y_0 &= 0 & T_0 &= 0 \end{aligned}$$

The quantities T , X , V , P and $(X - z)$ are recorded on counters and f is read from the last integrator.

The elements are finally obtained by calculation as follows :—

$$x = l (BX - 1)$$

$$p = PFC/BAI$$

$$v = V (FC/w_1)^{\dagger}$$

$$t = TBl (w_1/FC)^{\dagger}$$

10.12. The transformation of the ballistic equations considered in the last section has the serious drawback that the accuracy of the ultimate values of x and p depends on the accuracy of B . Now B contains the factor $(b - 1/\delta)$ which is small and cannot be determined with great accuracy ; it follows that the ultimate values of x and p (and t , which is less important) do not attain the accuracy which would be justified by the machine.

To overcome this difficulty and also to avoid an input table or associated gearing dependent on the particular gun-loading conditions, an alternative method may be employed. This is considered in the following sections. Two cases arise ; one is the special case when $\theta = 0$; the other is the more general case of θ not zero.

10.13. Special case, $\theta = 0$

The following substitutions are made in equations 10,01 to 10,04 :—

$$\begin{aligned} \zeta &= P/K & \xi &= XK & \eta &= VK^{1-\alpha} \\ B &= B'K & dX &= VdT \end{aligned} \quad 10,44$$

where

$$K^{2-2\alpha} = M$$

κ

The equations then reduce to

$$\begin{aligned}z &= P (X - B'z) + \frac{1}{2} (\gamma - 1) V^2 \\dV/dT &= P \\dz/dT &= P^\alpha\end{aligned}$$

and are applied to the machine in a form similar to that given in Section 10.11. The only differences are that $X - B'z$ is used instead of $X - z$ and the input table for the last integrator is now P^α as a function of P , which is independent of the loading conditions.

The conversion of z to $B'z$ may be effected by means of an integrator with a constant displacement, or, since B' is a small quantity, it may be done by means of approximate gearing.

The initial values are

$$\begin{aligned}X_0 &= 1/K & P_0 &= K\zeta_0 & z_0 &= \zeta_0/(1 + B\zeta_0) \\V_0 &= 0 & T_0 &= 0\end{aligned}$$

and the elements are finally obtained by calculation as follows :—

$$\begin{aligned}x &= l (KX - 1) \\p &= PFC/KAl \\v &= V (FC/w_1)^{\frac{1}{2}} \\t &= TKl (w_1/FC)^{\frac{1}{2}}\end{aligned}$$

10.14. General case, θ not zero

The following substitutions are made :—

$$\begin{aligned}f &= [(1 + \theta)f' + \theta - 1]/2\theta & z &= Z/q & \zeta &= P/K \\ \xi &= XK/q & \eta &= \frac{1}{2} V (1 + \theta) K^{1-\alpha} & B &= B'K \\ dX &= VdT\end{aligned}$$

10,45

where

$$q = 4\theta/(1 + \theta)^2 \quad \text{and} \quad K^{2-2\alpha} = M/\theta$$

The equations reduce to

$$\begin{aligned}Z &= P (X - B'Z) + \frac{1}{2} (\gamma - 1) V^2 \\dV/dT &= P \\Z &= 1 - (f')^2 \\-df'/dT &= P^\alpha\end{aligned}$$

Except for the small coefficient B' these equations are free from the loading conditions and the form coefficient ; they are, therefore, particularly suitable for a semi-permanent set-up on the machine for a given propellant. They are applied to the machine in a form similar to that given in Section 10.11 ; the arrangement is indicated schematically in Fig. 10.01.

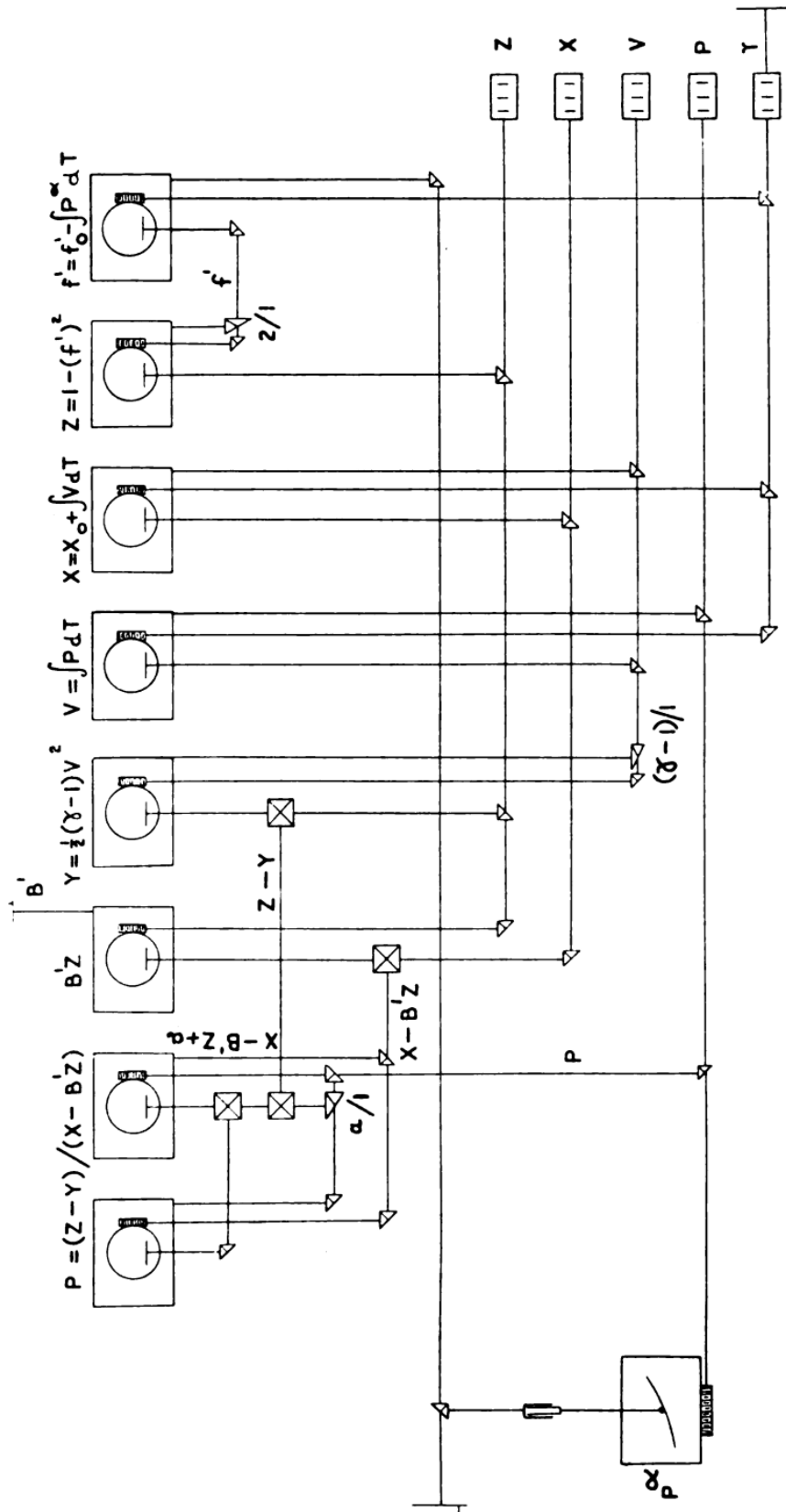

Fig. 10.01

The initial values are

$$X_0 = q/K \quad P_0 = K\zeta_0 \quad Z_0 = q\zeta_0/(1 + B\zeta_0) \quad V_0 = 0 \quad f_0' = (1 - Z_0)^{\frac{1}{2}}$$

All-burnt occurs when $Z = q$.

The elements are obtained by calculation from the out-put of the machine as follows —

$$x = l (XK/q - 1)$$

$$p = PFC/KAl$$

$$v = V (FC/w_1 q)^{\frac{1}{2}}$$

$$t = TKl (w_1/FCq)^{\frac{1}{2}}$$

10.15. After all-burnt

After all-burnt equations 8,45 and 8,46 hold and numerical values can be obtained, once ζ_2 and ξ_2 are known, by direct calculation ; the differential analyser is not, therefore, needed.

10.16. Step-by-step numerical solution

The ballistic equations 10,01 to 10,04 can be solved numerically by a step-by-step process and it has been found from experience that the most convenient independent variable for this purpose is f . Sufficiently accurate results are obtained by working in steps of 0.05 in f up to maximum pressure and 0.10 thereafter.

With this process it is possible, if desired, to introduce a resistance term into equation 10,02. The equation then becomes

$$\eta d\eta/d\xi = M (\zeta - \rho) \tag{10,46}$$

where

$$\rho = RA/FC$$

and R is the resistance to the motion of the projectile per unit cross-sectional area of the bore.

Equation 10,01 then becomes

$$z = \zeta (\xi - Bz) + (\gamma - 1) \left[\frac{1}{2} \eta^2/M + \int \rho d\xi \right] \tag{10,47}$$

Let suffix ₁ denote values of variables at the beginning of a step and suffix ₂, values at the end of the step. Let Δ denote the difference between values at the end and the beginning of a step and let suffix _m denote the arithmetic mean in the step, so that, for example,

$$\Delta\eta = \eta_2 - \eta_1$$

$$\eta_m = \frac{1}{2} (\eta_2 + \eta_1)$$

From 10,46 and 10,04,

$$d\eta = -M (\zeta - \rho) \zeta^{-\alpha} df$$

and in the small interval Δf this becomes

$$\Delta\eta = -M \left[\zeta_m^{1-\alpha} - \rho_m \zeta_m^{-\alpha} \right] \Delta f \tag{10,48}$$

Equation 10,46 similarly leads to

$$\Delta\xi = \eta_m \Delta\eta/M (\zeta_m - \rho_m) \quad 10,49$$

The process consists in estimating $\Delta\zeta$ and so obtaining a tentative value of ζ_m from

$$\zeta_m = \zeta_1 + \frac{1}{2} \Delta\zeta$$

Tentative values of $\Delta\eta$ and $\Delta\xi$ and, therefore, of η_2 and ξ_2 are obtained from 10,48 and 10,49. The value of z_2 is obtained direct from 10,03 since f_2 is known. Then, from 10,47,

$$\zeta_2 = \frac{z_2 - (\gamma - 1) [\frac{1}{2} \eta_2^2/M + \int \rho d\xi]}{\xi_2 - Bz_2}$$

and a value of ζ_2 is determined. Thence a more accurate value of $\Delta\zeta$ is obtained and the tentative values are corrected. The process is repeated as necessary until the estimated and calculated values of $\Delta\zeta$ agree; the step is then solved.

A good estimate of $\Delta\zeta$ is given by

$$\Delta\zeta = - \left[2\theta f_1 + 1 - \theta - \gamma \zeta_1^{1-\alpha} \eta_1 \right] \Delta f / \xi_1$$

which is obtained by differentiating 10,47 with respect to f and neglecting B and ρ . With this estimate it is found, in practice, that only small corrections are needed to obtain complete agreement.

The integral $\int \rho d\xi$ is obtained, of course, in the form $\sum \rho_m \Delta\xi$ where the summation covers all previous steps and includes the step in process of calculation.

The time from beginning to end of a step is given by

$$t_2 - t_1 = \frac{D}{\beta} \left(\frac{Al}{FC} \right)^\alpha \frac{\Delta\xi}{\eta_m} \quad 10,50$$

and the velocity, pressure and shot-travel are obtained from

$$v = \frac{\eta FC \beta}{AD} \left(\frac{Al}{FC} \right)^{1-\alpha}$$

$$p = \zeta FC / Al$$

$$x = l(\xi - 1)$$

The calculation ends at all-burnt, when $f = 0$; after this, values of ζ and η can be obtained in terms of ξ from

$$\zeta (\xi - B)^\gamma = \zeta_2 (\xi_2 - B)^\gamma$$

and

$$\eta^2 = 2M \{ [1 - \zeta (\xi - B)] / (\gamma - 1) - \int \rho d\xi \}$$

where suffix ₂ denotes values at all-burnt.

This method can be used for any value of α and it has sometimes been found to be more convenient than the method given in Chapter VIII for calculating the pressure-space and pressure-time curves when $\alpha = 1$.

CHAPTER XI

SOME APPROXIMATIONS

11.01. This chapter contains a number of approximations which are sometimes used for the solution of special problems. Of these, the first two, dealing respectively with the effect of variations in the temperature of the propellant charge on muzzle velocity, and with composite charges, derive directly from the general treatment given in Chapter VIII. The next section contains an empirical method for estimating the effects of small variations in the loading conditions. Subsequent sections deal with a method for estimating the intermediate charges of howitzers and a purely empirical method of internal ballistic calculations ; the chapter closes with a discussion of the results which may be obtained by applying the principles of similarity to internal ballistic conditions.

11.02. Effect of charge-temperature variations on muzzle velocity

The variation in muzzle velocity due to a change in the temperature of the charge is required in the process of computing a range table. It is a quantity that is not easily determined directly by experiment owing to its smallness for ordinary variations in temperature ; the variation, moreover, is not exactly proportional to the temperature change when the latter is large, so firing at extremes of charge temperature, although giving a measurable difference, does not yield the figure required exactly. Recourse must therefore be had to calculation.

We have seen in Section 5.10 that variation in the temperature of the propellant affects both the rate of burning β and the force constant F ; for 10° F. variation the effect on the former is of the order of 2 per cent. or less and on the latter 0.2 per cent. or less ; representative figures for a number of propellants are given in Table 5.01.

As we are dealing with a small quantity we may approximate when other small quantities occur and we shall also assume a linear law of burning.

Denoting by δ the variation of a quantity due to 10° F. variation in charge temperature, we have, from equation 8,08

$$\frac{\delta M}{M} = -\frac{\delta F}{F} - \frac{2\delta\beta}{\beta}$$

and, from equation 8,48,

$$\frac{2}{v_3} \frac{\delta v_3}{v_3} = \frac{\delta F}{F} + \frac{\delta E}{E}$$

From equation 8,47, we have

$$1 - E = \Phi (\xi_3 - B)^{1-\gamma}$$

Hence

$$-\frac{\delta E}{1-E} = \frac{\delta \Phi}{\Phi}$$

Neglecting the co-volume effect as being of second order, this may be written

$$-\frac{\delta E}{1-E} = \frac{\delta \Phi'}{\Phi'}$$

From Section 8.14 or Table 8.06

$$1/\Phi' = 1 - (\gamma - 1) M I + Gy$$

The effect of the variation in F on $\zeta_0 (=Alp_0/FC)$ is also second-order and therefore I and G are independent of charge temperature, to the order retained.

For our present purpose y can be represented sufficiently accurately by

$$y = 1 - [1 - 2(\gamma - 1)M]^2$$

Hence,

$$\delta\Phi'/(\Phi')^2 = (\gamma - 1) [I - 4G \{1 - 2(\gamma - 1)M\}] \delta M$$

The second term in the square brackets is usually negligible.

Hence finally,

$$\frac{\delta v_3}{v_3} = \frac{\delta F}{2F} + \frac{(\gamma - 1)M(1 - E) \Phi' [I - 4G \{1 - 2(\gamma - 1)M\}]}{E} \left[\frac{\delta F}{2F} + \frac{\delta\beta}{\beta} \right]$$

and, when G is negligible,

$$\frac{\delta v_3}{v_3} = \frac{\delta F}{2F} + \frac{(1 - E)(\Phi' - 1)}{E} \left[\frac{\delta F}{2F} + \frac{\delta\beta}{\beta} \right] \quad 11,01$$

gives the proportional variation in muzzle velocity in terms of the proportional variations in F and β due to a given variation in charge temperature.

11.03. Composite charges

It is necessary, with some howitzer equipments, to use a smaller size of propellant, or a mixture of two sizes, for the lowest charge, to ensure that the charge is all burnt before the projectile reaches the muzzle. Higher charges are made up by adding portions containing propellant of the larger size only, so that a certain quantity of the smaller size is present in all the charges.

The ballistic problem of composite charges is solved by obtaining an approximation to the form function of the same type as 8,03. We shall first obtain an accurate expression for z and then indicate the method of approximating to it.

Let D be the size of the main charge and D/n that of the smaller size ; n is therefore greater than unity ; in practice it is usually about 2. Let C be the total charge weight and let λC be the weight of the portion of smaller size. During the first part of the burning both sizes will burn together until D/n has been burnt off the smallest grain dimension. At this point the smaller size is completely burnt and, if f represents the fraction remaining of the larger size,

$$f_m = 1 - 1/n$$

where suffix m is used to denote this point.

Let f' denote the fraction remaining of the smaller size. At any moment during the first stage of the burning the same thickness is burnt off both sizes, hence

$$D(1 - f) = D(1 - f')/n \quad 11,02$$

The form function during this stage is

$$z = (1 - \lambda)(1 - f)(1 + \theta f) + \lambda(1 - f')(1 + \theta' f') \quad 11,03$$

where θ and θ' are the form coefficients of the larger and smaller sizes respectively. (Usually the same shape is used for both ; θ' is then equal to θ).

Eliminating f' between 11,02 and 11,03 leads to

$$z = (1 - f)(k + qf) \quad 11,04$$

where

$$k = 1 + \lambda(n - 1)(1 - n\theta')$$

$$q = \theta - \lambda(\theta - n^2\theta')$$

After the smaller size is all burnt, the form function becomes

$$\begin{aligned} z &= (1 - \lambda)(1 - f)(1 + \theta f) + \lambda \\ &= 1 - (1 - \theta)(1 - \lambda)f - \theta(1 - \lambda)f^2 \end{aligned} \quad 11,05$$

The expressions 11,04 and 11,05 give the true value of z in the two stages ; at the intermediate point,

$$z_m = [1 + \{\theta + \lambda(n - \theta)\}\{1 - 1/n\}]/n \quad 11,06$$

11.04. We now approximate by assuming a form function

$$z = (1 - f)(1 + \theta_c f)$$

and choose a suitable value of θ_c .

It will be seen at once that the approximation agrees with the true function at the beginning and end of the burning. A fairly good approximation throughout can be obtained by ensuring agreement at the intermediate point. From 11,06, it is evident that this condition is satisfied if

$$\theta_c = \theta + \lambda(n - \theta) \quad 11,07$$

The error of this approximation in the first stage is

$$\lambda(1 - n\theta')(1 - f)(nf - n + 1)$$

which has a maximum value $\lambda(1 - n\theta')/4n$

In the second stage the error is

$$\lambda f(n - 1 - nf)$$

which has a maximum value $\lambda(n - 1)^2/4n$

In practice n is about 2 and λ is never more than $\frac{1}{2}$; it is generally much smaller. The approximation is therefore good.

When $\theta' > 1/n$ the approximation slightly under-estimates the true form function in the first stage and slightly over-estimates it in the second stage.

When $\theta' < 1/n$ the approximation over-estimates the form function in both stages. In this case an even better approximation is obtained by assuming

$$\theta_c = \theta + \lambda(r - \theta)$$

where r is somewhat less than n . The curve of the approximate form function will then intersect the curve of the true function in the second stage at a point between $f = 1 - 1/n$ and zero. The maximum error between this point and $f = 0$ is $\lambda(r - 1)^2/4r$; the error at the point $f = 1 - 1/n$ is of opposite sign and has the value $\lambda(1 - 1/n)(1 - r/n)$.

The curve of the approximate function may or may not intersect the curve of the true function in the first stage. Whether it does or not, the error throughout this stage is less than that at $f = 1 - 1/n$.

The best approximation is obtained by equating the above-mentioned errors in the second stage.

Then

$$\begin{aligned}(r - 1)^2 &= 4r(1 - 1/n)(1 - r/n) \\ &= 4(r - 1)(1 - r/n) + 4(1 - r/n)^2\end{aligned}$$

Hence

$$[r - 1 - 2(1 - r/n)]^2 = 8(1 - r/n)^2$$

which leads to

$$r = \frac{(3 + 2\sqrt{2})n}{n + 2 + 2\sqrt{2}}$$

When n is about 2, this is practically $r = 0.85n$.

Then we have, finally,

$$\theta_c = \theta + \lambda(0.85n - \theta) \quad 11,08$$

When $n = 2$ the maximum error of the approximation is $.075\lambda$ and errors of the same order occur when n lies between 1.5 and 2.5.

The ballistics of the composite charge are now calculated by any of the methods of Chapters VIII to X using this approximate form coefficient.

It may happen that θ_c is greater than unity, particularly if the larger size is in cord form. This would mean that the approximation to z reaches unity and exceeds it before $f = 0$. Although this is physically impossible the solution is not thereby vitiated since the approximate z returns to unity at $f = 0$. When it does occur the excess of the approximate z above unity is always very small.

11.05. Monomial formulae for variations

If one only of the loading conditions in a given gun (for example, the weight of propellant charge) be changed, and the corresponding change in ballistics (for example, the maximum pressure, or muzzle velocity) be measured or calculated, and if the values of the ballistics be plotted against the variable loading condition, both on logarithmic scales, it will frequently be found that the points lie approximately on a straight line, over a considerable range of variation. This indicates that the relation between cause and ballistic effect can be expressed approximately by an expression of the form

$$y = Ax^n \quad 11,09$$

If the interest is centred on the effect δy of a change δx in loading conditions, the differential form of this equation is

$$\delta y/y = n\delta x/x \quad 11,10$$

This property is employed in a method, described in Section 11.06, which is sometimes used for adjusting the weight of intermediate charges in howitzers when firings have been carried out with a high and low charge weight of the same size.

Numerous attempts have been made to determine mean values of n which are applicable to all guns and are sufficiently accurate to determine the effects on ballistics of *small* changes in the loading conditions ; it must be emphasized, however, that the value of n which is applicable to a given gun may be quite seriously different from the mean value, and that any results obtained by the use of any such mean value must be checked, preferably by calculating the differences *ab initio* in the particular case, if a reliable numerical value of the effect is required.

One such set of indices, for use in the estimation of small variations, is due to Messrs. Vickers-Armstrongs Ltd. and is given in the following table :—

MONOMIAL VARIATIONS

| One per cent. increase in :— | Percentage variation in muzzle velocity | Percentage variation in maximum pressure |
|---|---|--|
| Mass of shell. MD., MDT., NCT. | — 0·4 | + 0·6 |
| Mass of charge. MD. | + 0·6 | + 1·6 |
| MDT. | + 0·7 | + 1·8 |
| NCT. | + 0·6 | + 1·6 |
| Chamber capacity. MD. | — 0·25 | — 1·15 |
| MDT. | — 0·25 | — 1·00 |
| NCT. | — 0·25 | — 1·10 |
| Shot travel. MD., MDT., NCT. | + 0·2 | 0 |
| Diameter of cord. MD. | — 0·15 | — 0·85 |
| Thickness of annulus of tube. MDT., NCT. | — 0·3 | — 1·40 |
| Mass of shell at constant pressure (varying charge) | — 0·6 | 0 |

Another set, which is attributed to Pidduck, was used in the Proof and Experimental Establishment for some 30 years for correcting charge-determination firings when the expected results were not exactly achieved ; this set is as follows :—

MONOMIAL VARIATIONS (FOR PROPELLANT PROOF)

| Propellant | Percentage change in charge weight required to give one per cent. change in M.V. $(\delta C/C)/(\delta V/V)$ | Percentage change in maximum pressure due to one per cent. change in charge weight. $(\delta P/P)/(\delta C/C)$ |
|------------|---|--|
| MD. | 1·428 | 1·69 |
| MDT. | 1·0 | 2·0 |
| NCT. | 1·67 | 1·43 |

During the Second World War doubts were cast on the reliability of these figures, especially when they were applied to new types of propellant, of which the ballistics were not well known and the corrections were therefore sometimes large ; as a consequence, mean values of the index are no longer used, but increments are calculated by the standard internal ballistic methods for each individual gun and charge.

Indices corresponding to incremental variations which had been calculated by standard methods for a number of guns and propellants have recently been re-examined with the following results :—

| Propellant | No. of cases examined | $(\delta C/C)/(\delta V/V)$ | | | $(\delta P/P)/(\delta C/C)$ | | |
|--------------------------|-----------------------|-----------------------------|------|--------------|-----------------------------|------|--------------|
| | | Mean | M.D. | Spread | Mean | M.D. | Spread |
| WM. | 12 | 1.54 | 0.16 | 1.33 to 1.81 | 1.79 | 0.23 | 1.37 to 2.23 |
| NH. (Multi-tube) | 10 | 1.56 | 0.13 | 1.30 to 1.88 | 1.70 | 0.17 | 1.44 to 2.02 |
| WMT. | 2 | 1.20 | 0.07 | 1.14 to 1.27 | 2.49 | 0.20 | 2.29 to 2.69 |
| Flashless (slotted tube) | 3 | 1.21 | 0.05 | 1.14 to 1.28 | 2.57 | 0.10 | 2.48 to 2.71 |

These figures give some indication that values for propellants in single-tube or slotted-tube form are materially different from those for other shapes ; they also indicate the extent of the error which can arise from the use of mean values for the index.

11.06. Interpolation of adjusted charge weights for howitzers

An application of the monomial approximation to the relation between charge weight and velocity is used to calculate the adjusted charge weights for intermediate charges of howitzers when the ballistics for two non-adjacent charges of a lot of the *same nature and size of propellant* have been determined at Cordite Proof in the normal manner (see Chapter XIV) ; the method can only be applied when the charge weights for normal propellant of the same nature and size (known for this purpose as the *basic* charge weights) are well determined for the velocities of adjustment of all the charges concerned.

It is assumed that the adjustments to charge weights are small fractions of the charge weights and that they can be deduced from a relation of the form

$$\log C = N \log v - A \quad 11,11$$

where C is the charge weight corresponding to the velocity of adjustment v and N and A are constants.

If C_3 and C_1 are the non-adjacent basic charge weights corresponding to the velocities of adjustment v_3 and v_1 ,

$$N = \log (C_3/C_1)/\log (v_3/v_1) \quad 11,12$$

and the necessary adjustments to the lot charges, ΔC_3 and ΔC_1 are given by

$$\Delta C_3/C_3 = N \Delta v_3/v_3 \text{ and } \Delta C_1/C_1 = N \Delta v_1/v_1 \quad 11,13$$

where Δv_3 and Δv_1 are the divergencies of the lot velocities from the velocities of adjustment for the same charge weights C_3 and C_1 .

This assumes that the value of N for the lot is the same as that for the standard propellant ; the error involved is probably less than that made in the original assumption that equation 11,11 holds.

For the purpose of determining the adjustment ΔC_2 to the middle charge-weight C_2 we assume that N and A for the lot differ from the standard values by ΔN and ΔA .

Then, differentiating 11,11 we have

$$\Delta C/C = N (\Delta v/v) + \Delta N \log v - \Delta A \tag{11,14}$$

The firing data imply that $\Delta C = 0$ when $\Delta v = \Delta v_1$ and $\Delta v = \Delta v_3$, and so ΔN and ΔA are determined. Then ΔC_2 is obtained from 11,14 when $\Delta v = 0$ and $v = v_2$. The result is

$$\Delta C_2 = NC_2 [(\Delta v_1/v_1) \log (v_3/v_2) + (\Delta v_3/v_3) \log (v_2/v_1)]/\log (v_1/v_3) \tag{11,15}$$

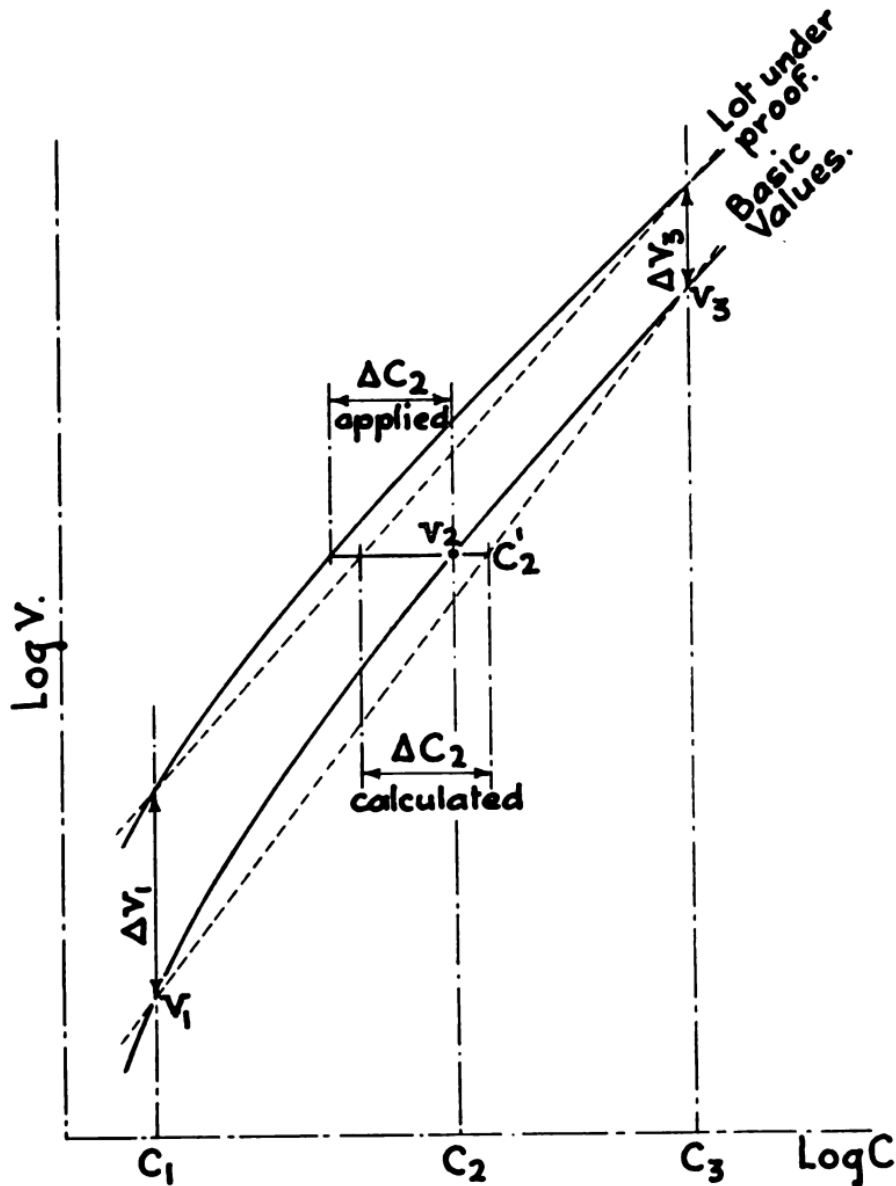

Fig. 11.01

This adjustment is, of course, applied to the established charge-weight C_2 .

This process is illustrated diagrammatically in Fig. 11.01 in which $\log v$ is plotted against $\log C$. The continuous curves indicate the true v, C relation and the dotted straight lines, the monomial relations. It is evident that the process assumes that if the standard and the lot depart from the monomial law, they do so in the same proportion.

As an example in the use of equations 11,11 to 11,15 we take the case of the B.L. 7.2-inch Howitzer, for which well-established charge weights and ballistics are as follows :—

| <i>Charge</i> | <i>Weight</i> | <i>Muzzle Velocity</i> |
|---------------|---------------|------------------------|
| IV | 23 lb. 13 oz. | 1732 f.s. |
| III | 17 lb. 8½ oz. | 1394 f.s. |
| II | 11 lb. 3½ oz. | 1070 f.s. |

At proof of a certain propellant lot the same charge weights for IV and II gave 1783 f.s. and 1099 f.s. and we require the adjusted charge weights for all three charges.

In our notation, $C_3 = 23.81$ lb. $C_2 = 17.51$ lb. $C_1 = 11.22$ lb.
 $v_3 = 1732$ f.s. $v_2 = 1394$ f.s. $v_1 = 1070$ f.s.
 $\Delta v_3 = 51$ f.s. $\Delta v_1 = 29$ f.s.

Equation 11,12 yields $N = 1.566$ and using 11,13 the adjustments to Charges IV and II come to -1.10 lb. and -0.48 lb. respectively.

Equation 11,15 yields $\Delta C_2 = -0.776$ lb. and the adjusted charge weights for the propellant lot are :—

| | |
|------------|----------------------------------|
| Charge IV | 22.71 lb. = 22 lb. 11 oz. 6 dr. |
| Charge III | 16.73 lb. = 16 lb. 11 oz. 11 dr. |
| Charge II | 10.74 lb. = 10 lb. 11 oz. 14 dr. |

11.07. The Le Duc system

The "Le Duc" system of internal ballistic calculations was included in a course of lectures given by Captain Le Duc at the "Ecole d'Application" at Fontainebleau at the beginning of the century and was published, with acknowledgements, in an article on the Theory of Recoil in the "Revue d'Artillerie" in 1904 and 1905.* The method was modified and the constants re-determined for use with American naval propellant, and has since been used as the standard method for the United States Navy.†

The system is almost completely empirical, deriving little support from theory : it depends on assuming a simple algebraic relation between velocity and shot-travel which not only itself approximates to the theoretical relation but of which the derivative is similar to the theoretical relation between pressure and shot-travel. The accuracy of the system has recently been examined in America and in this country‡ and it has been found that, for the purpose of calculating the ballistics with one charge of the propellant for which the constants of the system are established in a gun from the known results with another, it compares favourably with other methods widely used in the two countries.

* J. Challeat. *Theorie des affuts à deformation*. Rev. d'Art. Vol. LXV. pp. 184-186.

† P. R. Alger. *The Le Duc velocity formula*. US. Nav. Inst. Proc. Vol. 37, No. 138, June 1911, pp. 535-540.

G. W. Patterson. *The Le Duc ballistic formulae*. US. Nav. Inst. Proc. Vol. 38, No. 143, September 1912, pp. 885-892.

‡ A. W. Goldie. *A numerical comparison of British and American internal ballistic systems*, ARD. Ball. Report No. 19/46.

The basic assumption of the Le Duc system is that the velocity-space curve for the travel of the projectile up the bore of any given gun can be represented by the hyperbolic equation

$$v = \frac{ax}{b+x} \quad 11,16$$

This curve, which passes through the origin, rises steeply at first, and gradually flattens out, obviously resembles the velocity-space curve in general form, but the equation is not always accurate.

To determine the significance of a it will be noticed that, as x tends to infinity, $x/(b+x)$ tends to unity, and v thus tends to a : thus a is the theoretical velocity of a projectile fired from a gun with the given loading conditions, but of infinite length. Under these conditions, the kinetic energy of the projectile would be $\frac{1}{2} wa^2/g$: but from a consideration of equation 6,10, the energy released by the burning propellant is $FC/(\gamma-1)$; neglecting losses and equating the two energy expressions gives:—

$$FC/(\gamma-1) = \frac{1}{2} wa^2/g$$

or

$$a = \left\{ \frac{2gF}{\gamma-1} \frac{C}{w} \right\}^{\frac{1}{2}}$$

In Alger's discussion,* a factor is introduced containing the loading density to the power $\frac{1}{2}(\gamma-1)$: this is justified on the basis of a definition of the "potential" of the propellant gases as the work done in expanding to infinity from unit density; the treatment is fallacious in that the potential so defined is not a constant, but depends on the temperature or pressure of the gas. The factor is however retained as it is utilised in deriving the constants used with the system; it does not differ greatly from unity; with this factor, the form of the equation found applicable to guns firing American naval pyro powder is†

$$a = 6823 (C/w)^{\frac{1}{2}} (27.68 C/K_0)^{\frac{1}{2}(\gamma-1)} \quad 11,17$$

with $\gamma = 7/6$

C and w are in lbs., K_0 in c.in.

For other propellants the constant term should be modified in the ratio of

$$\{F/(\gamma-1)\}^{\frac{1}{2}}$$

The simplified equation of motion of the projectile gives

$$Ap_s = (w/g) v dv/dx$$

where p_s is the pressure producing acceleration in the shot; this, using equation 11,16 reduces to

$$p_s = \frac{w}{Ag} \frac{a^2 bx}{(b+x)^3}$$

* *Loc. cit.*, p. 536.

† Patterson, *Loc. cit.*

It was found empirically that allowance could be made for pressure gradient in the bore and for frictional and other resistance to the motion of the projectile, by introducing a factor of 1.12 : the expression for the mean gas pressure is thus :—

$$p = \frac{1.12 w}{Ag} \frac{a^2 bx}{(b+x)^3} \quad 11,18$$

giving p in lb./sq.in. when A is in sq.in. and x in ft.

At the point of maximum pressure, dp/dx is zero ; hence, differentiating logarithmically,

$$\frac{1}{x_1} - \frac{3}{b+x_1} = 0$$

or
$$b = 2x_1$$

Thus b is twice the shot travel to the point of maximum pressure. Also, using equation 11,18,

$$p_1 = \frac{4.48 wa^2}{27 Agb} \quad 11,19$$

Again, it is assumed that the shot-travel to maximum pressure is proportional to some function of the *quickness* of the propellant, to the initial air space, and to some power, positive or negative, of the chamber volume and of the weight of the projectile ; that is :—

$$\begin{aligned} b &= q(K_0 - C/\delta) K_0^{\alpha-1} w^{-k} \\ &= q(1 - C/\delta K_0) K_0^\alpha w^{-k} \end{aligned}$$

where q is a constant depending on the composition and ballistic size of the propellant. It has been determined experimentally* that α and k for American pyro powders are both approximately $2/3$: hence

$$b = q(1 - C/\delta K_0) (K_0/w)^{2/3} \quad 11,20$$

The five formulae of the system have been reduced to nomograms for rapid working.

It will be noticed that, in the five formulae which have been derived, the only one that contains any ballistic property of the propellant other than its density is 11,20 where the *quickness* is represented by q ; further, the two quantities measured in routine ballistic firings (muzzle velocity and maximum pressure) each give independent values of b or of q ; these two values will not generally be exactly the same : when ballistic estimates under different conditions are to be based on these values, it is preferable to base velocities on the value of b obtained from velocity and pressures on that obtained from pressure. When firing results are available for a propellant of a given size, q can be determined, and is assumed to be a constant for that size ; when a large number of firing results with different sizes of the same propellant are available, the values of q so deduced are plotted against size ; the best curve through these points can be used for estimating the ballistics of new sizes.

* Patterson : *Loc. cit.*

11.08. Ballistic similitudes

The concepts of ballistic similitude define families of guns with the same pressure-space and velocity-space curves, provided that the scales are suitably adjusted.

(a) GEOMETRIC SIMILARITY. We imagine two guns and their ammunition with the same nature of propellant geometrically similar in all the respects which enter numerically into the equations of Chapter VIII : this implies among other things that the ratio of the propellant sizes of the two guns is equal to that of their calibres and the ratios of the weights of propellant and of projectiles are equal to those of the cube of the calibres. As the propellant constants are the same in both guns, it follows (from equations 8,05 to 8,08) that the following quantities are also the same for both guns : η/v or $AD/FC\beta$; ζ/p or Al/FC ; M .

Further, if the shot-start pressure in the guns is the same, the values of ζ_0 will be the same ; and also, at equal values of ξ the term δE correcting for heat loss (Section 8.18) will also be the same.

Now the treatment of the internal ballistic equations given in Chapter VIII shows that, for the same propellant constants, the values of ζ and η , representing pressure and velocity, at any given value of ξ , representing shot-travel in calibres, depend only on M , ζ_0 , and δE . For the two guns, therefore, provided that shot-travel is expressed in calibres, the pressure-shot-travel and velocity-shot-travel curves are the same : in particular, the two guns have the same maximum pressure and muzzle velocity.

This property was utilised by Messrs. Krupps during the 1939-45 war: the firm were called on to develop guns with calibres of 21, 28 and 80 cms. : in each case, in order to save expense and the wear of the heavier guns, they made a small scale model of the parent gun, the calibres of the model guns being $10\frac{1}{2}$, 15 and 8 cms. respectively, (i.e. to linear scales of $\frac{1}{2}$, $1/1.87$ and $1/10$), and carried out the firings for the determination of propellant size and charge weight in the model guns. They claimed that the deduced propellant and charge gave the correct maximum pressures and muzzle velocities in the parent guns without correction.

It can be shown that, for geometrically similar guns and ammunition, the times taken by the shot to travel to points of equal shot-travel (expressed in calibres), and in particular the total times of travel to the muzzle, are proportional to the calibres of the guns.

(b) DYNAMIC SIMILARITY. We imagine two guns, with calibres d and n_2d respectively, with the same chamber capacities, and the same nature, size and weight of propellant, and examine the conditions that the pressure-space curves for the two guns shall be the same provided that the space is expressed in terms of volume swept by the projectile.

Using the notation of Chapter VIII, and denoting by dashes the values applicable to the gun of which the calibre is n_2d ,

$$A' = n_2^2 A$$

But as K_0 and C are the same for both guns, then from equation 6,11, so too must be Al ; it follows that ζ/p is the same for both guns, and that

$$l' = l/n_2^2$$

For equal swept volumes, Ax ,

$$x' = x/n_2^2$$

and

$$\xi' = 1 + x'/l' = 1 + x/l = \xi$$

Hence, as the pressure-space curve in terms of equal swept volumes is defined by p_0 , ξ and M , if the curves are to be the same for the two guns, $M' = M$.

Then, from 8,08

$$w_1' = n_2^4 w_1$$

and

$$w' + \frac{1}{3} C = n_2^4 (w + \frac{1}{3} C)$$

whence

$$w' = n_2^4 w + \frac{1}{3} C (n_2^4 - 1)$$

For quick approximate working it is sometimes sufficiently accurate to neglect the effect of the inertia of the propellant on the changes in ballistics, and in this case (approximately),

$$w' = n_2^4 w$$

Again, as p_0 and M are the same for the two guns, at equal swept volumes (or ξ), η will be the same, whence, from 8,06

$$v' = v/n_2^2$$

Also, since at equal swept volumes x and v are both inversely proportional to n_2^2 , we have

$$t' = t$$

(c) COMPOUNDED GUNS. We imagine a bundle of n_3^2 identical guns, each of calibre d , with identical projectiles and propellant charges, and that these are fired simultaneously; and we further imagine the bundle of identical guns to be rebuilt into one gun, projectile and charge so that the ballistic elements at any cross-section of the compounded gun are equal to the sum of those of the components. It is then obvious that the relevant dimensions of the compounded gun, in terms of those of the component guns, are

$$\text{Gun : } n_3 d, \quad n_3^2 K_0, \quad n_3^2 K_3, \quad n_3^2 A, \quad x_3$$

$$\text{Propellant : } n_3^2 C, \quad D$$

$$\text{Projectile : } n_3^2 w$$

Denoting by dashes the values applicable to the compounded gun,

$$A'l' = K_0' - C/\delta = n_3^2 Al$$

and

$$l' = l$$

whence, for equal shot-travel (in inches),

$$\xi' = \xi$$

Also, the value of FC/Al is unchanged so that p/ζ is the same.

Again AD/C is unchanged so that v/η is the same and $A^2 D^2 / Cw$ is unchanged so that M is also the same.

It follows that, for the same shot-start pressure, the values of ζ and η in terms of ξ , and of p and v in terms of x , are the same for the compounded and the component guns.

REDUCED DIMENSIONS. It is sometimes convenient, when using these principles, to express the essential dimensions of the gun and ammunition in terms which are either dimension-less or have the dimensions of a density, by dividing by the appropriate power of the calibre. These are known as *reduced* dimensions.

The three transformations outlined in this section can be combined and in the following table they are summarised in their combined form. The calibre ratios n_1 , n_2 and n_3 refer to geometric similarity, dynamic similarity and compounded guns respectively.

BALLISTIC SIMILITUDES

| Quantity (in reduced dimensions where applicable) | Value of quantity in parent gun | Value of quantity in model gun |
|---|---------------------------------------|--|
| Calibre | d | $n_1 n_2 n_3 d$ |
| Chamber capacity | $k = K_0/d^3$ | $k/n_2^3 n_3$ |
| Shot travel | $X = x_3/d$ | $X/n_2^3 n_3$ |
| Projectile weight | $W = w/d^3$ | $W \frac{n_2}{n_3} \left[1 + \frac{C}{3w} \left(1 - \frac{1}{n_2^4} \right) \right]$ |
| Loading Density | $\Delta = C/K_0$ | Δ |
| Propellant size | $j = D/d$ | $j/n_2 n_3$ |
| CURRENT VARIABLES | | |
| Shot-travel | x | $x n_1/n_2^2$ |
| Time | t | $t n_1$ |
| Pressure | p | p |
| Velocity | v | v/n_2^2 |
| SPECIAL VALUES | | |
| Maximum pressure | p_1 | p_1 |
| Muzzle Velocity | v_3 | v_3/n_2^2 |
| Time to muzzle | t_3 | $t_3 n_1$ |

11.09. The most serious limitation to the application of these similitudes is that the pressure and loading density in the parent and model guns must be the same. In particular, it is difficult to ensure that the shot-start pressure is the same in both guns ; since the subsequent pressure in a gun is somewhat sensitive to the shot-start pressure, there is danger of obtaining erroneous results.

In spite of this, however, the similitudes can be used to deduce approximate dimensions of a gun, giving, for the same or a modified value of w/d^3 (a) the same ballistics as the parent gun or (b) the same pressure with a modified velocity. They were, in fact, used in this way in a semi-empirical system of internal-ballistic calculations by the Rheinmetall Borsig A.G. in the period between the two Wars.

SOME APPROXIMATIONS

As an example of their use, we take the case of a 20.3-cm. gun which has the following dimensions and gives the following ballistics :—

| | |
|-------------------|-----------------|
| Chamber capacity | 70,300 c.c. |
| Shot travel | 964.5 cm. |
| Projectile weight | 122 kg. |
| Charge weight | 50 kg. |
| Propellant size | 0.35 cm. |
| Muzzle velocity | 925 m.s. |
| Maximum pressure | 3200 kg/sq. cm. |

From these data we can at once deduce that a gun of calibre d cm. will give the same ballistics with the same type of propellant provided the following dimensions obtain :—

| | | |
|-------------------|-----------------------------|--------------------|
| Chamber capacity | $= kd^3$ | $= 8.4 d^3$ c.c. |
| Shot travel | $= Xd$ | $= 47.5 d$ cm. |
| Projectile weight | $= Wd^3$ | $= 0.0146 d^3$ kg. |
| Charge weight | $= K_0\Delta = k\Delta d^3$ | $= 0.0060 d^3$ kg. |
| Propellant size | $= jd$ | $= 0.0172 d$ cm. |

If the model gun is to have a velocity of 1100 m.s. and a w/d^3 value of 0.0135 (for example), we have from the table,

$$925/n_2^2 = 1,100$$

$$0.0146 \frac{n_2}{n_3} \left[1 + \frac{C}{3w} \left\{ 1 - \frac{1}{n_2^4} \right\} \right] = 0.0135$$

giving $n_2 = 0.917$; $n_3 = 0.935$.

The dimensions to give the same pressure with the same type of propellant for a gun of d cm. calibre will be :—

| | | |
|-------------------|--------------------------|--------------------|
| Chamber capacity | $= kd^3/n_2^3n_3$ | $= 11.7 d^3$ c.c. |
| Shot travel | $= Xd/n_2^3n_3$ | $= 66 d$ cm. |
| Projectile weight | | $= 0.0135 d^3$ kg. |
| Charge weight | $= k\Delta d^3/n_2^3n_3$ | $= 0.0083 d^3$ kg. |
| Propellant size | $= jd/n_2n_3$ | $= 0.020 d$ cm. |

CHAPTER XII

PROJECTILE VELOCITY MEASUREMENT

12.01. A large number of methods have been developed and many used for the measurement of projectile velocity, but here only the Boulengé Chronograph and the Photo-electric Counter Chronometer (P.C.C.) systems are described. These are standard methods and are far more important than any of the other methods. The Boulengé Chronograph was invented as long ago as 1874 and it has been widely, almost universally, used since then as the standard method for projectile velocity measurement. In the United Kingdom it is still widely used but is giving place to the P.C.C. system which has been developed in the past 10 years by the Armament Research Establishment of the Ministry of Supply, and in which advantage is taken of modern electronic methods to improve accuracy and to make operation easier and less dependent upon the skill of the operator.

Of the special problems of projectile velocity measurement, first and foremost is the high accuracy which is demanded. This is usually specified as an accuracy of 1 part in 1000, although higher degrees of precision are really required for studying round to round variations in muzzle velocity and for determining the retardation of the projectile in flight. The magnitude of the velocity, which implies the measurement of a short time interval to this high degree of accuracy, is itself a difficulty. Other factors which have to be considered in instrument design are the disturbing effects of blast from the gun and of ground shock. Finally, the measurements are required to be made rapidly and as a routine operation.

Nearly all methods of measuring projectile velocity consist in measuring the time taken by the projectile to pass between two points on the trajectory at a known distance apart, and deducing the velocity from this distance and the measured time. Because of the magnitude of the velocity, the tendency is to make the trajectory distance large. The velocity of the projectile is not, however, constant on account of the retardation due to air resistance. In the extreme case of a small projectile travelling at high velocity, the drop in velocity over a distance of only 10 feet will be nearly 1 per cent. Since the two methods described in this chapter use trajectory base lengths of at least 90 feet, it is clearly advisable to consider the significance of the deduced, or *observed* velocity. It is found that under normal conditions and for normal purposes the usual assumption, that the observed velocity corresponds to the velocity of the projectile when it is equidistant from the two points on the trajectory, is justified.

12.02. The Boulengé Chronograph

The Boulengé Chronograph was invented by Le Boulengé of the Belgian Army and for well over half a century remained the generally accepted method for the measurement of projectile velocities. The length of this period is an indication of the merits of this simple yet accurate instrument for measuring time intervals of about 1/10 second.

The Chronograph measures projectile velocities by measuring the time taken by the projectile to pass between two wire screens set up in the trajectory at a known distance apart. The wire screens form parts of electric circuits and the passage of the projectile by rupturing the wires breaks these circuits.

The time is measured by observing the distance through which a body falls freely under gravity in the time interval to be measured. It is not difficult to start a body falling at the beginning of the time interval if this is defined by the breaking of an electric circuit; the body can be supported by an electro-magnet and dropped when the current through the magnet is

interrupted. It is more difficult to determine the distance through which the body has fallen at the end of the time interval. In the Boulengé Chronograph this difficulty is solved in an ingenious manner ; the end of the time interval is also defined by the breaking of an electric circuit, and the breaking of this circuit is used to drop a second body which after falling a certain distance strikes a trigger. This trigger releases a spring-loaded knife, which springs out laterally and makes a mark on the first body which is still falling freely. The position of this mark determines the distance through which the body has fallen in the total time interval made up of the time interval to be measured and the time for the second body to fall and the knife mechanism to function. This inevitable delay in making the distance recording mark can be determined and allowed for, and is actually an advantage for it increases the sensitivity of the method.

The sensitivity of the measurement is determined by the velocity of the body when it is struck by the knife, since the increment in distance corresponding to an increment in time is this time increment multiplied by the velocity. The velocity is proportional to the total time of falling and thus a known addition to the time interval to be measured will increase the sensitivity. In the Boulengé Chronograph the order of the time interval measured is 0.1 second and the time for the knife to function is 0.15 second ; the latter therefore increases the sensitivity by a factor of 2.5.

12.03. In its usual form and as shown in Figure 12.01 the actual instrument consists of two electro-magnets supported on either side of a substantial vertical pillar of brass. One magnet is rigidly fixed near the top of the pillar ; the other can be varied in height and is normally about 11 inches lower than the first. The magnets have separate circuits, and each circuit passes through a wire screen which is placed in the line of fire and broken by the passage of the projectile. The screen in circuit with the upper magnet is the one nearer to the gun and is known as the *near* screen. The lower magnet is in circuit with the more distant or *far* screen. Each magnet supports a rod ; that supported by the upper magnet is about 22 inches, and the other about 5 inches in length. They are referred to as the *long* and *short* rods respectively. On breaking the magnet circuits the long rod has an uninterrupted descent into a deep recess in the pedestal of the instrument ; the short rod on the other hand, after descending about 4 inches, falls upon a trigger and releases a knife which springs out laterally to cut a notch on the long rod while it is falling.

The pedestal on which the instrument is mounted is a solid pillar of concrete sunk well into the ground. Contact between the pillar and the floor or walls of the building in which it is situated is avoided so that the rods are not liable to be shaken down by any local disturbance or vibration. The pedestal is situated at a sufficient distance from the gun position to prevent either rod being shaken down by the ground shock caused by firing the gun.

Each rod consists of a phosphor bronze tube bearing at one end a pole piece of soft iron, and at the other a metal bob. The centres of gravity of the rods are thus kept as low as possible. The cuts on the long rod are taken upon a renewable sheath of plated copper tube, which is crimped to the rod sufficiently tightly to prevent slipping.

The average velocity of the projectile between the two screens is recorded in terms of the distance fallen by the long rod from its initial position up to the point where it is cut by the knife. The initial position is marked by a *zero* cut obtained by releasing the knife by hand while the long rod is still hanging.

If the rods are released simultaneously, as would happen were the velocity infinite, a cut will be made about 4 inches above the zero mark, and the distance between these two cuts will

be that fallen by the long rod while the short rod is falling and operating the knife mechanism. This time interval can be controlled by raising or lowering the short rod magnet. It is known as the *disjunction time* and a value of 0.15 second has been chosen for the graduation of measuring scales which give a direct reading of velocity.

For reading the position of the cut on the long rod two types of scale and reader are in use. In the older type (Figure 12.02) the scale is graduated in velocities for one given screen distance, and in inches. It is applied to the long rod by inserting a hinged conical spigot at one end of it into a corresponding recess formed in the bob of the rod. The more modern type of scale and reader (Figure 12.03) can be used for a pair of rods simultaneously. It will give the usual mid-screen, or observed, velocity, and also contains a device for correcting this approximately to give the muzzle velocity when flat-headed projectiles are being used.

The adjustment of the instrument before use consists of positioning the short rod magnet so that the disjunction time is exactly 0.15 second. In this time the distance fallen from rest by the long rod is 4.345 inches. A line known as the *disjunction line* is circumscribed on the long rod at this distance above zero, and the short rod magnet is raised or lowered until the cut when both rods are released simultaneously is exactly on this line.

The device for breaking both circuits simultaneously is known as the *disjuncter*. This is shown in Figure 12.04 and consists of an electro-magnet with an L-shaped pivoted armature upon the outer arm of which are mounted two weighted spring contacts. The movement of the outer arm of the armature is limited by a heavy stop. The circuits from the screens are completed through these spring contacts so that when the armature is attracted by energizing the magnet, and suddenly checked by impinging upon the stop, the spring contacts continue to move forward breaking both circuits simultaneously. A reversing switch is provided so that the two spring contacts can be interchanged between the *near* and *far* screen circuits, thus checking that they do actually break simultaneously.

12.04. Accuracy of the Boulengé chronograph

The Boulengé Chronograph does not function exactly in the ideal manner described above. The divergences are small, but are potential sources of inaccuracy. The force exerted by the magnets upon the rods does not change instantaneously to zero when the magnet circuits are broken, but decreases at a finite rate which depends upon the formation of eddy currents in adjacent metal, the possible presence of shorted turns in the magnet coils and the capacity and leakage resistance of the cables connecting the instrument to the screens. There is consequently a short delay before the rod is released, and in the initial stage of its motion the rod is still influenced by the decaying magnetic field and is thus not falling freely under gravity. Since both rods are affected, errors due to this delay in the release of the rods practically cancel out; it is only the difference in the delay times of the two rods which matters. This difference is minimized by adjusting the currents in the magnet coils so that the forces exerted by the two magnets on their rods are equal.

Although it is only in the first small fraction of an inch that the rod is not falling freely, it takes a relatively long time to fall through this distance, and it is the time during which the rod is influenced by the decaying magnetic field which determines the magnitude of the divergence from the assumed fall under gravity. The effect of this divergence is minimized though not eliminated, by the fact that disjunction is carried out in terms of distance though interpreted in terms of time. Disjunction also tends to eliminate errors due to different delay times for the rods, though in disjunction the circuits are broken near the instrument, while in measuring velocities they are broken at the ends of the cables. The conditions are thus not absolutely comparable.

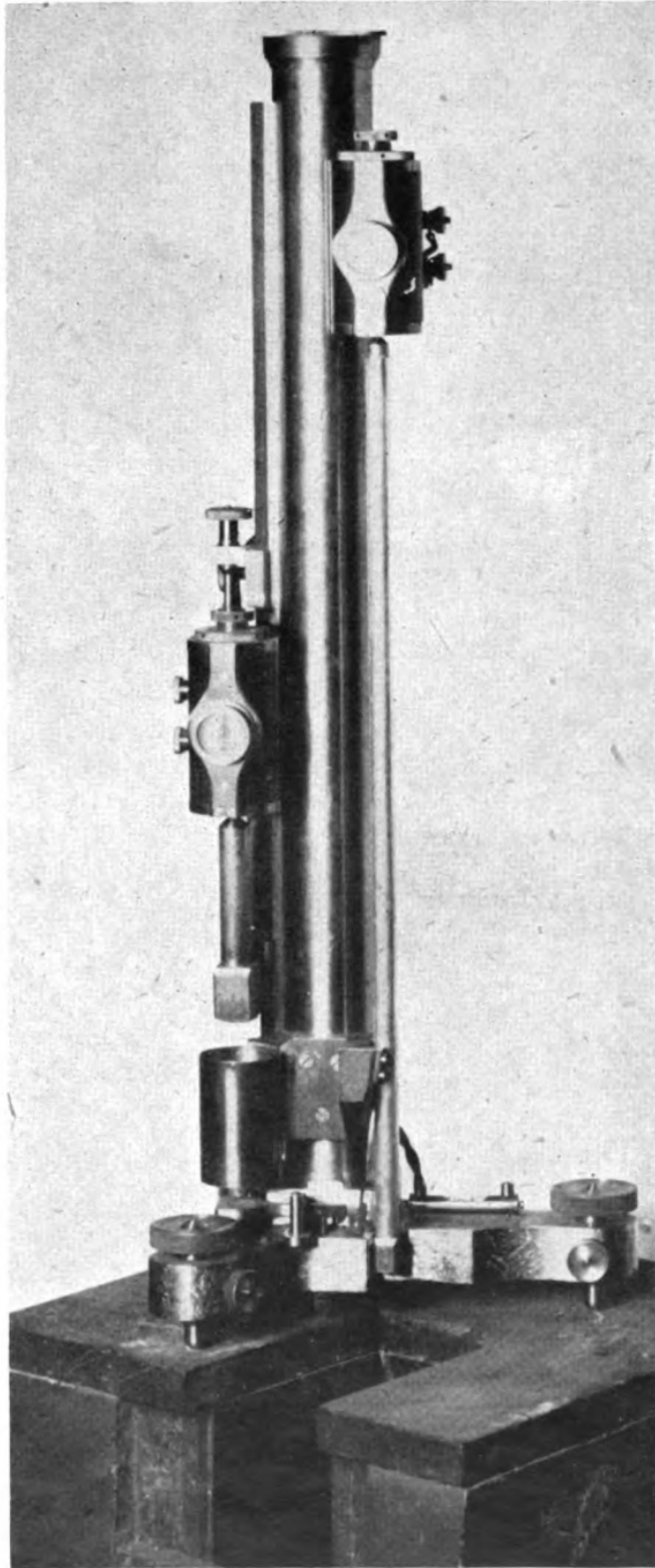

Fig. 12.01. Boulengé Chronograph

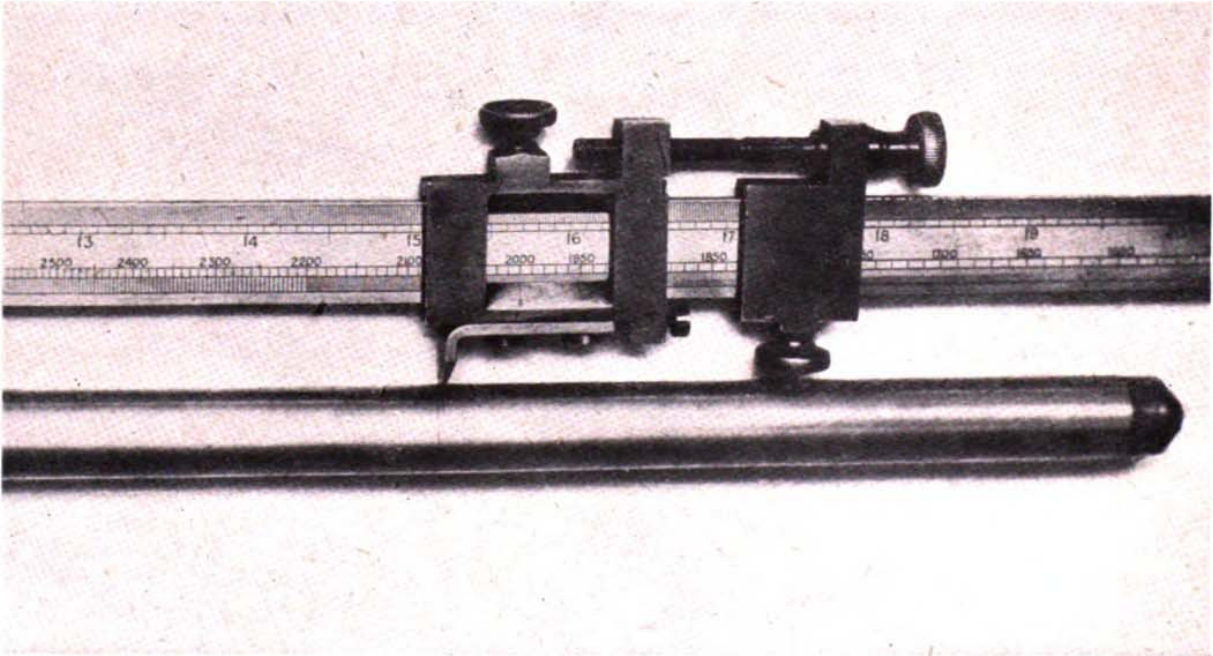

Fig. 12.02. Chronometer scale, old type.

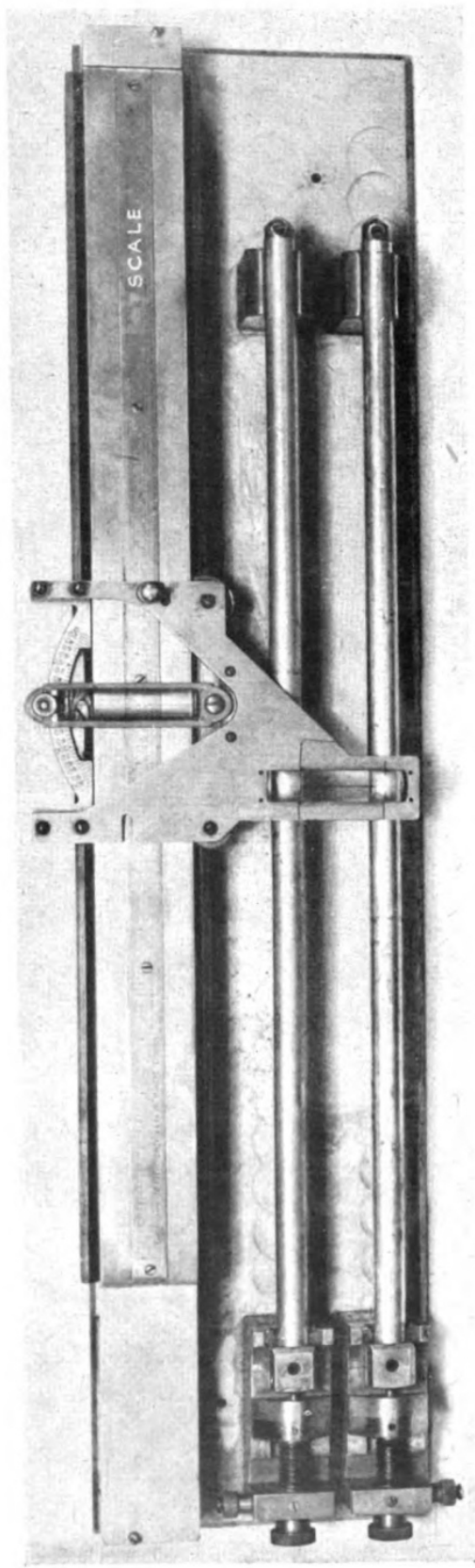

Fig. 12.03. Chronometer scale, new type.

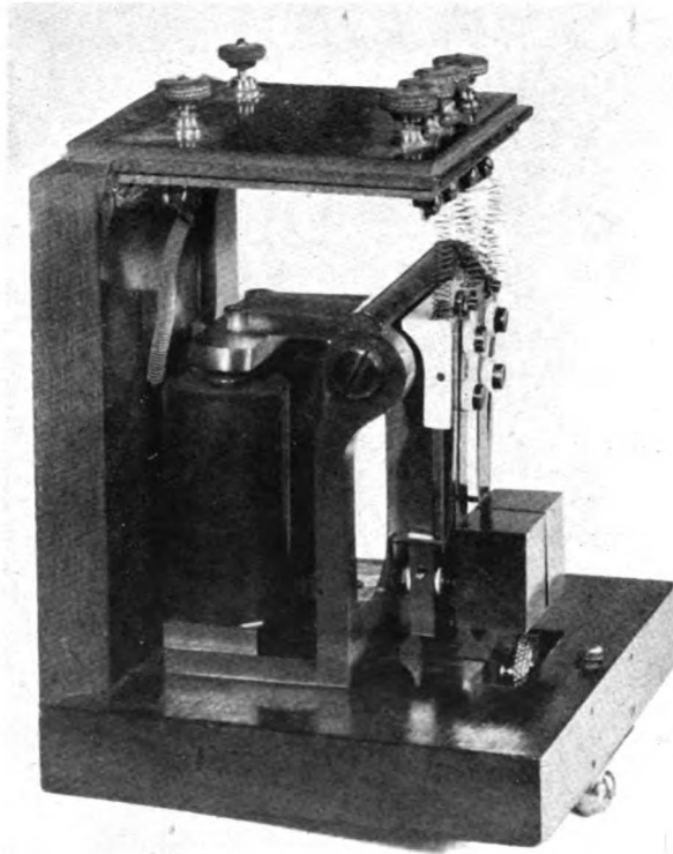

Fig. 12.04. Disjunctor.

In addition to these instrumental sources of error which give rise mainly to systematic errors, and to random errors due to variation in the time of operation of the knife, there are three sources of error due to the operator. Firstly there is the adjustment of the instrument by disjunction and setting the magnet currents ; secondly there is the positioning of the screens ; both of these give rise to systematic errors ; finally, there is the reading of the actual velocity, giving rise to random errors.

From the preceding remarks it will be seen that the accuracy of the Boulengé Chronograph is dependent upon the condition of the particular installation, the adjustment of the instrument and the skill of the operator. It is consequently difficult to give a figure for accuracy apart from stating that for an instrument in good condition with careful and experienced operation an accuracy approaching one part in 1000 can be achieved.

12.05. The P.C.C. system

The basic principle of the P.C.C. (Photo-electric Counter Chronometer) system is the same as that of the Boulengé Chronograph : the time taken by the projectile to pass between two points on the trajectory at a known distance apart is measured and the velocity is deduced from the distance and time. But the means of recording the arrival of the projectile at the two measuring points and of measuring the time interval while the shot is passing between them are entirely different. In the P.C.C. system the two points on the trajectory are determined by the optical fields of view of two photo-cell units, which take the place of the Boulengé screens. The passage of the projectile through the field of view of one of these units obscures some of the light from the sky entering the photocell and thus creates an electrical signal. The two electrical signals thus produced are amplified and fed into an electronic timing device—the counter chronometer—which measures and gives an immediate and direct indication of the time interval between them.

The optical system of the photo-cell units consists of a lens and a slit. The slit is between the photo-cell and the lens, and its position is such that a virtual image of it is formed at a distance above the lens greater than that of the trajectory. This arrangement is shown diagrammatically in Figure 12.05. The width of the slit is chosen so that the width of the virtual image is about equal to that of the lens. In this case, as can be seen in the figure, the field of view of the photo-cell up to the virtual image of the slit is bounded by two planes parallel to the length of the slit and two planes diverging from the lens perpendicular to the length of the slit forming a thin triangular laminar space. Above the image of the slit the field of view diverges in both directions. The photo-cell unit is so placed that the plane of its field of view is at right angles to the vertical plane containing the trajectory. The field of view is thus narrow in the direction of the trajectory, giving a well defined measuring point, but extensive perpendicular to the trajectory, permitting a fair amount of variation in the actual position of the trajectory relative to the photo-cell unit.

For flat trajectories the plane of the field of view of the photo-cell units is made vertical. For firings at elevation the same arrangement (as used with the Boulengé Chronograph), is open to objection on account of the error introduced by any uncertainty in the angle of jump. The magnitude of the angle of jump may be as much as 30' of arc and the round to round variation of the order of 5'. If θ is the nominal angle of departure of the projectile, then the distance along the trajectory between the measurement points is $\sec \theta$ times the horizontal distance between the two vertical fields of view or screens. Consequently if the actual angle of departure is $\theta + \Delta\theta$, the fractional error in the assumed trajectory distance will be $\tan\theta \Delta\theta$, if $\Delta\theta$ is measured in radians. The magnitude of this error is shown in the following table, from which it will be seen that except at low elevations unacceptably large errors are liable to occur.

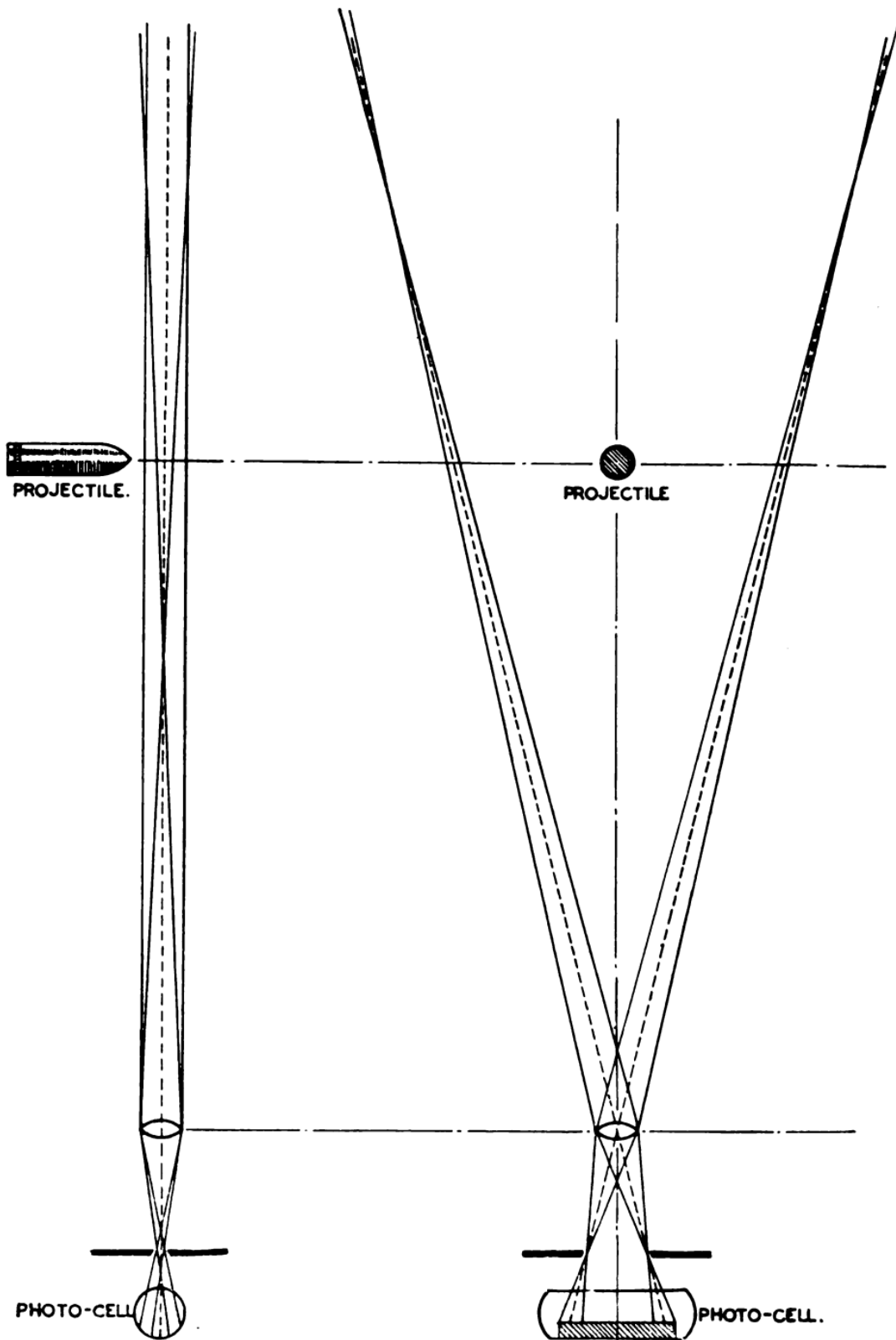

Fig. 12.05. Optical system of photo-electric unit, P.C.C.

PERCENTAGE ERRORS IN ASSUMED TRAJECTORY DISTANCE

| Error in Angle of Departure | Angle of Departure | | | | | |
|-----------------------------|--------------------|------|------|------|------|------|
| | 10° | 20° | 30° | 40° | 50° | 60° |
| 5' | 0.02 | 0.05 | 0.08 | 0.12 | 0.17 | 0.25 |
| 20' | 0.10 | 0.21 | 0.34 | 0.50 | 0.69 | 1.01 |

If the plane of the field of view of the photo-cell unit is oriented so as to be perpendicular to the trajectory then errors due to uncertainty in the angle of jump are effectively eliminated. In this case the fractional distance error is $1 - \cos\Delta\theta$, and an uncertainty of $2\frac{1}{2}^\circ$ only introduces an error of 0.1 per cent. To apply this principle strictly would, however, involve complications in design, and in setting up the unit. These disadvantages are avoided in the compromise scheme which has been adopted in the standard equipment. The units are designed so that the field of view can be set up at either 15° or 35° to the vertical. These two settings enable the field of view to be at not more than 10° from perpendicularity to the trajectory for all elevations from 5° to 45° . Thus even in the worst case the error due to jump uncertainty (corresponding to 10° in the above table) is acceptable.

12.06. The electric signal

The electric signal produced by the photo-cell is proportional to the amount of light which is prevented by the projectile from entering the photo-cell. The shape of the signal is determined by the profile of the projectile, the width of the field of view of the photo-cell unit and the position of the trajectory in relation to the lens and the image of the slit. The simplest case is that of a flat-nosed proof shot, which has a rectangular profile, passing over the photo-cell unit at the level of the image of the slit. The signal increases uniformly as the flat nose of the shot moves across the field of view, it then remains constant until the base of the shot reaches the field of view after which it decreases uniformly until the shot is clear. This is shown in Figure 12.06.

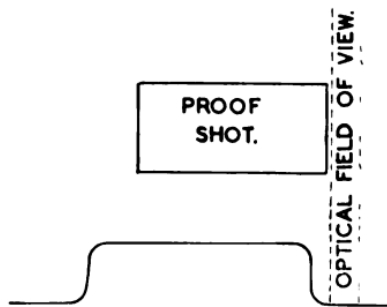

Fig. 12.06. Signal shape, flat-head, P.C.C.

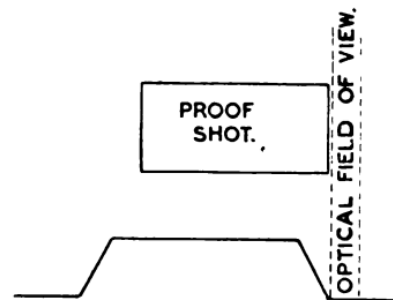

Fig. 12.07. Signal shape, modified, flat-head, P.C.C.

Between the image of the slit and the lens, the rays of light which normally enter the photo-cell are more concentrated in the centre of the field of view than at the edges. If the proof shot passes at this position, then the leading and trailing edges of the signal are modified as shown in Figure 12.07; the degree of divergence from the signal shown in Figure 12.06 is dependent upon the distance of the shot below the slit image. The shot-travel in which the signal builds up from zero to its steady maximum is, however, unaltered.

Under these conditions, with a flat-nosed proof shot, it is the standard practice to use the leading edge of the signal to operate the counter chronometer. The exact point on this part of the signal at which the counter chronometer is operated depends upon the sensitivities of the amplifiers and operating circuits and is when the amplified signal voltage reaches a certain value. Under proper conditions the minimum operating voltage is several times less than the maximum voltage derived from the signal, so that the counter chronometer is operated well within the first half of the leading edge of the signal. However, it is possible for the counter to be operated at any point during this part of the signal and thus the width of this determines the maximum error which can arise from this part of the system. This error is most easily interpreted as a space error and as such it is equal to the width of the field of view.

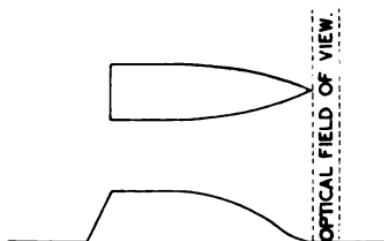

Fig. 12.08. Signal shape, pointed shell, P.C.C.

With projectiles of the normal pointed shape the signal does not reach its maximum value until the base of the ogive has crossed the field of view. The kind of signal produced is shown in Figure 12.08. In this case the shot-travel in which the signal is increasing, that is the maximum space error, is equal to the length of ogive of the projectile in addition to the width of the field of view. However, since the base of the projectile is square the duration of the trailing edge of the signal is much less and corresponds to a shot-travel of the width of the field of view only and if this part of the signal is used to operate the counter chronometer the accuracy of the system is unimpaired. This mode of operation is in fact used on certain types of the standard equipment, and is achieved at the cost of a slight additional complexity in the amplifying and operating circuits.

The unit containing the photo-cell—the Photo-Electric Impulse Unit as it is called—is connected to the other units of the system by a cable which may be up to 1000 yards in length. In addition to the optical system and photo-cell, the photo-electric impulse unit contains a pre-or head amplifier, the purpose of which is to feed the photo-electric signal into the cable at low impedance so as to preserve its steep wave front. The function of the main amplifier—The Impulse Amplifier—is to produce from the chosen part of the photo-electric signal an impulse of sufficient amplitude to operate the counter chronometer.

12.07. The counter chronometer

The counter chronometer is a new type of instrument for the precise measurement of short time intervals. Its essential operations are made electronically and its mode of operation is basically similar to that of a stop watch of which it may be regarded the electronic analogue. It measures time by counting the number of cycles of a standard frequency oscillator which occur in the time interval to be measured.

Electronic counting circuits were first described by Wynn-Williams in 1932,* and since then have been widely used either alone or in conjunction with electro-magnetically operated counting mechanisms for counting events which occur at speeds which are beyond the range

* Proc. Roy. Soc. A, 136, 1932, p. 312.

of an ordinary mechanical counter (200 per second). The main application has been with Geiger Muller counters in atomic or nuclear research. The idea of combining such an electronic counting circuit with an oscillator to measure time was first put forward by Uffelmann of the Research Department, Woolwich (now the Armament Research Establishment) in 1937* and since then many workers have developed instruments based on this principle. The high degree of accuracy of which this type of instrument is capable makes it well suited to the measurement of projectile velocities.

The essentials of a counting circuit are that it shall have two or more states of equilibrium which are changed by the application of a single electrical impulse ; the states being taken up successively in regular rotation. It is also necessary for the counting circuit to indicate which state of equilibrium it is in, so that the count may be observed.

In order to count a considerable number of events, several counting systems can be coupled in cascade, so that each successive stage counts the number of complete cycles of the previous one. The number of counts which a stage makes to complete its cycle is usually known as the *scale* or *scale factor* of the stage. Theoretically, any number may be used for the scale factor, but the most convenient would obviously be 10. The first stage would then count units, the second tens, the third hundreds and so on. As might be expected, it is easier to design a counting circuit with two states of equilibrium, than with ten, and the first electronic counters operated on a scale of two. It is possible to combine four scale-of-two stages to form a single scale-of-ten but in the standard P.C.C. equipment a scale of ten is achieved more neatly by the combination of a scale of two with a scale of five.

In addition to the oscillator, which is running continuously, and the counting circuits, a counter chronometer requires a switching circuit to connect and disconnect the oscillations from the counting circuits at the appropriate instants. The switching circuit is controlled by impulses supplied by an external source. The oscillations applied to the counting circuits must be in the form of impulses, not as sinusoidal waves. This shaping of the output of the oscillator is carried out by part of the switching circuit. Since both the starting and stopping impulses may be received at any phase during one cycle of the oscillator, it will be seen that with a perfect counter chronometer the maximum error will be within ± 1 period of the oscillator, and it can be deduced that the probable error is $\pm \frac{1}{2}$ period of the oscillator.† These errors are slightly larger in practice owing to small time lags in the switching circuit, and when long time intervals are involved the accuracy of the oscillator may have significant effect ; this is not the case in projectile velocity measurement.

12.08. The complete P.C.C. unit

A complete set of P.C.C. equipment comprises three kinds of instrument : photo-electric impulse units, impulse amplifiers and a counter chronometer.

* J. Sci. Inst., 15, 1938, p. 222.

† For a given count the time interval will have begun at a time x before the first impulse counted and will have ended at a time y after the last impulse counted, where both x and y are positive and less than unity.

The error is equal to $x + y - 1$.

Since all values between 0 and 1 are equally probable for x and y , the probable error is equal to the average arithmetic value of $x + y - 1$ for all values of x and y between 0 and 1. Since $x + y - 1$ is negative for $x < 1 - y$, the average arithmetic value of $x + y - 1$ is

$$\int_0^1 \left[\int_{1-y}^1 (x + y - 1) dx + \int_0^{1-y} (1 - x - y) dx \right] dy$$

which is equal to $\frac{1}{2}$. The probable error of a counter chronometer is thus $\pm \frac{1}{2}$ period of the oscillator.

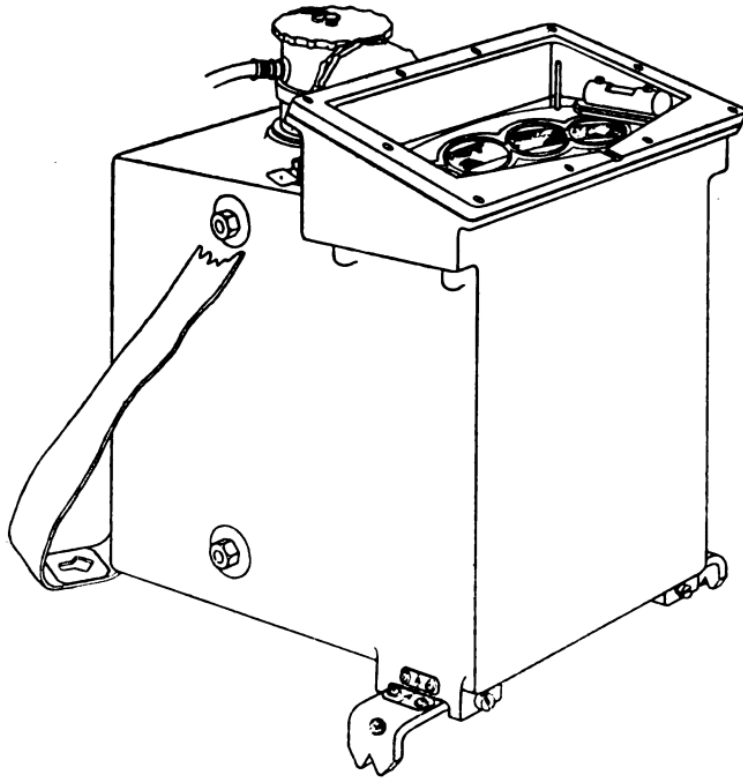
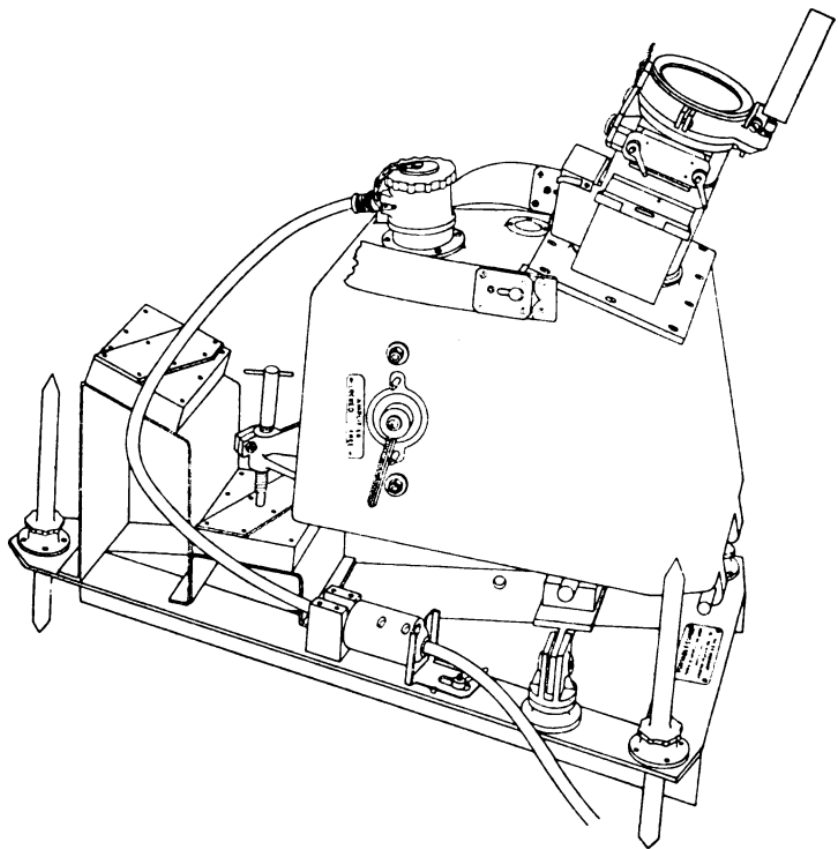

Fig. 12.09. P.E. impulse unit,
type P.B.

Fig. 12.10. P.E. impulse
unit, type E.



Different types of photo-electric impulse unit have been designed to meet different requirements. Two types are illustrated in Figures 12.09 and 12.10. These are Type PB, which has been designed for proof butts work, that is for flat trajectories up to about 8 feet above the ground, and Type E, which has been designed for firings at elevation. The optical system of the Type E corresponds with the description given above ; in the Type PB a wider field of view, perpendicular to the trajectory, is obtained by using four lenses and a single curved slit. With its appropriate main amplifier, the sensitivity of the P.E. Impulse Unit, Type PB is sufficient for recording small arms bullets which only obscure about $\frac{1}{2}$ per cent. of the light entering the photo-cell. The sensitivity of the P.E. Impulse Unit Type E is sufficient to record a 3-inch calibre projectile passing at 100 feet above the unit even under rather poor skylight conditions.

The impulse amplifier and counter chronometer are built on standard 19-inch panels for rack mounting and are conveniently mounted together as shown in Figure 12.11. The impulse amplifier contains two twin amplifiers, one for the start signal and one for the stop signal. There are two pairs of controls, one for adjusting the filament currents of the pre-amplifiers in the p.e. impulse units, the other for adjusting the overall sensitivity.

12.09. Accuracy of the P.C.C. system

The accuracy of velocity measurement by this system depends upon the accuracy of the distance measurement and the accuracy of the time measurement. Errors in the distance measurement are composed of errors in the assumed distance along the trajectory between the optic axes of the two photo-electric impulse units and errors due to the finite width of the field of view of these units. For the Type E impulse units the trajectory distance is calculated from the measured distance between the two units, the inclination of the fields of view of the units to the vertical, and to the trajectory, and their relative heights. The main possible sources of error are lack of parallelism between the two fields of view, and in the measured distance between the units. The inclination of the field of view of the impulse unit is adjusted by reference to a bubble to an accuracy of 1 minute of arc or better ; at the maximum height of the trajectory above the unit—100 feet—this corresponds to a distance accuracy of $\frac{1}{3}$ inch. The distance between the two units is usually about 100 feet and with reasonable care can be measured to $\frac{1}{8}$ inch. For the type PB impulse units, the trajectory passes so near to the units that there is little scope for error due to lack of parallelism of the two fields of view. For this type of unit the width of the field of view is rather less than 1 inch, and this is thus the maximum error which can be introduced by the finite width of the field of view. The probable error is very much less—about $\frac{1}{8}$ inch—since the magnitude of the photo-electric signal is usually several times that required for operation and the maximum error could only arise if the sensitivity of one amplifier was only just sufficient to operate the counter chronometer, while that of the other was many times greater—a most unlikely occurrence. The accuracy of time measurement has already been discussed and the maximum error shown to be ± 1 cycle of the oscillator and the probable error $\pm \frac{1}{3}$ cycle. The oscillator frequency is 100 kc/s and so these errors are ± 10 microseconds and ± 3 microseconds respectively. The overall accuracy depends upon the velocity and the distance between the two impulse units ; taking as an example a velocity of 3,300 feet per second and the standard distance between the units of 100 feet, it will be seen that the maximum error due to time measurement is 1 part in 3000 while the maximum distance error is 1 part in 1000. Combining these two errors the maximum error in velocity measurement is 1 part in 750 for gross maladjustment of the amplifier sensitivities while the probable error is about 1 part in 3000.

It should be noted that the largest errors are distance errors and are systematic ; they are associated with the layout and adjustment of the impulse units. The errors in timing are smaller ; these are random and entirely independent of the operator's skill.

INTERNAL BALLISTICS

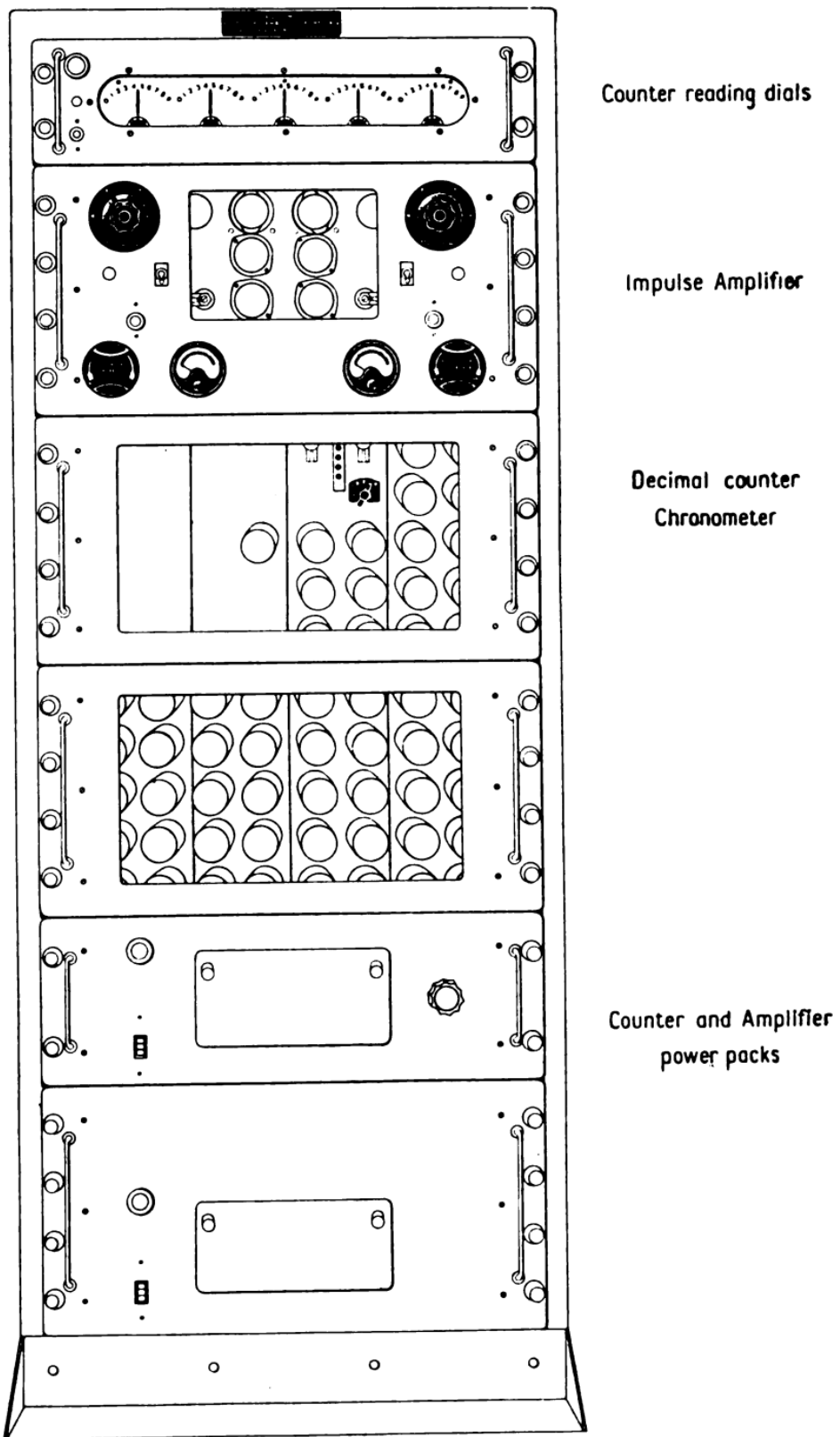

Fig. 12.11. Impulse amplifier and counter chronometer assembly.

12.10. Muzzle velocity

Except for one brief reference in Section 12.03, the conversion of the observed velocity at some distance from the muzzle to velocity at the muzzle has not yet been considered.

For most internal-ballistic purposes the muzzle velocity is obtained from firing proof-shot horizontally into a butt. In these circumstances Siacci's equation* can be used with satisfactory accuracy. It is

$$S(V) = S(v) + x/C$$

where v and V are the observed and muzzle velocities respectively in feet per second, x is the mid-screen distance from the muzzle in feet and C is the *ballistic coefficient* of the shot ; $S(v)$ is Siacci's *space function* and is given, for proof-shot, in Table VIII, Text Book of Ballistics and Gunnery, Part I, (1938) ; it is, of course, a function of the air-resistance to the shot.

The ballistic coefficient is

$$C = w/\tau d^2$$

where w is the mass of the shot in pounds, d is the calibre in inches and τ is the coefficient of tenuity ; this latter coefficient represents the density of the air and depends on the barometric pressure, the temperature and the degree of saturation ; it is tabulated in Table VII in the above-mentioned Text Book.

This method is based on the assumption that the only horizontal force acting on the shot between the muzzle and the mid-screen position is the resistance of the air. Actually this assumption is not quite justified since the propellant gases emerging from the muzzle tend to accelerate the shot for a short distance. It has not yet been possible to measure the effect of this acceleration and all we can state with certainty is that the muzzle velocity deduced by the above method is slightly greater than the true muzzle velocity. The error must obviously be small, but how small is not known.

* F. Siacci, *Corso di balistica*, Torino, 1888.

CHAPTER XIII

CLOSED-VESSEL WORK AND THE MEASUREMENT OF PRESSURE IN VESSEL AND GUN

13.01. Introduction

It is the purpose of the first part of the present chapter to give a brief description of the technique of closed-vessel experiments. The theoretical aspects of burning at constant volume have already been discussed and Sections 13.02 to 13.03 are to be regarded as supplementary to Chapter V.

Pressures in both closed vessels and guns are comparatively large and vary rapidly with time. Special methods of measurement have had to be devised. These are briefly described in the later sections of this chapter.

13.02. The closed vessel

A design of closed vessel for use in routine investigations is shown in Fig. 13.01. The vessel has been designed to operate at maximum pressures up to 18 tons/sq. in., i.e., at pressures comparable with those obtaining in a gun.

The body is a steel cylinder threaded internally at both ends to receive closing plugs. It is of heat-treated nickel steel and is lined with a cylinder of nickel-chrome-molybdenum steel, the purpose of the liner being to facilitate repair in the event of damage occurring to the obturator seatings through gas wash or crack formation. Efficient obturation at the high pressures encountered in closed-vessel work is a formidable problem and its solution requires a somewhat complex system of pads and washers.

Buttress threads are used on the closing plugs as such threads are less liable to seize than V-threads. One plug carries the pressure gauge, that shown in the figure being of the piezo-electric type described in Section 13.06. Brass rings provide gas-tight joints between the closing plugs and the vessel bore. Two annular grooves on the external surface of the rings reduce their bearing areas and thus tend to increase the effectiveness of the joints. It is not necessary to screw up the plugs very tightly to ensure a perfect seal, but, even so, the rings are compressed slightly after each round and must be replaced when the ends of the plugs make contact with the liner.

The firing electrode is housed in the second closing plug, suitable insulation being arranged. The borings for both this electrode and the pressure gauge are bushed so that damage due to obturation failure may readily be rectified. The second closing plug is also fitted with a valve for introducing an igniter gas mixture into the vessel and for releasing the combustion products after firing.

In order to reduce sampling errors, it is, of course, desirable to use as large a propellant charge as possible. Closed vessels are designed to withstand specified maximum pressures, and this puts a limit to the charge weight for unit volume capacity of the vessel which can safely be fired. Thus, for a given design pressure, the weight of the vessel is proportional to the charge weight, and it is necessary to make a compromise between charge weight and vessel weight. In the design of Fig. 13.01 the chamber capacity is 700 c.c. ; with the maximum pressure limited to 18 tons/sq.in., this permits the firing of 140-gram charges of propellants such as SC and WM (i.e. density of loading = 0.2 grams/c.c.).

A long, narrow chamber is undesirable for two reasons ; firstly, it provides favourable conditions for the building up of pressure pulses, and secondly, cooling is excessive. For minimum cooling losses in a vessel of given volume the chamber should be spherical but this would introduce various complications both in design and manufacture. In the present design, the chamber length is twice the diameter.

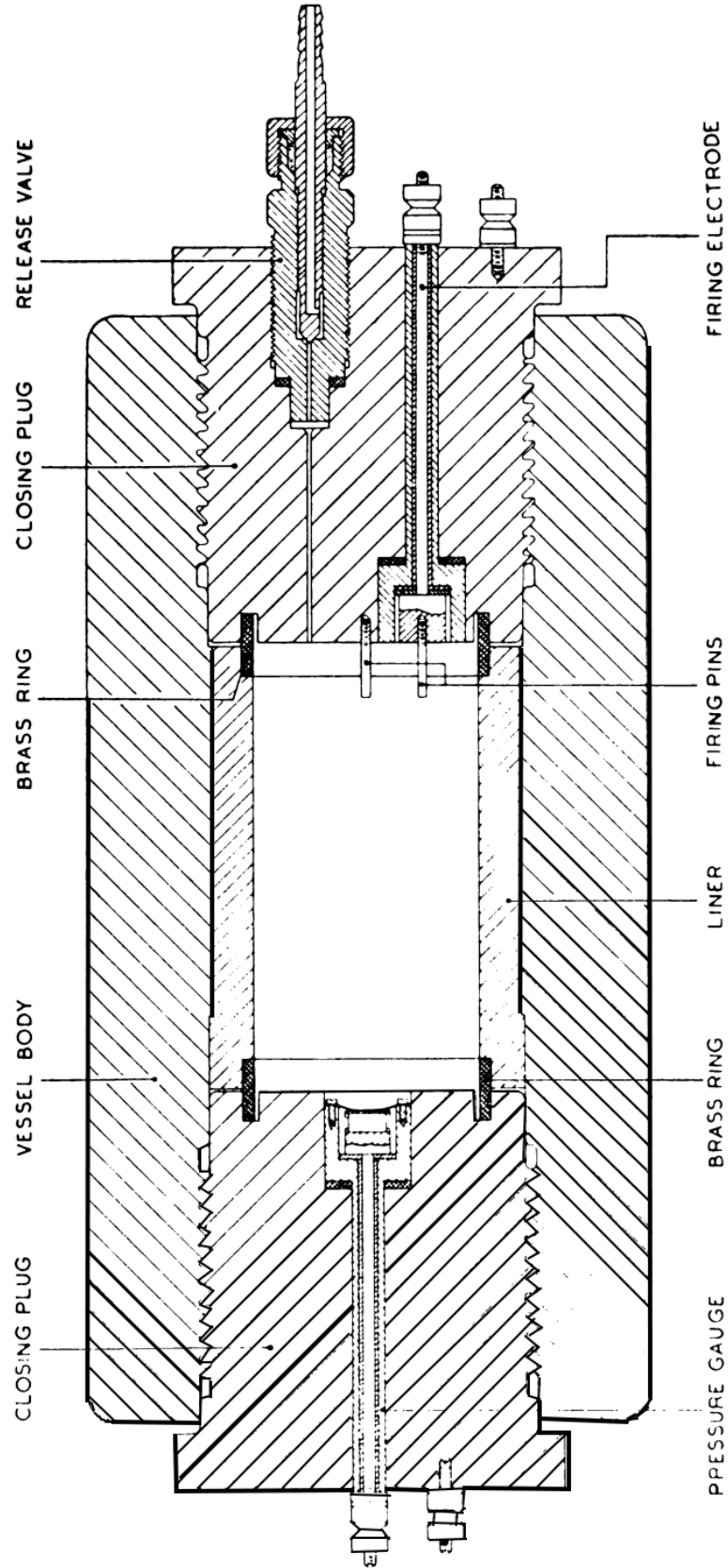

Fig. 13.01. Closed vessel.

The absence of radial fittings permits the use of a simple water-jacket for controlling the temperature of the vessel. The jacket consists essentially of a box made from steel plates welded together along their edges, with holes in two opposite sides of sufficient diameter to allow the vessel to pass through them. The jacket is fitted with drain, overflow, hot-water and cold-water pipes and the lid is detachable so that ice may conveniently be packed round the vessel.

13.03. Firing a round in the closed vessel

As, in general, the rate of burning of a propellant is sensitive to its initial temperature, it is important that the closed-vessel charge should be under temperature control for some time before it is fired. The charges are weighed out accurately, and are then stored for at least 24 hours at the temperature at which they are to be fired. The temperature of the vessel is adjusted by running hot or cold water into the water-jacket, or by filling it with ice, depending upon the temperature required.

The annular clearance between the firing-plug and the inner surface of the sealing-ring is filled with thick luting or plasticine, and the clearance round the head of the firing electrode is filled with vaseline. A short length of No. 50 S.W.G. (= .001 inch dia.) nichrome resistance wire is soldered to the two firing pins, which are then protected with a weighed amount of luting. If necessary, the valve cone and seating are cleaned. The block is then thoroughly cleaned, and thin luting or vaseline is applied to the exposed end of the sealing-ring to make a vacuum-tight joint when the block is screwed into the vessel.

The vessel interior is carefully cleaned, special attention being devoted to the sealing-ring seatings. The firing-plug is then screwed into the vessel; a ring-spanner is fitted over the hexagonal end of the plug, and is tapped two or three times with a light hammer. Assuming that the vessel is at the required temperature, the propellant charge is placed in the chamber, taking care not to break the fuse-wire. The vessel is now left an hour or two in order to allow any temperature differences to smooth out.

The gauge-plug is prepared for use by filling the annular space between the gauge and electrode bush with vaseline, almost to the top of this cavity. A pad of luting is placed over the top of the vaseline to provide further protection from the hot products of propellant combustion. The clearance between the plug and the inner surface of the sealing ring is thoroughly cleaned, and the end of the ring is smeared with vaseline or thin luting. When the vessel has reached the required temperature the gauge-plug is screwed in and tapped home, as in the case of the firing plug. A vacuum pump is connected to the hollow valve-spindle, and the vessel is evacuated to a pressure of about one-third of an atmosphere. Ethylene and oxygen are then introduced into the vessel in amounts corresponding respectively to pressures of approximately 14 and 30 cms. of mercury, and then air is allowed in to bring the pressure up to atmospheric. The release valve is closed, the gauge- and firing-leads connected, the gauge amplifier adjusted and the vessel is ready for firing.

13.04. Pressure measurement in closed vessel and gun

There are two distinct requirements for pressure measurement in internal ballistics. One is to meet the requirements of gun proof, propellant proof and other routine firings for which a measurement of the maximum pressure in the gun is sufficient. The other is for internal-ballistic research: in this case a continuous record of the development of gas pressure within a gun or closed vessel is desired.

The first requirement is naturally the easier of the two and is met universally by some form of crusher gauge. In this type of gauge the gas pressure is applied by means of a piston to a test piece of copper or other metal, contained within the body of the gauge, and the amount

of deformation of this test piece is used as a measure of the maximum gas pressure to which the gauge has been subjected. This type of gauge is simple in operation and consequently well suited to routine measurements.

The second requirement is far more difficult to meet, especially as a fairly high degree of accuracy is necessary if the results are to be of much use. The piezo-electric method of pressure measurement is generally used for this purpose, to which its special qualities are well suited. For the gun, some form of electric gauge is essential to overcome the difficulty of recoil and the recording apparatus must be housed some distance away. A piezo-electric gauge has a very high natural frequency and the high pressures and short times characteristic of the phenomena to be measured represent optimum conditions for the method since these minimize its disadvantages of low sensitivity and susceptibility to electrical leakage.

A pressure head embodying wire-resistance strain gauges is sometimes used instead of the piezo-electric gauge.

Pressure measurement in the closed vessel was, up to the end of 1918, performed by recording the compression of a copper crusher and attaching to the piston a stylus which traced out a line on smoked paper carried on a revolving drum. Although a copper crusher can be made to give an approximate measure of the maximum pressure, it is unsuitable for continuous recording as plastic deformation alters the character of the copper in a way which is so complex that no estimation of the stress-strain relationship is possible. If all that is required is the pressure-time relation it is not difficult to design a satisfactory gauge relying on the purely elastic displacements of a spring. In closed-vessel work it is, however, usually necessary to determine the rate of change of pressure and the amplitude of the gauge oscillation has to be kept very small. A special spring gauge for closed vessel work has been developed and a description of it is given in Section 13.08.

13.05. The crusher gauge

The design of the present Service crusher gauge is shown in Fig. 13.02. The gauge consists of a short hollow steel cylinder into which is screwed a cap through the centre of which a hole is carefully lapped to receive a piston of $\frac{1}{6}$ sq. in. cross-sectional area. A specially-prepared cylinder of copper—known as the *copper*—is placed between the piston and the bottom of the gauge, and is supported laterally by a light spring. A copper gas check is fitted

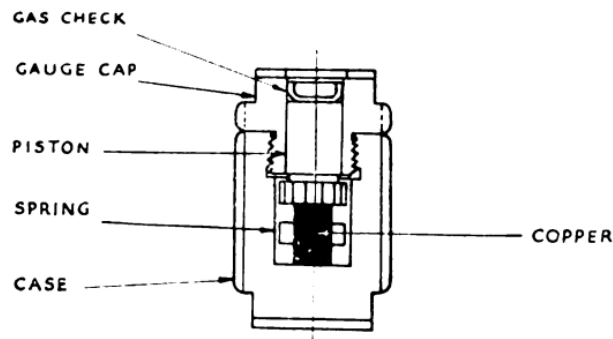

Fig. 13.02. Service crusher gauge.

to the exposed end of the piston to prevent the penetration of gas to the inside of the gauge ; it also serves to hold the piston in contact with the copper. This design of gauge is loaded loose with the propellant charge. There is another design, with identical functioning components, which can be screwed into a radial boring in the gun barrel.

When the gauge is subjected to pressure the copper is compressed and from the amount of deformation, measured by a micrometer, the pressure is deduced from tables constructed

from static pressings. It is now generally recognised that the pressure measured in this way is about 20 per cent. below the true value, but the reason for this discrepancy is not clear. Friction between the gas check and the gauge body has been offered as an explanation but the replacement of the copper gas check by grease does not materially reduce the discrepancy. The amount of compression used is quite large, at 20 tons per sq. in. pressure the reduction in length of the copper is 45 per cent. It has been found that if much smaller compressions are used (by reducing the area of the piston relative to the copper) the difference between static and dynamic readings is practically eliminated. However the practical adoption of this principle presents difficulties both in routine measurements to one ten-thousandth of an inch and in the mass production of coppers with sufficiently uniform behaviour under the required conditions. This latter difficulty has not been overcome.

In the United Kingdom it is the practice to use pre-compressed coppers, that is, coppers which have been subjected in a static machine to a thrust corresponding to a pressure acting on the gauge of about 4 tons per sq. in. below the expected pressure. The reason for the adoption of this system is that by reducing the movement of the piston any effects due to the inertia of the piston and copper are also reduced. It can be shown, however, that even with uncompressed coppers the inertia effect is trivial under normal gun conditions of rate of pressure rise. Nevertheless the use of pre-compressed coppers is valuable in that the performance of each copper is checked before use; after pre-compression the deformation of the coppers is measured and only coppers with deformations within specified limits accepted.

The coppers are made from the purest copper commercially obtainable, at least 99.5 per cent. pure, supplied in rods about 6 ft. long and 0.32 in. diameter. These rods are cut into lengths of approximately 0.6 in., and adjusted accurately to a weight of 0.215 oz. by grinding the ends. The pieces are then pressed in a former so that their length is 0.5 in. and diameter 0.326 in., the tolerance on these dimensions being 0.0005 in. Different batches, and even different rods in the same batch, vary considerably in hardness. These differences are removed by annealing. For each batch of coppers an annealing temperature between 500° and 650° C. is determined so that test specimens from the batch give the correct compression according to the standard table when subjected to a load corresponding to 6 tons per sq. in. pressure.

Generally two gauges are used per round although with the largest-calibre guns more are employed.* Before a new gauge can be used it must go through a *salting* process. This process is carried out by including the gauge in gun firings first at low pressures and later at normal and proof pressures. The reading of the gauge is compared with accepted gauges and the gauge itself examined. Any seizing of the piston is corrected by lapping the hole in the cap of the gauge. When the gauge reads in agreement with accepted gauges for several rounds it is passed for use. This salting process may take from 6 to 20 rounds.

In addition to the large systematic error already discussed, the readings of the crusher gauge are subject to random errors. The probable value of these amounts to rather more than 1 per cent.

13.06. The piezo-electric gauge

Certain crystals, when stressed, develop electric charges of opposite signs at the ends of what are called electric axes. This phenomenon is called piezo-electricity and was first applied to the measurement of explosion pressures by Sir J. J. Thomson in 1917. Since then it has been found particularly well-suited to the measurement of pressures in internal ballistics and has been widely adopted for this purpose.

The practical application of this phenomenon to the measurement of pressure involves first, the subjection of the crystal to the pressure to be measured, and second, the measurement

*See Section 14.05

of the electric charge developed. One of the chief sources of difficulty in this method is the smallness of the charge to be measured ; even with the high pressures developed in internal ballistics the charge is usually less than 0.1 micro-coulomb. The great advantages of the method are the very high frequency of response of the crystal and the constancy of calibration, enabling a high degree of accuracy to be attained.

The device which houses the crystal and subjects it to the pressure is usually called the gauge. There are two types of piezo-electric gauge ; one is based on the use of quartz as the piezo-electric substance, the other on the use of tourmaline. Quartz has three electric axes and when hydrostatic pressure is applied to it the three pairs of charges mutually cancel out so that the net effect is nil. In order to use the piezo-electric properties of quartz it is usual to apply a thrust to the crystal in the direction of one of its electric axes. The pressure to be measured must therefore be transmitted to the quartz by means of a piston, or diaphragm. An example of this type of piezo-electric gauge is illustrated in Fig. 13.03.

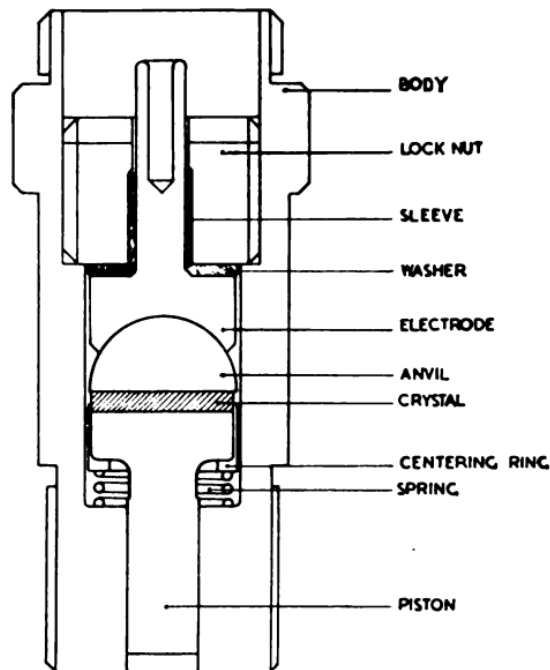

Fig. 13.03. Piezo-electric gauge (Quartz).

The tourmaline type of piezo-electric gauge has been developed and used in the United Kingdom. It has the advantage that the crystal can be subjected to hydrostatic pressure and it thus avoids the potential sources of inaccuracy associated with the use of pistons for pressure measurement. The elimination of the piston leads to a very simple design of gauge ; an example is illustrated in Fig. 13.04. In this gauge one face of a disc cut from a crystal of tourmaline is cemented to an insulated electrode, a plate is cemented to the other face and connected to the body of the gauge. The interior of the gauge, containing the crystal, is filled with grease which protects the crystal from the hot ionized explosion gases and transmits the pressure to it.

For pressure measurement in guns it is most convenient for the gun barrel to be bored to receive a gauge. It is possible however, to mount piezo-electric gauges inside the cartridge or on the face of a specially prepared vent axial and thus obtain a continuous record of pressure against time without modifying the gun barrel in any way. Typical arrangements are shown in Fig. 13.05.

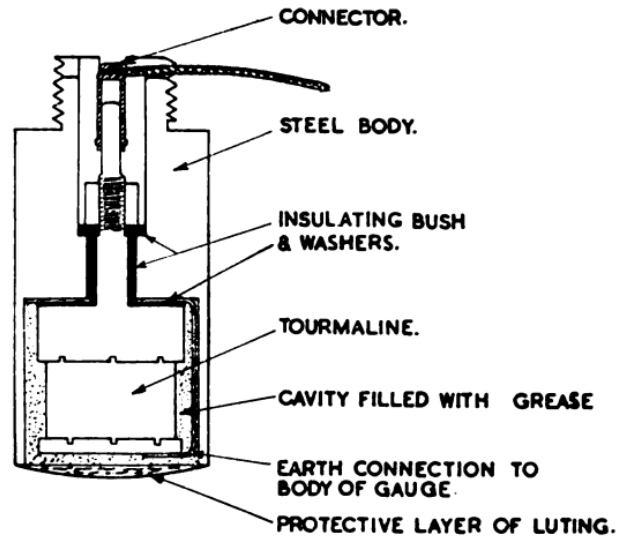

Fig. 13.04. Piezo-electric gauge (Tourmaline).

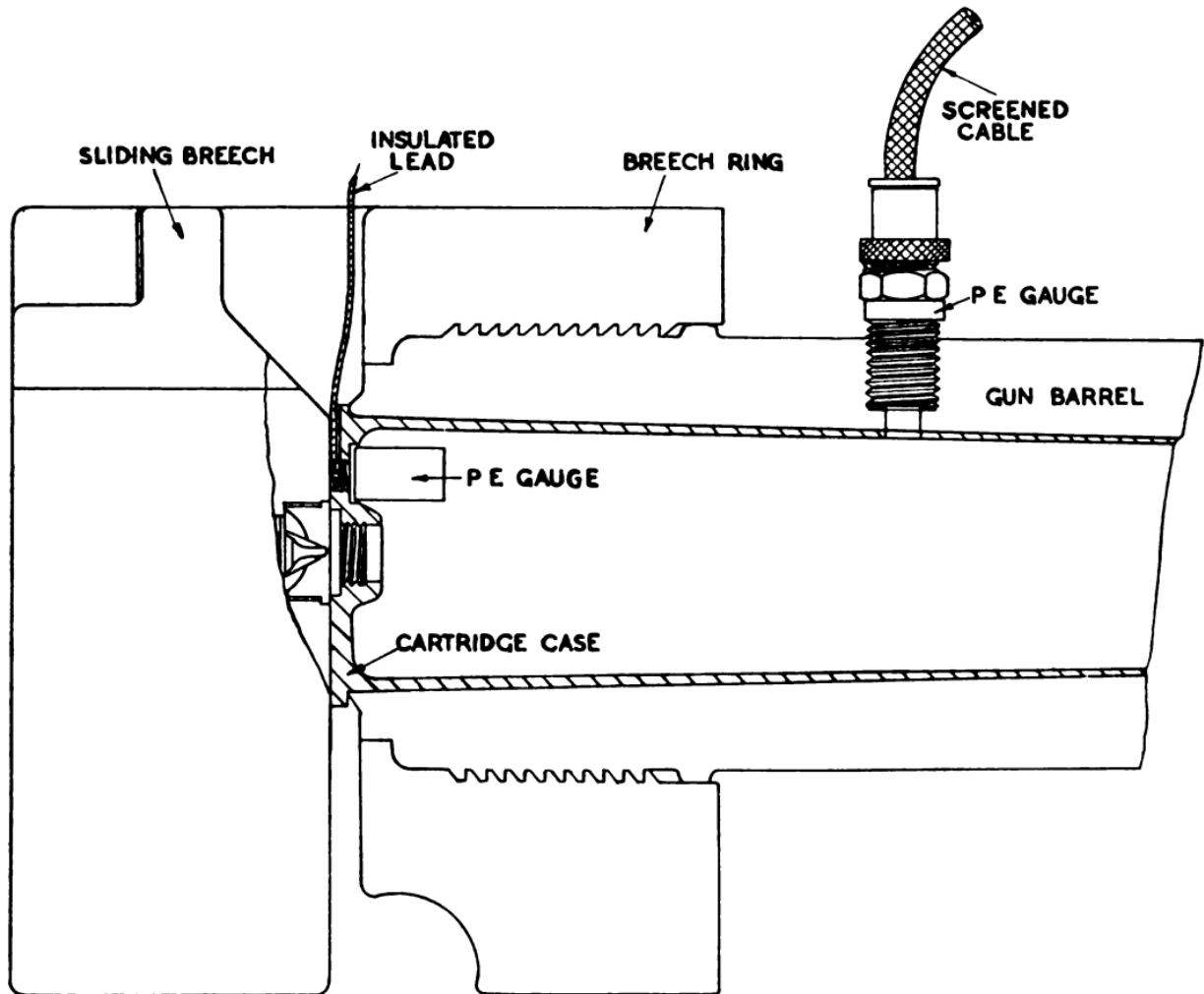

Fig. 13.05. Arrangement of piezo-electric gauges in gun.

The piezo-electric gauge translates the variations of pressure applied to it into exactly corresponding variations of electric charge. The variations of electric charge are recorded by a cathode-ray oscillograph at a convenient distance away from the gun or closed vessel, the gauge being linked to the oscillograph by an electric cable. The cathode-ray oscillograph by itself records the variations of the voltage applied to the deflecting plates of the cathode-ray tube. It is therefore necessary to convert the output of the gauge from one of electric charge into one of voltage, and, further, to one of voltage of sufficient amplitude to operate the cathode-ray tube. The first step is an easy one and is achieved by connecting a condenser across the output of the gauge. By using a condenser of sufficiently small capacity, the voltage generated by the charge would be high enough to operate the cathode-ray tube, but the smallness of the charge and the amount of electrical leakage at this relatively high voltage make this arrangement impracticable. A condenser of larger capacity is therefore used and the resulting smaller voltage is amplified to the required level. Adjustment of the capacity of the input condenser forms a convenient means of adjusting the input voltage to the amplifier, so that, whatever the magnitude of the pressure, the input voltage to the amplifier can be kept constant and the amplifier can operate at constant gain.

It is not proposed here to give any details of the amplifier, except to remark that the special requirements are not easily met. These are that the input of the amplifier must have a very high effective insulation so that no perceptible leakage of the piezo-electric charge can take place while the record is being obtained, and that the amplification shall be constant for all frequencies from 0 up to at least 10 Kcs. so that a faithful record is obtained.

The magnitude of the deflection ultimately recorded on the photographic film is determined by (i) the pressure, (ii) the gauge sensitivity, (iii) the capacity of the input condenser, (iv) the gain of the amplifier, (v) the sensitivity of the cathode-ray tube and (vi) the magnification or reduction of the optical system. The combined effect of the last three factors is measured by an automatic calibration which forms part of each record. By a special switching arrangement a series of known voltages is applied to the input of the amplifier immediately before firing. The oscillogram is thus calibrated in terms of voltage: with the appropriate values for the input capacity and gauge sensitivity this voltage calibration is easily converted into one of pressure. The gauge sensitivity is determined by subjecting the gauge to a known pressure in a dead-weight press, and recording, with the same amplifier and oscillograph, the rapid release of this pressure. The accuracy of pressure measurement obtainable by this arrangement is rather better than 1 per cent. Fig. 13.06 is a reproduction of a piezo-electric record of the pressure development in a gun.

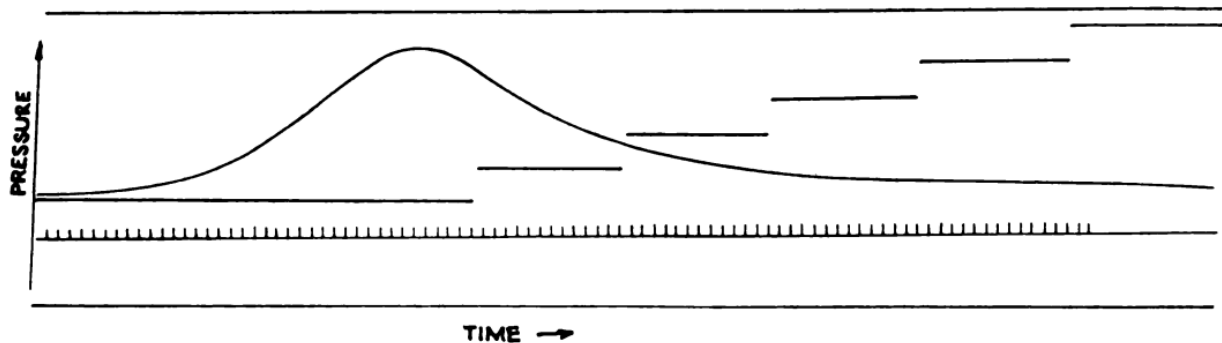

Fig. 13.06. Typical P.E. record in gun.

13.07. Strain-gauge pressure head

A design of pressure head embodying wire-resistance strain gauges is shown in Fig. 13.07. The body is tubular with the end threaded to fit a hole in the wall of the gun chamber. The annular face seats on a flat, copper, sealing washer. The piston is a good fit in the bore of the body and transmits the gas pressure to a compression member which bears on a nut. This puts the body tube in tension. The cross-sectional areas of the body and compression member are the same, so that the tensile and compressive strains are equal. Two wire-resistance strain gauges are cemented longitudinally to the compression member and two more gauges attached to the outside of the body. The four gauges are connected electrically to form a Wheatstone bridge, energised by a 40-volt battery.

On applying pressure to the piston the resistance of the strain-gauge elements changes, giving an electrical output from the bridge which can be indicated on a galvanometer, or in the case of varying pressures, may be recorded by a cathode-ray oscillograph. The sensitivity of the complete gauge is about 6 milli-volts per ton per sq. in.

An extra pair of strain gauges, fixed on the outside of each body, serves to measure the *difference in pressure* between two heads placed in different positions in the chamber. The gauge is calibrated statically by the application of a dead load giving a pressure of 10 tons per sq. in.

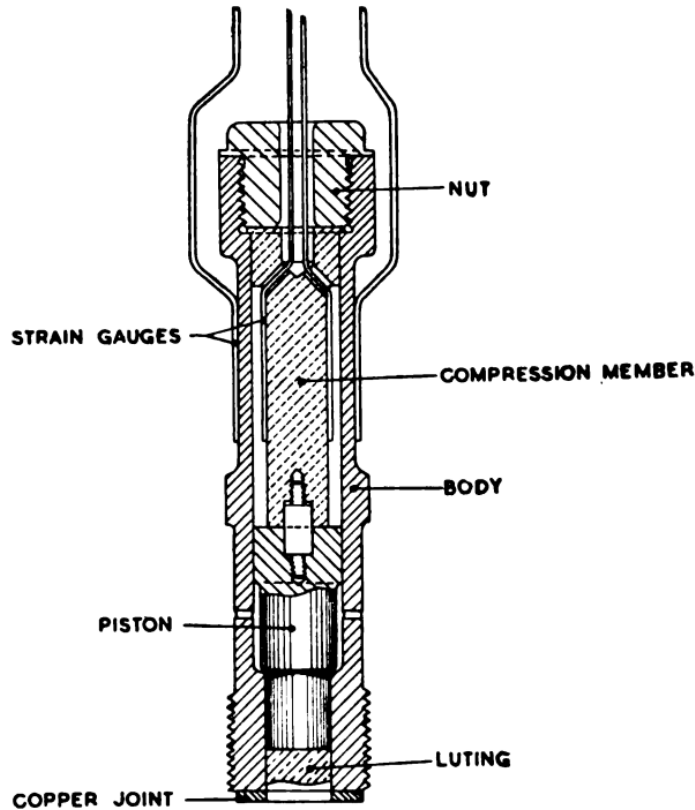

Fig. 13.07. Strain gauge.

13.08. The spring gauge

In spite of the outstanding advantages of piezo-electric and strain gauges, spring gauges are not entirely obsolete. They have some value in closed-vessel work as a laboratory sub-standard and the not inconsiderable advantage that they require little specialised knowledge to handle them.

The low frequency of the conventional type of gauge, such as the engine indicator, is due partly to the inefficient use of the spring material, and partly to the use of a large piston displacement combined with a low magnification. Most of these instruments employ helical springs in which the metal is stressed in torsion so that only the outer layers are fully stressed. The conditions under which they are commonly used make it impossible to employ high magnification.

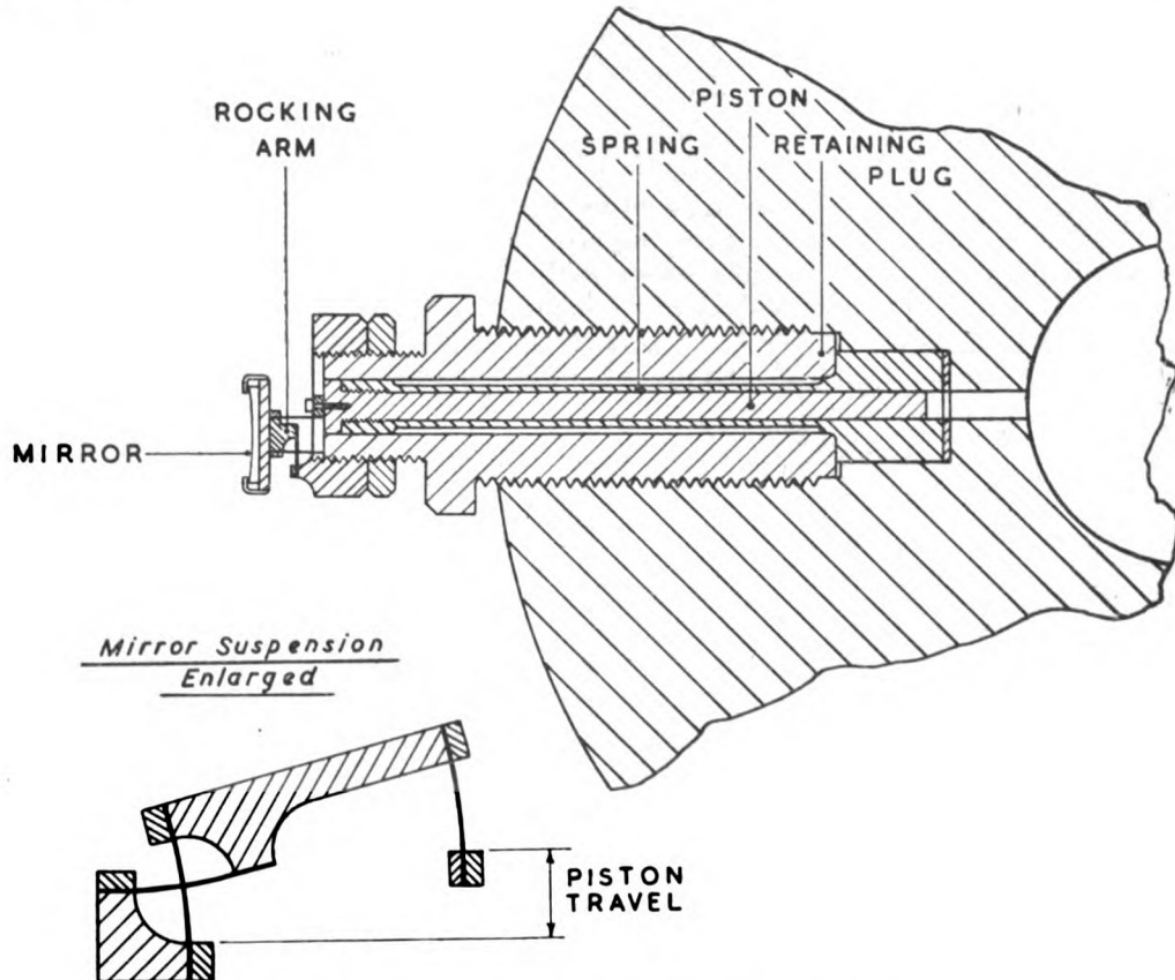

Fig. 13.08. A.R.E. spring gauge, first design.

The current principles on which a gauge of really high frequency for high-pressure work should be designed were laid down by Petavel. Another early designer of a satisfactory gauge was Thring. Both designs were based on a working spring member consisting of a cylindrical steel tube loaded axially. The displacement of such a spring is small and recording is through an optical system employing a tilting mirror giving a magnification of over 200. The design of the Thring gauge is such that its use is confined to vessels whose walls are quite thin—its use in practice has been almost exclusively confined to work on small-arms, for which it is admirably suited. It is not really suitable for use with closed vessels with thick walls.

Two types of spring gauge, based on the principles laid down by Petavel, have been developed by C. M. Balfour. The smaller of the two has been described by Crow and Grimshaw* who also gave a full account of the extensive tests to which it was subjected. The gauge is

* Phil. Trans. Roy. Soc. A, Vol. 230, pp. 42-44 (1931).

illustrated in Fig. 13.08. It will be seen that instead of the spring being compressed by the piston, it is anchored at its inner end by the retaining plug, and the piston fits inside it so that gas pressure stresses the spring in tension. An advantage of this design is the reliability of the gas seal at the end of the piston.

The mirror suspension is mounted on a ring which screws on to a spigot at the outer end of the gauge body. The mirror is held by a light ring on to the face of a rocking arm controlled by a group of flat steel springs. This group is an example of the *crossed-spring* pivot commonly used in measuring instruments of high resolution and accuracy. Like the torsion strip it acts as an ordinary pivot but without friction or backlash. The angular displacement of the mirror is closely proportional to the piston displacement so long as the latter is small in comparison with the distance between the parallel springs.

This gauge has a much higher frequency than the original Petavel pattern, about 300 periods per second, but inevitably the mass of the piston is large in comparison with that of the spring. A different lay-out was adopted for a second gauge, illustrated in Fig. 13.09, and fully described by Balfour.* Here the spring is the only part under high stress and the push rod can be very light. The natural frequency is high and, in practice, is only limited by the fact that the main spring cannot well be less than a certain length, depending on the wall-thickness of the vessel, and on the degree of magnification of its compression which is practicable.

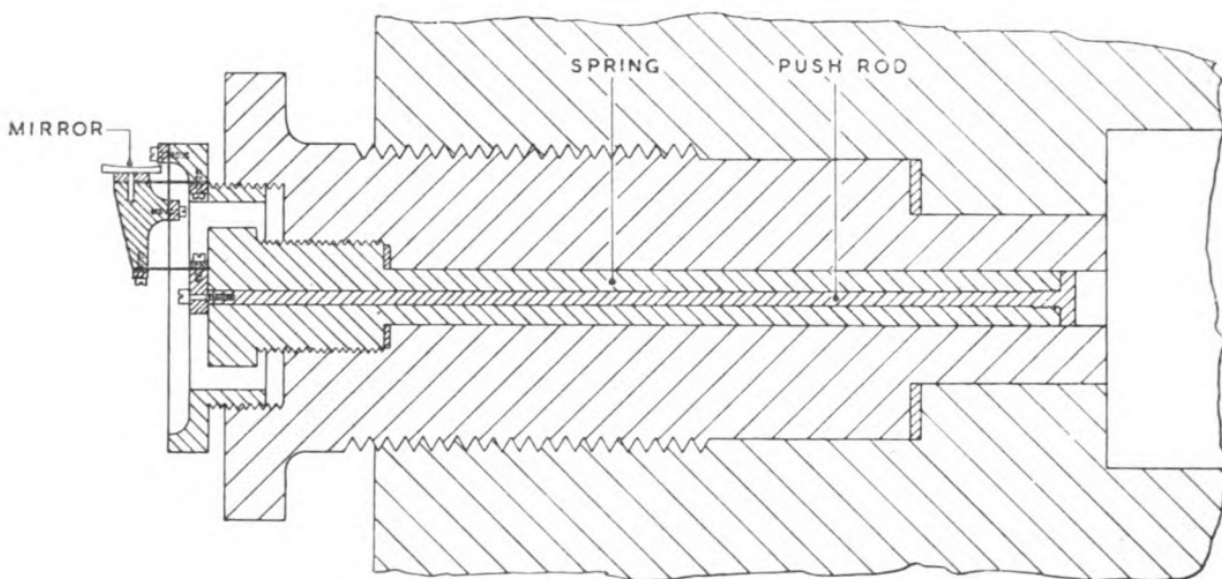

Fig. 13.09. A.R.E. spring gauge, second design.

The most recent type of mechanical gauge is shown in Fig. 13.10. One end of the rod screws into the piston-head which, in turn, screws into the tubular part of the gauge body. The other end of the rod is shaped to carry and tension a flat steel spring. One end of this spring is rigidly fixed to the rod and the other end is attached to a shackle which passes through the end of the rod and is threaded for a nut. Thus clockwise rotation of the nut applies tension to the spring. A second flat spring is secured to two lugs which are integral with the gauge body. The two springs are in parallel planes but their axes are at right angles; they are connected by an arm holding a mirror. Pressure on the piston head compresses the tubular part of the gauge body. This compression is transmitted through the rod to the first spring;

* *Engineering*, Vol. 134, pp. 231-232 (1932).

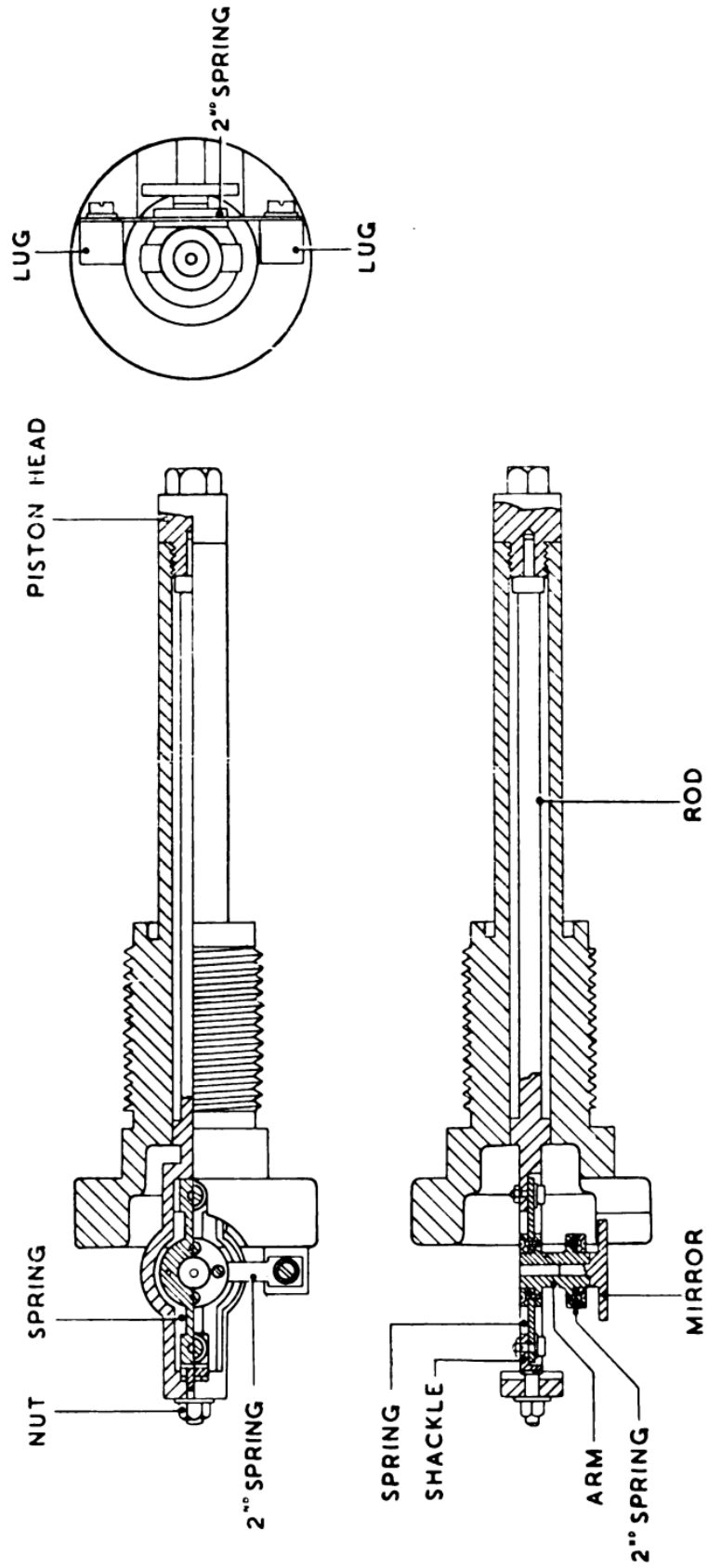

Fig. 13.10. High-pressure spring gauge.

the motion of this spring, which is connected to the second spring by the arm, rocks the mirror. One disadvantage of this design is that the relationship between pressure and angular rotation of the mirror is not linear.

The calibration of these gauges has been fully described in the papers to which reference has been made. Briefly, the method is to set up the gauge in the same way as for use in the closed vessel and to apply a series of known fluid pressures to the piston.

Records are made on a film attached to a revolving drum, the arrangement of the camera being quite conventional. The only unusual feature of the recording system is a method of obtaining a continuous time trace superimposed on the pressure record. An electrically-maintained tuning fork carries a concave mirror on one arm which is illuminated by light from the same slit as is used to give the main pressure trace. The reflected beam is brought to a focus on the front of the slit-plate itself, which is formed of a stainless-steel optical flat. The whole slit-plate is mounted in gimbals, and is set and locked in such a position that the beam of light from the fork mirror is reflected on to the gauge mirror and thence to the drum, where it forms a second image beside that which makes the pressure trace. Vibration of the fork causes the image of the beam from it to trace out a sine curve on the drum, and this follows the pressure trace throughout the whole time that the shutter is open. Usually only one side of the slit-plate is made to reflect, so that the peaks alone of this sine curve appear on one side of the line forming the pressure trace. An automatic relay is arranged to close the camera shutter as soon as possible after the maximum pressure has been recorded, so keeping the record clear of all but the essentials.

13.09. Recording of rate of pressure variation

It has been pointed out in Section 5.06 that there is considerable advantage in closed-vessel work in obtaining a record of the time-rate of pressure change rather than a pressure-time curve. If the output from the crystal of a piezo-electric gauge is passed through a resistance instead of a condenser, the current flowing through the resistance at any instant during the pressure rise is proportional to the rate of change of charge and therefore to the rate of change of pressure.

This method has been developed at the Burnside Laboratory of E.I. du Pont de Nemours and Company in the United States. The principle is employed in this country in an apparatus developed in the Armament Research Establishment of the Ministry of Supply in which the rate of pressure change is recorded against the pressure. A single crystal is used with this apparatus, half the output going to a condenser for pressure recording and the other half to a resistance for the recording of rate of pressure variation. The signals are, of course, amplified before they are applied to the two pairs of plates of a cathode-ray tube.

CHAPTER XIV

THE METHODS OF PROPELLANT PROOF

14.01. Objects of propellant proof

During the production of propellant of a given nature and size for a given gun, some of the processes will be carried out simultaneously on a number of similar machines ; these machines will not all be identical. When the demand is high, production may be proceeding simultaneously at a number of different factories, not only in the United Kingdom but possibly in one or more Dominions or foreign countries as well. At any given factory, or from any given machine, the properties of the propellant will change with the progress of time, either gradually (for example, as the pressing dies wear), or discontinuously (for example, when the source of supply of one of the raw materials, or some manufacturing process is changed). It follows that there will be differences in the properties of the finished propellant, as between the different machines in a given factory, as between different factories and with the progress of time ; these differences in properties will be reflected in differences in the ballistics of nominally similar samples of propellant made on different machines, at different factories, or at different times.

The effect of differences between machines at any given factory is minimised by *blending* the output from the machines, so that all the charges made up from the blended output are as nearly as possible ballistically identical and are representative of the mean output of all the machines. This blended output is divided, on the basis of the time of output, into *lots*, which are of such a size that they can be conveniently dealt with as a unit, but which are not so large that a material change in properties can be expected during the production of the lots. It follows that all charges made up to the same charge weight from a given lot should have identical properties, but differences may occur between charges made up from different lots, whether from the same or from different factories. The size of a lot varies from 5,000 to 50,000 pounds, largely as a matter of experience and expediency, and the number of rounds which can be filled from one lot of propellant varies from 90 with large naval guns to more than 40,000 with a QF 2-pr. Mark VIII gun. In an attempt to reduce the incidence and effect of lot-to-lot variations, the Royal Navy have recently introduced *super-lots* of 200,000 pounds formed by blending charges from four separate lots.

From each lot of propellant a sample is selected by the Inspection Department concerned (CIA. or CINO.), made up into a small number of rounds and *proved* by firing from the appropriate gun. The object of this propellant proof is four-fold :—

- (i) To ensure, by adjustments to the charge weight used for filling, if necessary, that the muzzle velocities realised on service with charges of any lot agree as nearly as possible with those of any other lot, and with the muzzle velocity which the user expects ;
- (ii) To ensure that the pressures set up when service charges are fired do not exceed the limits dictated by the design of the gun and projectile ;
- (iii) To act as a check on the production and to bring to light any trends or discontinuities in quality ;
- (iv) To ensure that the blending of the lot has been adequately carried out.

During the course of the proof of a lot of propellant, the muzzle velocity and maximum pressure are measured, using the procedure described in this Chapter, for each of a series of rounds : from these measurements are calculated, for both velocity and pressure, the *mean* for the series, and the *mean deviation* from the mean. The propellant proof specification lays down limits for some of these quantities, as follows :—

- (i) A maximum value for the mean deviation in muzzle velocity.
- (ii) A maximum and a minimum value for the mean pressure which would be achieved by a series fired at the adjusted charge weight (see Section 14.08).
- (iii) A maximum value for the pressure which would be achieved by the highest individual round of the series if fired at the adjusted charge weight.

No limit is laid down for the mean muzzle velocity : variations in this quantity are dealt with by adjusting the charge. (Section 14.08).

The appropriate Inspection Department also examines samples of all lots for correctness of dimensions, density, and chemical and physical properties.

14.02. Difficulty of propellant proof

The main object of propellant proof is to obtain an accurate measure of the ballistics (muzzle velocity, mean and maximum pressure) which will be given by a lot of cordite under certain as yet unspecified standard conditions in a given gun. The difficulty of attaining accuracy is due to the fact that, even with one lot of cordite, the measured ballistics vary from round to round, from day to day, and from gun to gun : the effects of gun erosion on ballistics may vary widely with different natures of propellant, and to a less extent from one gun to another : and, owing to the small ratio which the weight selected for firing bears to the weight of the propellant lot, a further error is introduced due to random sampling whereby the sample will not be exactly representative of the whole. It follows that every step in propellant proof is subject to error, and the method of proof adopted should be devised to reduce to a minimum the error in the final result for a given expenditure of ammunition.

14.03. Nature of variations

Round-to-round variations of ballistics in a series are of three kinds : those which are random and due to a large number of small random causes ; those which affect only the first round or part of a series ; and those which are progressive through the series.

The truly random variations are due to such causes as round-to-round variations in charge weight, in the mean size or composition of the propellant sticks or grains, in the temperature of the charge, in the ramming, in the weight of the projectile, in the driving-band resistance, in the use of the devices for the measurement of muzzle velocity and pressure, and in other factors which affect the ballistics. At all firings on which propellant proof depends, precautions are taken to reduce these causes to a minimum, but there is a minimum value for any given combination of gun, projectile and charge below which the representative value of the mean difference in velocity and pressure cannot be reduced : for most guns this value does not vary materially as the gun wears until towards the end of the life of the gun, when the variations increase, generally suddenly : when this occurs, the gun has passed the stage at which it can be used for reliable ballistic firings.

The ballistics of the first round of a shoot, fired from a cold gun, usually differ materially from those of the rest of the series : similarly, if, during a shoot, a change is made in the nature, size, or sometimes even charge temperature of the propellant, the first round after the change frequently differs in ballistics from the rest of the series. The reason for these phenomena is not well understood. The effect is, however, removed by neglecting the ballistics of the first round of a shoot (the *warmer* or *conditioning round*) and of the first round after a change of nature, size, or weight of propellant (the *anti-interference round*).

In certain equipments, the *interference* effect referred to above persists for more than one round : such cases partake more or less of the nature of variations which are progressive through the series. In guns which are designed for a medium velocity but have in addition a low velocity charge, the velocity of the first three or four rounds of a low velocity series fired immediately after a full charge series from the same gun will sometimes rise progressively

towards the representative value : examples are the lowest charge of the QF 25-pr. gun, or the obsolete, burst-short, practice charge of the QF 3.7-inch Mark I and II. Propellant proof in such cases presents particular difficulties but, up to the present, this has only occurred with charges where accurate determination of ballistics is, for some reason or other, comparatively unimportant. Where a phenomenon of this nature is expected, it may be advisable to fire more than one warmer or anti-interference round.

The more normal type of variation, progressive throughout the series, is that due to the wear of the gun ; with all propellants, the muzzle velocity and pressure vary progressively to a greater or less extent throughout the life of the gun. In a shoot with a number of lots, this effect can be compensated by so arranging the order of firing the rounds that the middle rounds of each lot are, as far as possible, coincident.

If series with a given gun, charge and shot be fired on a number of different days (or even sometimes on the morning and afternoon of the same day), the differences between the means of the ballistics of the several series, corrected for the wear of the gun, are almost always greater than can be accounted for statistically by the round-to-round variations within the series : the causes of these occasion-to-occasion variations are quite unknown. This effect makes it essential that any shoot in connection with propellant proof must be completed on one *occasion*.

Recent trials have suggested that if a number of guns are fired on a number of occasions, the occasion-to-occasion variations are, at least in part, common to all the guns : this phenomenon, however, has no immediate application to the problems of propellant proof.

If series with a given charge and shot be fired from a number of nominally identical new guns, the differences between the means of the ballistics of the several series are greater than can be accounted for statistically by the round-to-round variations within the series. Further, if the various guns are made by a number of different makers, the mean ballistics of the guns tend generally to be grouped according to the gun makers. These *gun-to-gun* and *maker-to-maker* differences are probably due to small differences in the dimensions of the ordnance or in the surface finish of the shot seating and bore ; they tend to disappear rapidly as the guns wear and are finally swamped by increasing gun-to-gun variations due to random differences in wear.

The magnitudes of the different variations (round-to-round, occasion-to-occasion, and gun-to-gun) have been reasonably well established for a wide range of guns and natures of propellant. The combinations of these variations and their effects on the accuracy of propellant proof are examined statistically in Chapter XV.

14.04. Methods of propellant proof

With so many possibilities of variation and consequent error, it is difficult to devise a system of propellant proof which shall be reliable. In the United States this proof is based on the use of a *standard gun*, in which samples of occasional lots are fired as a check on ballistics : this system depends on the assumptions that the occasion-to-occasion variation is negligible, that the wear curve of the gun is known, and that all the ammunition components associated with the firing are either themselves standard, or cause no alteration in ballistics from those of the standard.

In the British Service, propellant proof is based on the use of a standard lot of propellant. The basic assumptions are that the ballistics of the standard lot do not change with the passage of time, and that, if two or more lots are fired from the same gun on any given occasion, any circumstance which alters the ballistics of the propellant will have the same effect on all the lots. An analysis of proof results carried out during the last war has shown the possibility

that this assumption may be untenable with some guns ; the variations from occasion-to-occasion in the differences between lots are greater than can be accounted for statistically by between-round variations : this is known as the Hymans effect. (See Section 15.11).

To reduce to a minimum the adverse effects which would follow from any discrepancy between the facts of the case and this assumption, all conditions should be as near as practicable to standard conditions ; for example, all cordite proof should be done at the same charge temperature on all occasions ; the guns should be the newest available ; and the standard should be of the same nature and size as the lots under proof.

The British procedure for propellant proof may be summarised as follows :—

- (a) Select a lot of the propellant of which the chemical composition and dimensions are satisfactory, and which is sufficiently *matured* to make subsequent changes in ballistics unlikely : this lot becomes the *master-standard* lot.
- (b) Establish the *absolute ballistics* of this lot by firing in a sufficient number of representative new guns under standard conditions.
- (c) Select a further lot of propellant, reliable and matured, as a *current standard* for day-to-day use, and determine the ballistics of this by comparative firing against the master standard.
- (d) Determine the ballistics of the lots of propellant under proof by comparative firings against the current standard.

14.05. Absolute ballistics. Master standardisation

By *absolute ballistics* of a lot of cordite we imply the means of the muzzle velocities, maximum pressures, and their mean deviations, obtained by firing series in a number of new guns selected to represent the average new gun, under specified standard conditions as regards charge weight, cartridge design, method of ignition, proof shot and band design, and charge temperature : they are determined at a specified standard *E.F.C.*,* usually between five and nine. The process of determining *absolute ballistics* is known as *master standardisation*.

For large naval guns of which large numbers in a new condition are only rarely available, and for which the gun-to-gun variation is generally small, the minimum number of guns used is three : with medium-calibre guns six are generally used : with small-calibre guns, eight, of which two or more should be drilled as *pressure barrels*.† As maker-to-maker variations may be sensible, the guns should be spread over as many makers as possible, in order to give a representative result.

Crusher gauges are used for measuring pressures (see Section 13.05). Guns of up to 3.7-inch calibre inclusive take one crusher gauge ; above 3.7-inch up to 12-inch inclusive, two ; above 12-inch, four ; the number of gauges is limited by the free space available in the chamber. Where there are two or more charges of the same propellant size for a given gun, pressures need only be measured with the highest charge : where there is more than one size of propellant for a multi-charge gun, pressures should be measured for the highest charge of each size.

Except where otherwise laid down by the ordering authority, the charge temperature for master standardisation is 80° F. For such firings the magazine temperature needs careful watching and charges are held at this temperature with a tolerance of $\pm 1^\circ$ F. in the heating chambers for the periods before firing sufficient to ensure that the propellant temperature is uniform and correct. The following times are typical of those at present used ; they are

* *E.F.C.* denotes the number of equivalent full charges already fired from the gun. See *Text Book of Service Ordnance* (1923), p. 153.

† In small guns, in which there is no room for crusher gauges, pressure is measured with an external gauge screwed into a hole specially drilled in the chamber wall (with a corresponding hole in the wall of the cartridge case). Barrels which have been drilled for this purpose are called *pressure barrels* (see Section 13.05).

varied from time to time with accumulated experience : in addition, maximum times are also laid down, to ensure that ballistics are not unduly affected by loss of volatile matter :—

| <i>Guns</i> | <i>Hours</i> | <i>Howitzers</i> | <i>Hours</i> |
|----------------------------|--------------|--------------------------|--------------|
| BL. 14-inch and above | 120 | BL. 18-inch | 96 |
| BL. 13·5-inch and 12-inch | 108 | BL. 12-inch and 9·2-inch | 54 |
| BL. 9·2-inch and 8-inch | 96 | BL. 8-inch | 36 |
| BL. 7·5-inch | 72 | BL. 7·5-inch and below | 18 |
| BL. and QF. 6-inch* | 54 | | |
| BL. 5·5-inch—QF. 3·7-inch* | 36 | | |
| QF. 25-pr. and below | 18 | | |

Master standardisation firings are important and the greatest care is necessary for reliable results : four independent measurements of velocity should be taken, also reliable coppers and crusher gauges should be used. In particular, the charge design, method of ignition, mark of proof shot and design of driving band, which are used at any standardisation, must be used at all subsequent ballistic firings with that standard, unless it has been quite clearly and definitely established that any change in ammunition components gives ballistics which are identical with those of the original at all stages of wear of the gun.

It is desirable that the ballistics of standards should be as near as possible to the *velocity of adjustment* (see Section 14.08 below) and that the specification charge weight at which the lot under proof is fired should, on the average, give the velocity of adjustment. In these circumstances the differences between the observed velocities of standard and of lots, and of both from velocity of adjustment, will be kept to a minimum in accordance with the principle laid down above. This will generally be ensured by making up the standard to an adjusted charge weight based on its previous proof results, but the firing of a few preliminary rounds to confirm the charge weight may be desirable.

Except with granular propellants, as soon as master standardisation is completed all the charges from the lot which are to be kept as master standards should be made up into charges with as little delay as possible using the same charge design as was used for the master standardisation firing ; they should be stored in air-tight containers. Granular propellants are only made up into charges when required for firing ; the bulk propellant should be stored in the sealed cans as provided, because there is by this means less chance of a change in ballistics due to evaporation of volatile matter.

14.06. Current standardisation. Comparative ballistics

We have seen that the process of master standardisation requires the use of a number of new guns, the provision of which requires special arrangements which are not always easily practicable : it is important, therefore, to conserve master standard rounds as much as possible ; in fact, the master standard is regarded as a reference for the future rather than as a standard for proof of production lots. As soon as master standardisation is completed, a *current standard* is made for this purpose, the ballistics of the current standard being found by reference to those of the master standard.

The procedure for finding the ballistics of a lot with reference to a standard is as follows :— After a preliminary series, if necessary, to find the charge weight of the lot which will give as nearly as possible the velocity of adjustment, a series composed of the lot and the standard is fired, round for round, in any gun of the nature in which the standard was established ; this

* The quoted minimum time is doubled for QF. fixed or separate-loading ammunition.

gun may be at any stage of wear within its cordite proof life. The standard is fired at the charge weight, and with the charge and ignition design used at standardisation ; the lot of which the ballistics are to be determined is fired at the charge weight determined or expected to give the velocity of adjustment, and the charge and ignition design may or may not be the same as that of the standard, but must be such as will eventually be used for filling. The muzzle velocities and maximum pressures of the standard and of the lot are then meaned : the second assumption of Section 14.04 (that any circumstance which alters the ballistics of the standard will have the same effect on the lot) is then applied : the correction necessary to bring the mean ballistics found with the standard to its standard ballistics is applied to the mean ballistics found with the lot to give the *comparative ballistics* of the lot.

For example :

| | |
|---|-------------------------------|
| The standard ballistics of a standard lot are | 1650 f.s. ; 13.5 tons/sq. in. |
| At a comparative firing, | |
| The standard lot, as fired, gave | 1620 f.s. ; 12.5 tons/sq. in. |
| The lot being proved gave | 1610 f.s. ; 12.3 tons/sq. in. |
| Correction to bring the observed ballistics of the standard to its standard ballistics, | +30 f.s. ; +1.0 tons/sq. in. |
| Applying this correction to the ballistics of the lot as fired, gives the <i>comparative ballistics</i> , | 1640 f.s. ; 13.3 tons/sq. in. |

Provided that the basic assumption holds, this method corrects in one operation for the conditions and error of the day and for the wear of the gun : the only other condition is that the gun has not passed the stage of wear at which it became inaccurate.

The propellant lot for use as a current standard is selected on the same basis as that for a master standard ; the comparative firings against the master standard, carried out as above, are repeated some five or six times, and meaned ; these firings need not be carried out in the same gun. Current standards are stored in the same way as master standards.

When the current standard is becoming exhausted, a new current standard is made in sufficient time to ensure that the new standardisation is completed before the old lot is finished. It is advisable to include rounds from the old standard in the new current standardisation, to provide a check on the stability of the ballistics of the former.

The process of interposing a current standardisation between master-standardisation and proof of the lots must introduce at least a small experimental error ; moreover, the long life that the process of current standardisation grants to master standards provides an occasion for the ballistics of the master standard to change with time. It has recently been proposed that current standards should be abolished and that master standards should be used direct for cordite proof, their ballistics being checked by firings in new guns at frequent, regular intervals. This procedure should give increased accuracy, but will demand a large number of new guns which may not always be available.

14.07. Propellant proof

When a sufficient number of lots of propellant of a given nature and size for a given gun are ready for proof (usually about four for medium calibre guns ; less when the volume of production is small), comparative firings are undertaken against the current standard. The procedure is the same as that described for current standardisation above, except that one round of each lot under proof is fired for each round of the standard ; the order of firing is arranged as in Section 14.03. The charge weights of the lots under proof are selected and laid down in the proof specification to give a muzzle velocity as near as possible to the velocity of adjustment ; that of the current standard is, of course, that given in the Record Sheet, for which ballistics are known. The result of cordite proof is that, for known charge weights of the lots under proof, and within the limits of accuracy imposed by the method, the ballistics

(muzzle velocity, pressure and their mean deviations) are known under standard conditions (charge temperature, charge design, ignition, with proof shot and gauges), these being the conditions under which the master-standard ballistics were obtained.

A specimen set of forms used in establishing standards and proving a lot of propellant will be found on pages 185-189. Form I is the firing report on a typical master-standardisation series in one gun. The results of these firings for all the guns of the master-standardisation are collected in the *Master Standardisation Record* of which Form II is a specimen ; this record, with any comments on the firing, is forwarded to the appropriate service authority for approval ; the only comment in this case drew attention to the fact that the results agreed with expectation, an outcome which is reflected in the good agreement between the mean muzzle velocity attained (2450 f.s.) and the velocity of adjustment (2449 f.s.). Form III is the firing report of one series in which a lot which had been previously selected as a current standard is fired comparatively against the master standard : it will be noted that this contains no reference to the state of wear of the gun nor of the air density correction ; these are not necessary as any correction due to either cause will be applicable to the ballistics of both lots, and will not affect the corrected ballistics of the current standard. The results of these firings for all the series of the current standardisation are collected in the record of which Form IV is a specimen. Form V is a specimen firing report on the proof of a production lot of propellant, in comparison with the current standard. It will be noticed that the charge design of the current standard is the same as that of the master standard, as these are the data on which the master standardisation was based, but that the charge design of the lot being proved differs as this must be the same as that which is to be used subsequently for filling ; any difference in ballistics due to differences in charge design is taken up by this method of correction.

14.08. Velocity of adjustment ; adjusted charges ; control charts

From the user's point of view the prime object of propellant proof is to ensure that the muzzle velocity realised in service from charges of any lot shall differ as little as possible from that realised by other lots, or as given by the range-table wear tables. Lots of propellant may therefore be *adjusted* if required ; i.e., charges are filled to a charge weight which is calculated, from the results of propellant proof, to give a standard velocity under standard conditions. This velocity is known as the *velocity of adjustment* and the standard conditions are :—charge temperature 80° F. ; average new gun ; with gauge and proof shot ; charge design and method of ignition as used for filling. The value of the velocity of adjustment is fixed arbitrarily, e.g. to give the highest velocity obtainable without exceeding the pressure limitations of the gun, or otherwise.

The velocity of adjustment can be corrected for the difference of ballistics, if any, between proof shot and shell (this difference is usually negligible at calibres above about 5 inches), for the presence of gauges, and for the difference between the charge temperature of the master standardisation (80° F.) and that used in the range table (60° F. for land service : 70° F. for Naval service). The result will be the muzzle velocity to be expected in an average new gun firing shell under range-table conditions, and is thus the origin of the range-table wear tables.

The comparative ballistics of a lot of propellant fired at the specification charge weight as found at cordite proof will probably differ from the velocity of adjustment ; the correction to charge weight to allow for this difference of muzzle velocity can be calculated by the method of Section 11.05. This correction is applied to the charge weight used at proof of the lot to give the adjusted charge of the lot which is the weight at which charges of that lot are filled. It follows that, within the accuracy of the process of standardisation and propellant proof, charges filled to adjusted charge weight will give the velocity of adjustment when fired with proof shot under standard conditions. Thus the first of the three objects of propellant proof

referred to in Section 14.01 (that the muzzle velocities realised on service with charges of any lot agree as nearly as possible with those of any other lot, and with the muzzle velocity which the user expects) is achieved.

As the proof proceeds of a series of lots of the same nature and size of propellant from the same factory, the adjusted charge weights are plotted on a *control chart* against lot number (assumed to be consecutive). The use of control charts in guiding manufacture and in reducing proof is described in Sections 15.07 and 15.13.

14.09. Breaks in ballistics

When a new master standard is made it is essential to fire comparative series of the new master standard against the old ; it sometimes occurs that the ballistics of the old standard, derived by this comparison, differ from the original master standard ballistics by more than can be accounted for statistically by the normal errors of the processes. When this occurs, it indicates a change in conditions ; either the ballistics of the propellant of the old master standard lot have changed with the lapse of time, or the guns used either in the original or later master-standardisation did not represent the average of new guns at the time, or there has been a change in the ballistics of new guns, or some other disturbing phenomenon has taken place. The exact cause of the discrepancy in any given case is frequently difficult to determine, and, in the absence of evidence to the contrary, it is usually assumed either that the guns used for one of the master standardisations did not accurately represent the average performance at the time or that there has been a gradual change of the ballistics of the old master standard.

This occurrence is known as a *break in ballistics*. Breaks in ballistics may be brought to light by firings of various natures other than a check of one master standard against another, e.g. a sudden change in adjusted charge weights coinciding with a change in current standard would point to a break in the master standard ballistics between two current standardisations.

The following may be quoted as an example :

| | |
|--|-----------|
| B.L. 6-inch 26-cwt. How : Velocity of adjustment | 1250 f.s. |
| Ballistics of first master standard, Lot A, when originally made | 1250 f.s. |
| Ballistics of second master standard, Lot B | 1255 f.s. |

At the comparative firing in a part-worn gun, the muzzle velocities as fired were :

| | |
|-------|-----------|
| Lot A | 1244 f.s. |
| Lot B | 1235 f.s. |

Hence, assuming that Lot B is correct as it has been the more recently master-standardised, the comparative ballistics of Lot A is 1264 f.s. which is 14 f.s. above its master standard ballistics.

If a Lot X had been recently proved against the first master standard, Lot A, and had given the following results :—

| | <i>As fired</i> | <i>Corrected</i> |
|---------------------|-----------------|------------------|
| | <i>f.s.</i> | <i>f.s.</i> |
| Lot A (M.S.) | 1220 | 1250 |
| Lot X (under proof) | 1211 | 1241 |

the charge adjustment which would have been allotted to Lot X to give the velocity of adjustment of 1250 f.s. would have been the charge equivalent of + 9 f.s.; but the actual velocity which would have been given under standard conditions by Lot A would have been 1264 f.s., and the true corrected velocity of Lot X would have been 1255 f.s. and the correct charge adjustment, the equivalent of — 5 f.s. Thus, adjusted charges of Lot X will give muzzle velocities 14 f.s. above the velocity of adjustment.

When a break in ballistics is suspected or confirmed, all firings, including especially any check firings of the suspect standard lot, are scrutinised, and such confirmatory firings which are considered necessary are carried out in an attempt to determine as accurately as possible the magnitude of the break, whether its onset was gradual or sudden, and if possible the date of its occurrence. When all available evidence has been analysed, a choice has to be made between two courses of action :—

- (a) If it is more important tactically that different lots should shoot together, rather than shoot to the range-table wear table, the velocity of adjustment of lots proved against the new master standard is changed by the amount of the break in ballistics.

In the example given above, if lot X had been proved against master standard lot B, the results (because in a comparative firing lot B fires 9 f.s. below lot A) would have been as follows :—

| | <i>As fired, f.s.</i> | <i>Corrected, f.s.</i> |
|---------------------|-----------------------|------------------------|
| Lot B (M.S.) | 1211 | 1255 |
| Lot X (under proof) | 1211 | 1255 |

and the previous charge adjustment of + 9 f.s. would give the new velocity of adjustment of 1264 f.s.

This course of action is known as *maintaining ballistics*. The underlying assumption is that the ballistics of the master standard have changed gradually. When this course is followed it is not generally necessary to pass any information to the user.

- (b) When the extent and date of onset of the break in ballistics can be exactly established, and more particularly when, as in anti-aircraft gunnery, it is more important tactically that lots should shoot accurately to the range-table wear table than that they should shoot together, the velocity of adjustment is not changed. Users should be told what lots have been incorrectly adjusted, and by how much they are expected to shoot above or below the wear table.

14.10. Checking of standards

It is now evident that, when a break in ballistics occurs, the charges issued to the Service are less accurate than the users have the right to expect ; it is therefore essential that all possible checks on ballistics are imposed in order to ensure that, if a break occurs, it is detected before it becomes serious in magnitude. Among the checks which may be applied are :

- (i) *Critical examination of all cordite proof results.* If the ballistics either of the standard or of the lot are unusual, the conditions must be scrutinised and, if practicable, some firings repeated, in an attempt to trace the cause. A mistake may have been made ; an unexpectedly large occasion-to-occasion variation may have occurred, or there may be a break in ballistics.
- (ii) *Checking all standards by regular firings in new guns.* These checks are carried out not less often than annually, and more frequently with propellants which are known to be comparatively erratic. The interpretation of the results needs care as gun-to-gun and maker-to-maker variations may be at a maximum with some types of new guns. It has been shown, however, that this is the least ambiguous of the methods available for checking standards.
- (iii) *Control guns.* A special gun can be kept for checking one nature of standard and must be used for no other purpose. This method is only of value if the wear

curve for the gun-propellant combination is well established. A *probability zone* must be calculated within which the ballistics as fired should fall. This method is used in the United States but in this country it is considered to be less reliable and accurate than new-gun check firings.

- (iv) *Wear curves.* The ballistics of all series fired with standards at cordite proof are corrected for (a) the difference between the velocity of the standard and the velocity of adjustment and (b) the difference between the pressure of the standard and the pressure that the standard would have given had the charge been adjusted to the velocity of adjustment. The corrected ballistics are plotted against the number of equivalent-full-charge rounds fired. This procedure ensures that, if there has been no abnormality, the velocity curve remains smooth through a change in current standard; discontinuities may, however, occur in such circumstances in the pressure curve.

Velocity and pressure will not necessarily fall steadily as wear progresses. In some combinations of gun and propellant the curves fall in a series of festoons: in others, both velocity and pressure rise during the early stages of the life of the gun.

As different propellants produce wear curves of different shapes, the curves obtained are only of value if a propellant proof gun is used for one nature of propellant only, and for this purpose it is most desirable to have a separate barrel for each nature of propellant, if the gun may use more than one.

When more than one gun has been worn out at propellant proof with one nature of propellant, a mean wear curve is obtained which is used as a standard against which subsequent proof wear curves are compared, thus giving an idea of the behaviour of the standard.

- (v) *Comparisons between standards.* If two standards of different age are maintained, a new one being made when the first attains its expected half life, it is possible that, if there is any drift in ballistics, this may proceed at different rates in the two and may be detectable on the wear curve of the cordite gun.
- (vi) *Control charts.* The control charts referred to in Section 14.08 may also provide a check on the ballistics of the standard; they are, however, not free from ambiguity as it is impossible without outside evidence to differentiate between a trend in the ballistics of the standard and a trend in propellant manufacture. Useful evidence is sometimes available when the same nature and size of propellant is being made at two or more factories and is proved against the same standard; if the control chart relevant to one factory shows a trend which does not appear on the other, it is probable that production is changing; if, however, both control charts have the same trend, it is probably the standard that is changing.
- (vii) *Closed-vessel tests.* At many checks of a standard a sample is taken and tested in a closed vessel for force constant and rate of burning (or quickness). This system suffers from the fact that the sample is very small and may not be representative; and, the technique at present available in this country is only sufficiently sensitive to detect changes which would cause a gross break in ballistics. The technique may, however, be capable of improvement. In the United States it is very widely used and relied on; for some natures a closed-vessel test is applied to every propellant lot, and proof in the gun is dispensed with except for occasional check lots.

14.11. New nature of propellant

In the early stages of the production of a new nature of propellant it is sometimes necessary to assess adjusted charges for filling before a standard has been made : it will therefore be necessary to prove these lots against a standard of another nature. The effect of gun wear on velocity may be expected to differ for the two propellants so that this procedure violates the basic assumption that variations from standard conditions have the same effect on the standard and on the lot under proof. Results will therefore contain an error which can, however, be reduced in magnitude by using a gun as little worn as possible. Care must be taken to fire anti-interference rounds after each change of nature of propellant. This procedure should be regarded as a make-shift and lots so proved should be re-proved against a standard of the correct nature when this becomes available.

14.12. Special proof procedure

Multi-charge howitzers. Where a howitzer has more than two charges of the same size of a given propellant, it is only necessary to prove and calculate adjusted charge weights for the top and bottom charge of each size ; adjusted charge weights for the intermediate charges can be interpolated, using the approximate method of computation in Section 11.06. A prerequisite is that accurate charge determination firings shall have been carried out with one lot of propellant for the velocities of adjustments of all the charges.

Cross adjustment. This method was devised in order to economise in propellant charges of large guns. With each nature of gun is associated a gun of about 4 to 5 inches calibre ; from the paste of each lot of propellant for the larger gun, a sample is pressed in a smaller size suitable for the smaller gun. The first few lots are proved in both guns, each with its appropriate size, and adjusted charge weights are deduced ; from these results a linear co-relation formula is calculated, to give the adjusted charge weight for the larger gun in terms of that of the smaller, and also the standard deviation of the error introduced by the process. When sufficient lots have been proved in both guns to reduce this error to an acceptable value, proof in the larger guns is discontinued, except for occasional lots as a check. This procedure may introduce errors due to differences in the rate of wear of the dies of the two sizes of propellant, and in the extent to which volatile matter is removed.

14.13. Miscellaneous definitions

We conclude this chapter with a number of definitions of terms used in connection with propellant proof.

Nominal charge weight. With any given gun, projectile and propellant there is a charge weight which has been determined or estimated for design purposes. This charge weight, which is known as the *nominal charge weight*, is that quoted in range tables and handbooks and stencilled on cartridge bags or cases and ammunition boxes. It does *not* necessarily indicate the actual filled weight of propellant.

Specification charge weight. It is sometimes found that the average run of adjusted charge weights in current supply differs considerably from the nominal charge weight. In these circumstances, for general purposes such as the calculation of the amount of cordite required to meet orders for filling or for use as samples to be fired at proof, a *specification charge weight* is agreed and used. This quantity has no service significance and is of no interest to the user ; its use, when applicable, avoids the necessity for altering the nominal charge weight, with consequent alterations to designs, publications, and the markings of cartridges and packages.

Range-table muzzle velocity. This is the velocity for which the range table is compiled and for which instruments are graduated. It is frequently fixed of necessity before a charge determination is carried out, and is intended to represent approximately the muzzle velocity which will be realised with a quarter-worn gun at the charge temperature (70° F. for Naval

Service ; 60° F. for Land Service) for which the range table is compiled, but it is generally rounded off to an even 50 or 100 f.s. The range-table muzzle velocity is not related directly to the velocity of adjustment, but the range table, or the calibration scales of instruments, provide a method for applying a correction for the difference between the former muzzle velocity and the velocity actually realised by the gun ; this latter quantity may be found either by calibration or from the range-table wear table of which the zero is directly related to the velocity of adjustment.

Velocity to be expected in a new gun at 60° F. (Naval Service : 70° F.).

This quantity is included explicitly in all range tables : it is the origin of the range-table wear table, and is the velocity which adjusted charges at the stated temperature should give with shell of standard weight in a new gun. It is derived from the velocity of adjustment by applying corrections for the difference in charge temperature, the difference in ballistics between proof shot and shell, and the absence of crusher gauges.

SUBJECT Master Standardisation of N/FQ/S. 198-054 RNC.4678 Book 347 Page 68

REPORT OF ROUNDS FIRED

Nature of Gun Q.F. 4.5" Mk. 3 S.L.(d) No. 3088 Wear (ins.) E.F.C. Barometer 30.48 ins. Trial No. 1701
 Maker R.G.F. Previous 3 Thermometer, W.B. 61 °F. Ref. P.901/42(2)
 Date and Place of Firing 22-6-43 Woolwich Present " D.B. 71 °F. W.332/43

T = .993 (= - 1 f.s.) (a)

| No. of Round | CHARGE | | | PROJECTILE | | | MUZZLE VELOCITY (f.s.) | | PRESSURE (tons sq. in.) | | REMARKS | | | | |
|--------------|-------------------------|-----------------|-----------|--------------------|-------------------|--------------------------|------------------------|----------------|--------------------------------------|----------------------------|---------|------|------|-------------|---|
| | Nature and Lot | Weight lb. ozs. | Temp. °F. | Primer | Cart-ridge design | Mark and Weight lb. ozs. | Design Number of band | Ramming Inches | As fired | Mean | | 1 | 2 | Mean | Absolute M.V. |
| 4 | N/FQ/S RNC 198-054 4678 | 13 -- 6 | 80° | E & P No. 14 Mk. 5 | NOD 6356 | Mk. 1 55 -- 0 | 6659/2 | 36.8 | 2444 2449 2445 2447 2447 | 2446 m.d. 1.6 (b) | 18.7 | 18.8 | 18.9 | 2445 (c) | Flash—Nil Smoke— more than Service |
| 5 | | | | | | | | | | | 18.4 | 18.4 | 18.4 | | |
| 6 | | | | | | | | | | | 18.7 | 18.7 | 18.7 | | |
| 7 | | | | | | | | | | | 18.5 | 18.7 | 18.7 | | |
| 8 | | | | | | | | | | | | | | | |

NOTES.—(a) is the correction to allow for the difference between the air density at the time of firing and the standard air density : it is an external ballistic correction. It is applied to (b) to give (c).
 (d) Separate loading.

MASTER STANDARDISATION RECORD

GUN :— Q.F. 4.5" Mks. 1, 3 and 4 S.L. V. of A. 2449 f.s.
 N/FQ/S 198-054 RNC 4678

| Date | Gun | Maker | Lot No. | STANDARD | | | No. of Rounds | CORDITE | | | |
|---|------|------------|---------|---------------|------|----|---------------|------------------------|--------|---------------------|-------------------------------------|
| | | | | No. of Rounds | M.V. | P. | | Comparative Ballistics | | Absolute Ballistics | |
| | | | | | | | | M.V. | P. | | M.V. (New Tables) (b) (± T) (c) |
| (a) 22-6-43 | 3088 | R.G.F. | | | | 5 | | | 2445 / | 1.6 | 18.7 |
| 23-6-43 | 4039 | R.G.F. | | | | 5 | | | 2452 / | 3.2 | 18.7 |
| 30-6-43 | 6626 | R.O.F. (L) | | | | 5 | | | 2439 / | 6.0 | 18.1 |
| 1-7-43 | 4169 | M.O.S. (D) | | | | 5 | | | 2455 / | 3.2 | 18.9 |
| 2-7-43 | 6623 | R.O.F. (L) | | | | 5 | | | 2462 / | 6.4 | 19.1 |
| 3-7-43 | 4168 | M.O.S. (D) | | | | 5 | | | 2448 / | 2.6 | 18.7 |
| Charge Propellant : N/FQ/S 198-054 Lot RNC 4678 Design : NOD 6356 Weight : 13 lb. 6 oz. Ignition : Primers E. & P. No. 14 Mk. 5 Shot : Mtk. 1 at 55 lb. banded DD/L/6659/2 2 Crusher Gauges per round were used. | | | | | | | | | 2450 / | 3.8 | 18.7 |

NOTES : (a) This line is extracted from Form I.
 (b) Indicates the particular air resistance law used for correcting from observed to muzzle velocity. (Chapter XII).
 (c) Indicates the air density correction has been applied.

FORM III

P. & O. No. : 9 (Revised)

REPORT OF PROOF OF CORDITE N/FQ/S. 198-054 LOT RNP. 715

Book No. 331 Page 114

Place Woolwich Barometer 30.49

In Q.F. 4.5" Mk. IV S.L. Gun No. 4018 (R.G.F.)

Date 24-2-44 Thermometer Wet 29 Dry 31 Charge Temperature 80° F. Rifling

THE METHODS OF PROPELLANT PROOF

| Case No. | No. of rounds | Charge (a) | | | Proj'le (a) | Velocity | | | Pressure | | | Remarks | | | | | | |
|----------|---------------|----------------|----------|-----------------------|-------------------------------|--------------|----------|------|----------|------|---|---------|---|------|--------|--|--|--|
| | | Nat : | Lot | Weight lbs. ozs. drs. | | Charge dsn : | As fired | Mean | Corr'd | M.D. | 1 | | 2 | Mean | Corr'd | | | |
| | 55 | N/FQ/S 198-054 | RNC 4678 | 13 6 0 | A Preliminary round was fired | | | | | | | | | | | | | |
| | 8 | | | | Mk. I | | | | | | | | | | | | | |
| | 61 | | | | 55 lb. Bd. | | | | | | | | | | | | | |
| | 4 | | | | DD/L/ | | | | | | | | | | | | | |
| | 7 | | | | 6659/2 | | | | | | | | | | | | | |
| | 70 | | | | Mk. V | | | | | | | | | | | | | |
| | 57 | | RNP. 715 | 13 7 0 | | | | | | | | | | | | | | |
| | 60 | | | | | | | | | | | | | | | | | |
| | 3 | | | | | | | | | | | | | | | | | |
| | 6 | | | | | | | | | | | | | | | | | |
| | 9 | | | | | | | | | | | | | | | | | |

NOTES : (a) The details of the charge and projectile of the master standard are the same as at the master standardisation firings (Forms I and II) : those of the current standard differ only in the lot number and charge weight.
 (b) Charge weight found in a previous firing to give as nearly as possible the same velocity as the master standard.
 (c) Mean velocity and pressure of the master standard as fired.
 (d) Master standard ballistics from Form II : in conjunction with (c) gives a correction of — 20 fs : — 0.9 tons.
 (e) Mean velocity and pressure of the current standard as fired.
 (f) Corrected mean velocity and pressure of the current standard, found by applying the correction at (d) to the results (e).
 (g) Corrected pressure of the highest round of the series.

STANDARDISATION RECORD

V. of A. 2449 f.s.

Approved Ballistics 2450 f.s./18.7 tons/sq.in.

GUN :— Q.F. 4.5" Mk. IV S.L.

M/S Ballistics N/FQ/S 198-054 R.N.C.4678

(a)

| Date | Gun | Maker | Lot No. | STANDARD | | | CORDITE | | | | |
|---|------|--------|-------------|---------------|-----------------|-------------|---------------|------------------------|-------------|---------------------|---------------------------------|
| | | | | No. of Rounds | M.V. | P. | No. of Rounds | Comparative ballistics | | Absolute ballistics | |
| | | | | | | | | M.V. | P. | | M.V. (New Tables) (\pm T) |
| 24-2-44 | 4018 | R.G.F. | RNC 4678 | 6 | 2470/5.7 (b) | 19.6 (b) | 5 | 2450/6.0 (c) | 18.2 (c) | | |
| 15-3-44 | " | " | " | 6 | 2465/6.0 | 19.6 | 5 | 2441/3.6 | 18.0 | | |
| 25-5-44 | " | " | " | 6 | 2450/5.2 | 18.1 | 5 | 2439/0.6 | 18.4 | | |
| 26-9-44 | " | " | " | 6 | 2432/4.2 | 17.7 | 5 | 2438/4.2 | 18.1 | | |
| 10-1-45 | " | " | " | 6 | 2432/7.0 | 18.1 | 5 | 2443/5.6 | 18.3 | | |
| Particulars of Ammunition. (e) | | | | | | | | | | | |
| Propellant : N/FQ/S 198-054 R.N.P. 715 Ch. Wt. 13 lb. 7 oz. 0 dr. | | | | | | | | | | | |
| Design : N.O.D. 6356 | | | | | | | | | | | |
| Ignition : Primers E. & P. No. 14 Mk. V. | | | | | | | | | | | |
| Projectile Mk. I 55 lb. Bd. DD/L/6659/2 | | | | | | | | | | | |
| <p>NOTES : (a) Details and approved ballistics of the master standard, from Form II. (b) Ballistics (mean muzzle velocity and its mean deviation, and mean pressure) of the master standard, as fired, from Form III. (c) Mean corrected ballistics of the current standard, from Form III. (d) Accepted ballistics of the current standard. (e) Particulars of the current standard.</p> | | | | | | | | | | | |

FORM V

P. & O. No. 9 (Revised)

REPORT OF PROOF OF CORDITE

N/FQ/S. 198-054

LOT

RNC. 6264

Book No. 331

Page 138

Place Woolwich

Barometer 30.25

In Q.F. 4.5" Mk. IV S.L.

Gun No. 6827

R.O.F.L.

Date 25.9.45

Thermometer Wet 49

Dry 51

Charge Temperature 80°

F.

Rifling

| Case No. | No. of round | Charge | | Proj'le | Velocity | | Pressure | | Remarks | |
|----------|----------------|------------|-----------------------|-------------------------------|--------------|----------|----------|--------|----------|---|
| | | Lot | Weight lbs. ozs. drs. | | Charge dsn : | As fired | Mean | Corr'd | | Mean |
| 87 | N.FQ/S 198-054 | R.N.P. 715 | 13 7 0 | A Preliminary round was fired | 2455 | 2442 | 5.3 | 18.5 | 18.2 | Flash—Nil. Smoke— much more than service, all rounds. |
| 91 | | | | Mk. I | 2455 | 2442 | 5.3 | 18.5 | 18.2 | ADJUSTED CHARGE SAME GUN For use with 4 oz. Igniter |
| 5 | | | | 55 lb. Bd. | 2460 | | | | | |
| 9 | | | | DD/L/ | 2459 | | | | | |
| 103 | | | | G.12 | 2445 | | | | | |
| 7 | | | | 6659/3 | 2461 | | | | | |
| | | | | S/I. | 2448 | | | | | |
| | | | | (a) | | | | | | |
| 90 | | RNC 6264 | 13 7 0 | No foil Prim. | 2450 | 2441 | 3.6 | 18.6 | 18.3 (c) | PRESSURE MEAN 18.4 MAX. 18.9 |
| 4 | | | | E. & P. | 2460 | | | 19.0 | 18.7 (d) | |
| 8 | | | | No. 14 | 2456 | | | | | |
| 102 | | | | Mk. V (a) | 2455 | | | | | |
| 5 | | | | W.M. Lids | 2449 | | | | | |
| | | | | No foil Prim. as above. | | | | | | |

NOTES : (a) Particulars of ammunition the same as at current and master standardisations (Forms II and IV).
 (b) Corrected ballistics of current standard, i.e., the accepted ballistics from Form IV.
 (c) Corrected mean ballistics of the lot under proof, obtained exactly as in Form III.
 (d) Corrected pressure of the highest round, obtained as in Form III.
 (e) Adjusted charge weight, obtained from the weight of charge fired, with an allowance for the difference between the mean corrected velocity (2441 f.s.) and the velocity of adjustment (2449 f.s.; Forms II and IV).
 (f) Mean and maximum pressure at the adjusted charge weight.

D.P. & E.O.

Date.....

CHAPTER XV

STATISTICAL METHODS AND THEIR APPLICATION TO INTERNAL BALLISTICS

15.01. The application of statistical methods to tracking down and minimising variations in muzzle velocity and maximum pressure began in 1942 when a paper* was submitted to the Scientific Advisory Council of the Ministry of Supply, drawing parallels between the problems of proof and experimental ballistics and those of mass production, and suggesting that the statistical methods then being applied in industry should be operated on the proof ranges. The year 1943 and subsequent years saw the publication of papers discussing different aspects of the applications of statistics to ballistic firings and in particular to cordite and gun proof. Some of the more important points in these papers are discussed in this chapter.

The aims of all ballistic firings are either to improve accuracy in shooting or to ensure safety in the firing of the gun. Internal ballistic firings naturally direct attention towards muzzle velocity and pressure, and it is these quantities which are now to be analysed statistically. As far as safety is concerned, the ballisticians are interested only in the maximum pressure on which little analysis has as yet been done. The position is different for muzzle velocity. Regularity in muzzle velocity is of great importance in improving accuracy. There are inevitably variations present in ammunition, and these in turn must lead to chance variations from round-to-round in muzzle velocity. There are also variations which can be attributed to special causes as for example charge temperature and state of wear of the gun. Statistical methods are used to separate and measure these variations. The relative importance of the variations then becomes apparent and the ballisticians can see which require his attention. The remainder of this chapter refers only to muzzle velocity although most of the techniques described are quite general and could be applied also to maximum pressures.

15.02. The types of problems which statistical methods can help to solve

The ballistic problems to which statistics can help to provide the answer may be divided into five main headings. These are given below, together with examples and the name of the technique which affords the solution of the particular problem. The techniques are described in Sections 15.04—15.08 inclusive.

SIGNIFICANCE OF DIFFERENCES. This is best illustrated by an example. A new type of propellant is being tried out. Only a little of this propellant has been made because it has to be made on an experimental plant with a very limited capacity, and in fact there is hardly enough propellant for five rounds of ammunition. The five rounds are therefore fired under controlled conditions against a six round series of a standard lot of propellant of known characteristics. From the result of the firings of these rounds it has to be decided whether the muzzle velocity of the experimental ammunition is *really* higher (or lower) than that of the standard ammunition, and the variations in muzzle velocity of the experimental ammunition are *really* greater (or less) than those of the standard ammunition; and in both cases, what is meant by the word *really*?

Statistical tests have been devised to provide the answers to these questions. The test which is applied to the first is called the *F-test* and that applied to the second is called the *t-test*.

* J. R. Womersley : *A Statistical Analysis of measurements of muzzle velocity and maximum pressure at cordite proof and at gun proof*. R.D./Ball Report 23 42.

CORRELATION OF TWO OR MORE VARIABLES. The following two examples show the types of problem which arise :—

Five guns have been fired and the muzzle velocities and wear at one inch from the commencement of rifling have been measured at regular intervals throughout their lives. If the muzzle velocities are plotted against the equivalent full charge (E.F.C.) values, what is the best straight line which can be drawn through the points? Also what will be the error involved in the estimation, from this line, of muzzle velocities corresponding to any given E.F.C. values? Finally, if wear measurements were used instead of E.F.C. values, would the estimate of muzzle velocity become any more accurate? The finding of the line, and of the answers to the other two questions are part of the technique of *regression analysis*.

A rather more complicated problem for which regression analysis is used is the production of cross-adjustment formulae (see Section 14.12). It is required in each case to determine the formula which will give the best estimate of adjusted charge for a given gun and charge, without a firing proof, working only from cordite inspection data and firing results in another gun or at another charge weight. Regression analysis sorts out the variables, shows their relative importance, produces the cross-adjustment formula, and provides a measure of the error of estimate.

ANALYSIS OF VARIATIONS. Probably the commonest example can be found in routine cordite proof firings, in which five rounds from each of four lots of propellant are fired alternatively with six standard rounds at cordite proof and the muzzle velocities accurately measured.

Assuming that these propellant lots are so similar in nature that they may all reasonably be assumed to produce equally regular ballistics, there are three types of variation which go to make up the variation from round-to-round during proof. There are lot-to-lot variations, systematic variations related in some way to the serial number of the round, and chance variations inherent in the nature of the gun and ammunition. These can be separated and their relative importance measured by means of the *analysis of variance*.

CONTROL OF QUALITY. From statistical analysis of the detailed information available from a large number of cordite proof firings trends in manufacture quickly become apparent, and when this information is set out graphically the results are even more obvious. By statistical analysis it is possible to set limits on these graphs outside which the cordite proof results must not fall if a certain standard of accuracy is to be maintained. When the trend shows that future results will inevitably fall outside the permissible limits, action is taken to ensure that a return to acceptable quality is made as quickly as possible. This is the *control chart* technique which was applied extensively by the engineering industry to mass production during the War.

SPECIFICATIONS. The use of the analysis of variance and of control charts makes much fuller information available on the quality of propellant. With this information, the *specifications* for proof and acceptance can be modified and greater control is thus obtained over the product of the propellant factories.

15.03. Definitions of statistical terms

In this and the four subsequent sections brief definitions of statistical terms and descriptions of statistical techniques are given. For further and more detailed study the reader is referred to any standard work on statistical methods.*

POPULATION AND SAMPLES. These are best illustrated by an example. Propellant is manufactured in lots and in general a complete lot is used to make charges for a specific kind

* See, for instance, *Statistical methods in research and production*, edited by O. L. Davies, published by Oliver and Boyd (1947).

of ammunition. All these charges are made to the same design and charge weight and they have therefore the nature, design and weight in common.

To assist the manufacturers certain variations from the design weight are permitted. If an inspector wishes to know in detail the sizes of these variations in a particular lot of 10,000 charges he is faced with the prospect of weighing accurately all of them. The 10,000 weights, whether they are measured or not, make up a *population*. The general concept of a population is that of the collection of the measurements of a particular attribute of each of a group of individuals having something in common.

It is rarely desirable to measure all the individuals in the population, and indeed, in much ballistic work, since each measurement involves destruction of ammunition, it is very important to use the smallest possible number of observations which will give a fair estimate of the qualities of the population. The two qualities about which information is generally required are the *average* (or mean) and the *variability* (or dispersion about the mean). In practice this information is found by selecting a small but representative *sample* and measuring the quality being investigated. Clearly this answer will give only *estimates* of the mean and variability of the population.

Suppose that there are n individuals in the sample and that the relevant measurement of the first individual is x_1 , of the second is x_2 , and so on. The *sample mean* is given by the equation

$$\bar{x} = (x_1 + x_2 + \dots + x_n)/n$$

The modern measure of the dispersion in the sample is the *variance* which is the average of the squares of the individual deviations from the sample mean :—

$$\text{Sample Variance} = \{(x_1 - \bar{x})^2 + (x_2 - \bar{x})^2 + \dots + (x_n - \bar{x})^2\}/n$$

The square root of the variance is called the *standard deviation*, and it also is used extensively as a measure of dispersion. It has the advantage that it is always measured in the same units as the original observations.

The variance is widely used nowadays because it is simpler to manipulate than the standard deviation. For example, the variance of the sum of a number of independent variables is equal to the sum of the variances. If $V(x)$ denotes the variance of x and $V(x + y + z + \dots)$ denotes the variance of the quantity produced as a result of summing independent variables x, y, z and so on, then

$$V(x + y + z + \dots) = V(x) + V(y) + V(z) + \dots$$

This is of great importance in the analysis of variance (to be described later).

To find the standard deviation of the sum of a number of independent variables involves the squaring of standard deviations, adding them and finding the square root—a rather laborious process. The same is also true of the mean deviation. (See Section 15.09).

DEGREES OF FREEDOM. This is a most difficult concept which may be best understood by considering an example :—

A particular lot of propellant is made up into charges all of the same adjusted charge weight (within limits). The *precise* weight of any charge will not have any connection with the *precise* weight of any other charge apart from the general approximate agreement with the common adjusted charge weight. If a sample of n charges is selected, the charge weights of these n charges will be independent in the above sense. If now the deviations of these n weights from the mean weight of the sample are calculated, there will only be $n-1$ independent quantities. This can be understood by considering the equation for the mean in the following form :—

$$n\bar{x} = x_1 + x_2 + \dots + x_{n-1} + x_n$$

If \bar{x} is fixed, $(n - 1)$ of the weights can be varied in any manner, but the last one can only have the one value which will make both sides of the equation balance. In other words only $(n - 1)$ of the weights are free to move, and the set of deviations is said to have $(n - 1)$ *degrees of freedom*. The n original weights, all being independent, had n degrees of freedom.

In general, if there are m samples of each of n observations, the deviations of all the measurements from their own sample means will have $m(n - 1)$ degrees of freedom, the sample means themselves having the other m degrees of freedom to account for all the mn measurements.

POPULATION ESTIMATES. Generally the sample variance and mean are not of themselves important. Their real use is to provide the best estimates of the variance and the mean respectively of the population from which the sample comes.

The best estimate of the mean of the population is the mean of the sample, but the best estimate of the variance of the population is not the variance of the sample. This is because the mean of the sample itself can vary and in fact has a variance. The best estimate of the population variance is the sum of the squares of the deviations divided by the degrees of freedom in the sample. The formula for an estimate based on a sample of n observations is

$$\text{Population variance} = \{(x_1 - \bar{x})^2 + (x_2 - \bar{x})^2 + \dots + (x_n - \bar{x})^2\} / (n - 1)$$

In the analysis of variance the rule is, to find the estimate of the population variance divide the sum of squares of the deviations by the relevant number of degrees of freedom.

15.04. Significance tests ; the F-test and the t-test

In the normal problem there are two populations from each of which a small sample has been selected at random and it is required to discover from these two samples whether for all practical purposes the variability and average values of the two populations are *really* different.

Suppose that the first sample consists of n measurements designated by $x_1, x_2, x_3, \dots, x_n$, and the second sample of m measurements designated by $y_1, y_2, y_3, \dots, y_m$.

The average of the first sample is given by the equation

$$\bar{x} = (x_1 + x_2 + \dots + x_n) / n$$

and of the second sample by

$$\bar{y} = (y_1 + y_2 + \dots + y_m) / m$$

The estimates of the population variance are given by

$$\begin{aligned} V_1 &= \{(x_1 - \bar{x})^2 + (x_2 - \bar{x})^2 + \dots + (x_n - \bar{x})^2\} / (n - 1) \\ &= \{x_1^2 + x_2^2 + \dots + x_n^2 - n\bar{x}^2\} / (n - 1) \end{aligned}$$

and similarly

$$V_2 = \{y_1^2 + y_2^2 + \dots + y_m^2 - my^2\} / (m - 1)$$

and it is assumed that V_1 is greater than V_2 .

The difference in the variability is investigated by the F-test by comparing $F (= V_1/V_2)$ with the figures in the table of the Variance Ratio (Table 15.01) corresponding to the values of $m - 1$ and $n - 1$

If the ratio F is less than that in the sub-table headed "0.20 significance level," a larger ratio than that found would, over a long series of such experiments, occur in at least one-fifth

of them, while if the ratio is more than that in the sub-table headed "0.001 significance level," *on the average* over a thousand trials would need to be done before a larger ratio could be found. In the first case the variabilities in the two samples are to all intents and purposes the same, while in the second they are quite different. The two other sub-tables are there to measure intermediate degrees of difference.

The difference in the average values of the two populations is investigated by finding the difference between the sample means and comparing it with the theoretical standard deviation of the difference of means of samples, one of m individuals and one of n individuals, from the two populations combined.

The difference between the sample means may be written $|\bar{x} - \bar{y}|$ while the standard deviation of the difference, which will be designated by $\sigma(d)$, is

$$\sigma(d) = \left[\left\{ \frac{(n-1)V_1 + (m-1)V_2}{n+m-2} \right\} \left\{ \frac{1}{n} + \frac{1}{m} \right\} \right]^{\frac{1}{2}}$$

The ratio of the difference to the standard deviation is designated by the letter t so that

$$t = |\bar{x} - \bar{y}| / \sigma(d)$$

The columns in Table 15.02 correspond to the sub-tables in Table 15.01 and the significance of any value of t is found by comparing the value found with the tabular values for $n + m - 2$ degrees of freedom.

A numerical example which illustrates the technique is as follows :—

6 standard rounds are fired alternately with 5 rounds of experimental ammunition in the Q.F. 25-pounder.

The velocities are as follows :—

| STANDARD AMMUNITION | | | EXPERIMENTAL AMMUNITION | | |
|---------------------|----------|----------------------|-------------------------|----------|----------------------|
| Round No. | M.V. f/s | Difference from 1495 | Round No. | M.V. f/s | Difference from 1503 |
| 2 | 1502 | + 7 | 3 | 1508 | + 5 |
| 4 | 1488 | — 7 | 5 | 1505 | + 2 |
| 6 | 1500 | + 5 | 7 | 1502 | — 1 |
| 8 | 1496 | + 1 | 9 | 1496 | — 7 |
| 10 | 1498 | + 3 | 11 | 1504 | + 1 |
| 12 | 1486 | — 9 | | | |
| Mean | 1495 | + 16 — 16 = 0 | Mean | 1503 | + 8 — 8 = 0 |

The problems to be solved are :—

1. Is the experimental ammunition *really* more regular than the standard ?
2. Is the experimental ammunition *really* 8 f/s or more higher than the standard ?

The variances are :—

Variance of standard

$$= \frac{1}{5} [(+ 7)^2 + (- 7)^2 + (+ 5)^2 + (+ 1)^2 + (+ 3)^2 + (- 9)^2] = 42.8 (f/s)^2$$

Variance of experimental ammunition

$$= \frac{1}{4} [(+ 5)^2 + (+ 2)^2 + (- 1)^2 + (- 7)^2 + (+ 1)^2] = 20 \text{ (f/s)}^2$$

PROBLEM 1. Is the experimental ammunition *really* more regular than the standard?

$$F = 42.8/20.0 = 2.14$$

From Table 15.01 it appears that a F-ratio of greater than 2.14 will happen by chance about once in five experiments if the two series (of 6 and 5 rounds) were actually derived from the same population.

The answer to problem 1 is that the experimental ammunition has not proved itself, from this trial, to have been more regular than the standard. If, however, 40 rounds of each variant had been fired and the F had been 2.14 it would have been correct to deduce that the experimental ammunition was more regular, because such a thing would happen by chance only once in more than 100 trials. If the point is an important one a much more extended trial is therefore necessary.

PROBLEM 2. Is the experimental ammunition really 8 f/s (or more) higher than the standard?

$$\sigma(d) = \left[\left(\frac{214 + 80}{4 + 5} \right) \left(\frac{5 + 6}{5 \times 6} \right) \right]^{\frac{1}{2}} = 3.46$$

$$t = 8/3.46 = 2.312$$

From Table 15.02 for 9 degrees of freedom if $t \geq 2.312$ it can be deduced that a difference at least as large would appear by chance once in 20 times if the whole series of 11 rounds had been selected from the same type of ammunition.

It is thus fair to deduce that there is a real difference in the mean muzzle velocity but to confirm it the trial should be repeated.

15.05. Regression analysis

There are two problems involved here. If we have a series of velocities plotted against wear or E.F.C. values, what is the straight line which can be drawn most closely through the points and what is the measure of the variation of these points from the line?

Normally a large number of points would be available, but to simplify the calculations, only 10 points will be taken in the example below.

The following are 10 muzzle velocities each representing the mean of a 6-round series set against the E.F.C. value corresponding to the first round of each series.

| | E.F.C. value | M.V. in f/s. |
|------|--------------|--------------|
| | 50 | 2810 |
| | 106 | 2783 |
| | 143 | 2762 |
| | 201 | 2770 |
| | 254 | 2720 |
| | 310 | 2719 |
| | 348 | 2688 |
| | 397 | 2646 |
| | 449 | 2674 |
| | 502 | 2638 |
| Mean | 276 | 2721 |

Call the E.F.C. value x and the muzzle velocity y . The individual values of x and y are subtracted from the mean values to simplify the arithmetic, and the analysis is as follows :—

| δx | δy | $(\delta x)^2$ | $(\delta y)^2$ | $\delta x \delta y$ |
|------------|------------|----------------|----------------|---------------------|
| — 226 | + 89 | 51076 | 7921 | — 20114 |
| — 170 | + 62 | 28900 | 3844 | — 10540 |
| — 133 | + 41 | 17689 | 1681 | — 5453 |
| — 75 | + 49 | 5625 | 2401 | — 3675 |
| — 22 | — 1 | 484 | 1 | + 22 |
| + 34 | — 2 | 1156 | 4 | — 68 |
| + 72 | — 33 | 5184 | 1089 | — 2376 |
| + 121 | — 75 | 14641 | 5625 | — 9075 |
| + 173 | — 47 | 29929 | 2209 | — 8131 |
| + 226 | — 83 | 51076 | 6889 | — 18758 |
| Totals 0 | 0 | 205760 | 31664 | — 78168 |

$$\sigma_x = \left(\frac{205760}{10} \right)^{\dagger} = 143.4$$

$$\sigma_y = \left(\frac{31664}{10} \right)^{\dagger} = 56.27$$

If n is the number of pairs of observations, the mean product deviation

$$= \Sigma \delta x \delta y / n = -7816.8$$

Coefficient of correlation,

$$r = \Sigma \delta x \delta y / n \sigma_x \sigma_y = -.9687$$

The answers to the questions above are respectively : the straight line which can be drawn most closely through these points is given by the equation

$$(y - \bar{y}) / \sigma_y = r (x - \bar{x}) / \sigma_x$$

Substituting the above values leads to muzzle velocity

$$= 2826 - .38x \text{ f/s}$$

and the standard deviation of the observed muzzle velocities from the estimates of muzzle velocity by this formula is

$$\sigma_y \sqrt{1 - r^2} = 14.0 \text{ f/s.}$$

This result could also be obtained directly by finding the individual deviations of the observed muzzle velocities from the estimates of muzzle velocity by the first equation, summing their squares and taking the square root of the average.

The square of this figure is called the residual variance about the regression line of muzzle velocity on E.F.C. value.

15.06. Analysis of variance

Suppose that a current standardisation consists of five-round series of the master and current standards fired round for round on five different occasions. (Normally an extra standard round is fired (see Section 14.07), but the inclusion of this round would complicate the following discussion out of all proportion).

The following are the actual details of such a standardisation :—

Gun B.L. 6 inch Mk. XII

Propellant : SC 122

| Occasion | Master-Standard Velocities | | | | | Current-Standard Velocities | | | | |
|--------------|----------------------------|------|------|------|------|-----------------------------|------|------|------|------|
| | A | B | C | D | E | A | B | C | D | E |
| Round number | | | | | | | | | | |
| 1 | 2750 | 2740 | 2733 | 2725 | 2729 | 2750 | 2739 | 2738 | 2732 | 2729 |
| 2 | 2731 | 2726 | 2729 | 2734 | 2730 | 2743 | 2740 | 2741 | 2740 | 2730 |
| 3 | 2741 | 2730 | 2723 | 2727 | 2729 | 2750 | 2735 | 2743 | 2737 | 2736 |
| 4 | 2743 | 2727 | 2720 | 2730 | 2725 | 2745 | 2738 | 2733 | 2735 | 2729 |
| 5 | 2736 | 2728 | 2721 | 2730 | 2728 | 2744 | 2735 | 2740 | 2739 | 2729 |

The master-standard velocities will be analysed first.

To reduce the figures to manageable proportions, deduct 2735 f/s (approximately the average velocity of all 50 rounds) from all the velocities.

The master-standard table then becomes, with horizontal and vertical totals added and meaned :—

| Occasion | A | B | C | D | E | Totals of rows | Means of rows |
|-------------------|-----|------|------|------|------|----------------|---------------|
| Round number | | | | | | | |
| 1 | 15 | 5 | —2 | —10 | —6 | 2 | .4 |
| 2 | —4 | —9 | —6 | —1 | —5 | —25 | —5.0 |
| 3 | 6 | —5 | —12 | —8 | —6 | —25 | —5.0 |
| 4 | 8 | —8 | —15 | —5 | —10 | —30 | —6.0 |
| 5 | 1 | —7 | —14 | —5 | —7 | —32 | —6.4 |
| Totals of columns | 26 | —24 | —49 | —29 | —34 | —110 | —4.4 |
| Means of columns | 5.2 | —4.8 | —9.8 | —5.8 | —6.8 | —4.4 | |

The occasion-to-occasion variation, as measured by the variance of the occasion means with the number of occasions as denominator is

$$\frac{1}{5} \{ (5.2)^2 + (-4.8)^2 + (-9.8)^2 + (-5.8)^2 + (-6.8)^2 \} - (-4.4)^2 = 25.84 \text{ (f/s)}^2$$

The *systematic* round-to-round variation, as measured by the variance of the mean velocities of the rounds with the number of rounds per series as denominator is

$$\frac{1}{5} \{ (0.4)^2 + (-5)^2 + (-5)^2 + (-6)^2 + (-6.4)^2 \} - (-4.4)^2 = 16.064 \text{ (f/s)}^2$$

To find the *random* round-to-round variation, which is the total variation denuded of systematic occasion-to-occasion and round-to-round effects, the two variances just calculated are subtracted from the square of the deviation from the grand mean, of each velocity ; and the 25 observations are totalled as follows :—

$$\begin{aligned} & \{ [15 - (-4.4)]^2 - 25.84 - 16.064 \} + \{ [-4 - (-4.4)]^2 - 25.84 - 16.064 \} \\ & + \dots \dots \dots + \{ [-7 - (-4.4)]^2 - 25.84 - 16.064 \} \\ & = 120.4 \end{aligned}$$

The results are normally set out in a table of the following form :—

| Variation | Sum of squares | Degrees of freedom | Variance |
|-------------------|---------------------|--------------------|----------|
| Between occasions | 25.84 × 25 = 646 | 4 | 161.5 |
| Between rounds | 16.064 × 25 = 401.6 | 4 | 100.4 |
| Residual | 120.4 | 16 | 7.525 |
| Total | 1168 | 24 | — |

The degrees of freedom of the first two and the total are quite obvious—number in sample *minus* one, while the figure for the residual is the difference between the total number of degrees of freedom (24) and those already used (8).

The quotients are then estimates of the variance between occasions, of that between rounds, and of the residual variance (i.e. the remainder).

The variances in the above table may be tested by the F-test—if any such test is thought necessary in this case—and the first two will be found to be very significantly greater than the residual variance.

Both the between-rounds and the between-occasions variances include a component due to chance variation; this component is the *residual variance* mentioned above. It is the most reliable estimate of the fundamental variations associated with the gun and ammunition because it is not affected (as is the mean deviation) by systematic variations. It is, however, more cumbersome to compute. In symbols if V_D , V_R , and V_0 are the variance from occasion-to-occasion, the variance from round-to-round, and the residual variance respectively, and if σ_D , σ_R , and σ_0 are the standard deviations of the original populations from which the observations in the table were a 5 × 5 sample, and if n_D = the number of occasions and n_R = the number of rounds per series then

$$\begin{aligned} V_D & \text{ is an estimate of } n_D \sigma_D^2 + \sigma_0^2 \\ V_R & \text{ ,, ,, ,, ,, } n_R \sigma_R^2 + \sigma_0^2 \\ V_0 & \text{ ,, ,, ,, ,, } \sigma_0^2 \end{aligned}$$

and rearranging we have in the form of a table :—

| Variation | Standard deviation | Estimate | Numerical value |
|-------------------|--------------------|----------------------------|-----------------|
| Between occasions | σ_D | $\sqrt{[(V_D - V_0)/n_D]}$ | 5.5 f/s |
| Between rounds | σ_R | $\sqrt{[(V_R - V_0)/n_R]}$ | 4.3 f/s |
| Residual | σ_0 | $\sqrt{V_0}$ | 2.7 f/s |

The same analysis may be applied to the whole standardisation by first treating the current standard velocities as if they were further firings of the master standard, and then analysing the firings means to investigate whether the occasion of a particular firing affected the velocities of the master and the current standards in the same way, within the limits to be expected from random sampling. The results of this first stage are shown in the table below.

| Variation | Sum of squares | Degrees of freedom | Variance |
|-----------------|----------------|--------------------|----------|
| Between firings | 1973.7 | 9 | 219.3 |
| Between rounds | 104.2 | 4 | 26.0 |
| Residual | 620.6 | 36 | 17.2 |
| Total | 2698.5 | 49 | — |

The second stage is to regard the *between firings* figures as the total in a new table in which *between-occasions* and *between-lots* are analysed. In this case the residual (if any) will be a measure of the variation which cannot be attributed either to the lot alone or to the firing alone, that is to say the lot and firing affect each other in some unpredictable way. In statistical theory they are said to *interact* and the residual variance is in this case called the *interaction*. There are two other interactions (i.e. rounds × occasions and rounds × lots) which can be calculated but are not of importance in this example.

The results of the calculations are shown below.

| Variation | Sum of squares | Degrees of freedom | Variance |
|----------------------------|----------------|--------------------|----------|
| Between occasions | 1120.6 | 4 | 280.2 |
| Between lots | 684.5 | 1 | 684.5 |
| Occasion × lot interaction | 168.6 | 4 | 42.2 |
| Total | 1973.7 | 9 | — |

These two tables are normally combined in one table and the significance of the other variances and interactions tested against the original residual variance. In this example an interaction as large would have arisen by pure chance once in about 15 times, so that there is no evidence from these firings that there were any extraneous effects (see Section 14.04).

Interaction and correlation both involve the idea of variations which are in some way connected. The essential difference is that *correlation* implies the variation of one numerical variable with another, and the estimation of the value of the one within certain limits when the value of the other is given, whereas *interaction* implies that a numerical quantity under investigation is not only affected by certain conditions separately but also by them in conjunction.

15.07. Control charts

Under normal circumstances the manner in which the means of samples may vary can be predicted from examination of the internal variation within these samples. For example, suppose there are 20 samples of 5 measurements each from the same population. The best estimate of the population variance is given by

$$V = \frac{\text{Sum of squares of deviations from means of samples}}{20 \times (5 - 1)}$$

The variance of the means of samples of n drawn from this population is then V/n .

The means of samples are generally sufficiently nearly distributed normally (despite the shape of the parent distribution) to enable certain elementary deductions to be drawn: if the samples come from the same population, only one in 20 of the sample means will lie outside the region $\bar{x} \pm 2\sqrt{(V/n)}$ and only one in 500 of the sample means will lie outside the region $\bar{x} \pm 3\sqrt{(V/n)}$ where \bar{x} is the population mean. Again, if the sample means are so disposed that they do not agree with the above relationships either because the points are too scattered or too concentrated, it may be deduced that the samples do not come from the same population, and that the sample-to-sample variations are real, or that the parent population is far from being normally distributed.

In practice control charts are set up for the means of samples and for some measure of sample dispersion, e.g. standard deviation or mean deviation. As soon as each sample has been inspected, the mean and (say) mean deviation are found and plotted on the chart. As long as the results are disposed according to the first criterion above, and there is no clear trend up or down, the product is said to be *under control*. A trend or a concentration of points outside or even towards one of the limits, is regarded as an indication of a change in quality (the product is *out of control*) and as a warning that something must be done to bring the product back under control. These limits are called *action limits*.

15.08. Specifications

In every specification two things must be taken into consideration, the consumer's requirement and the practical limits to what the manufacturer can produce. Any specification must be a compromise between the two when the consumer really wants something better than any manufacturer can give him.

Ammunition demands the highest possible accuracy and specifications are normally drawn up as a result of the experience of the Inspection Departments. Once production is in full swing it is possible to reconsider the specifications with the aid of statistical analysis of inspection records, and if necessity should arise, either to amend the specification or, if that is not possible or desirable, to amend the manufacturing processes.

For a population having a Gaussian distribution, the specification limits might be taken as population mean $\pm 3\sqrt{(V/n)}$, corresponding to the 499-out-of-500 region, i.e. the outer action limits.

15.09. Mean deviation

The mean deviation is the measure of dispersion generally used for ballistic firings. It is used because it is very simple to calculate and although it is not so efficient a measure as the standard deviation, it is much better than the simpler *greatest difference* if the number of rounds in the series exceeds three. It is less efficient than the standard deviation in the sense that on the average it requires a larger sample to give an equally reliable measure of the dispersion of the population from which the sample (e.g. a five round series) is drawn. However, recent work has demonstrated that the mean deviation is more stable under varying population distributions than the standard deviation or the greatest difference. This may be of especial importance in ballistic firings.

Over a large number of samples there is a close connection between the size of the variance and of the mean deviation and some idea of this connection may be gleaned from the table below.

| Variance | Mean deviation for sample size | | |
|----------|--------------------------------|-----|-----|
| | 3 | 5 | 10 |
| 1 | 1.0 | 0.9 | 0.8 |
| 5 | 2.2 | 2.0 | 1.9 |
| 10 | 3.1 | 2.8 | 2.7 |
| 50 | 6.9 | 6.3 | 5.9 |
| 100 | 9.8 | 8.9 | 8.4 |

The mean deviation of the resultant of two independent variations is equal to the square root of the sum of the squares of the mean deviations of the variates.

In symbols,

$$m_{x+y} = \sqrt{(m_x^2 + m_y^2)}$$

It follows that if m_x and m_y are very unequal in size, the value of m_{x+y} will be very close to that of the larger of m_x and m_y . The table below shows this clearly, and it should be borne in mind when making deductions from the figures set out in Section 15.10.

| m_x | m_y | m_{x+y} | Contribution of m_y to m_{x+y} |
|-------|-------|-----------|------------------------------------|
| 1 | 1 | 1.414 | .414 |
| 3 | 1 | 3.162 | .162 |
| 5 | 1 | 5.099 | .099 |
| 10 | 1 | 10.050 | .050 |
| 100 | 1 | 100.005 | .005 |

15.10. Variations of muzzle velocity at ballistic firings

The variations in muzzle velocity may be divided into two main classes—random and systematic.

The random variations in a series using one lot of ammunition are caused by combinations of variations in such things as the ignition system, the propellant charge, the projectile and the velocity measuring apparatus. These variations are fully discussed in Sections 12.04, 12.09, and 14.03.

The contributions of most of these variations to mean deviation in muzzle velocity are extremely difficult to separate and the effects of only a very few are known.

Systematic variations which contribute to inaccuracy but not to mean deviation in muzzle velocity are variations according to occasion, lot and gun. Some of the occasion variations can be isolated, such as the effect of temperature on any one occasion, while lot, gun, and wear variations are generally known to a fair degree of accuracy.

The average mean deviation in muzzle velocity for a five-round series is normally about 0.2 per cent. of the muzzle velocity in medium-size guns. The figure is larger in small guns, being about 0.45 per cent. of the muzzle velocity in guns of 40 mm. calibre, and for low charges in howitzers where the mean deviation may be as much as 1 per cent. of the muzzle velocity. With these exceptions it rarely falls outside the range 0.1 per cent. to 0.3 per cent. of muzzle velocity.

It has not up to now been possible to isolate the sources of irregularity sufficiently to build up any particular observed mean deviation.

The following table shows typical contributions to irregularity in measured muzzle velocity at cordite proof which have up to now been discovered. The figures are discussed in detail below.

| Source of variation | Permitted variation per cent. | Muzzle-velocity equivalent per cent. | Corresponding mean deviation per cent. of M.V. |
|----------------------------|-------------------------------|--------------------------------------|--|
| Velocity measurement | ± 0.1 | ± 0.1 | 0.03 |
| Weight of proof shot | ± 0.2 | ∓ 0.08 | 0.03 |
| Charge weight | ± 0.02 | ± 0.012 | 0.004 |
| Effective chamber capacity | ± 0.6 | ∓ 0.15 | 0.05 |
| Propellant web size | ± 1.0 | ∓ 0.15 | 0.05 |
| Total | — | — | 0.08 |

If the observed mean deviation is 0.2 per cent. of the muzzle velocity there are further components whose resultant mean deviation is

$$\sqrt{(0.2^2 - 0.08^2)} = 0.18 \text{ per cent.}$$

In other words all the sources of variation in the above table are practically negligible. The figures are of course typical figures and there may be quite wide divergences from these figures in any specific instance. They will be discussed more fully in the following paragraphs.

VARIATIONS IN MUZZLE VELOCITY MEASUREMENTS

The variations in muzzle velocity measurement may be divided into three main types : systematic variations affecting the level of muzzle velocity, those affecting the consistency, and random variations.

Variations of the first type are only discovered when there is an independent check. On rare occasions they have been very large, but more often than not they are reasonably constant for any one proof range.

Variations of the other two types cannot normally be separated. A recent trial indicated however that the total mean deviation in muzzle velocity measurement (by Boulengé) due to both types was about 0.3 per cent. of the muzzle velocity for low velocity charges and about 0.1 per cent. for high velocity charges.

The same trial showed that more modern types of equipment under favourable conditions could be several times as accurate.

TOLERANCE IN PROOF SHOT WEIGHT

Until recently the tolerances were even narrower, being as small as 0.025 per cent. for calibres above 9.2 inches, with an upper limit of 0.08 per cent. for calibres under 6 inches. It is clear from the table above that such accurate weights are not necessary, and indeed it was for this reason that the tolerances were widened.

VARIATIONS IN EFFECTIVE CHAMBER CAPACITY

For B.L. guns the effective chamber capacity depends on the length of ram and on the volume of the projectile behind the driving band. In Q.F. guns it also depends on the volume of the metal of the cartridge case—that is to say, on its weight. The volume of proof shot behind the band has a permissible variation in general of about 0.3 per cent. of the chamber capacity, but in some cases it may be considerably greater (e.g. in the Q.F. 25-pr. where it equals 1.34 per cent.). These figures are equivalent to mean deviations in muzzle velocity of 0.02 per cent. and 0.08 per cent. respectively. Variations in cartridge case weight have a mean deviation of about 0.2 per cent. corresponding to a mean deviation in muzzle velocity of 0.05 per cent.

VARIATIONS IN PROPELLANT WEB SIZE

The variation of web size from stick to stick has a mean deviation of about 0.6 per cent. for SC cord and of about 2.5 per cent. for other propellants and shapes. The mean deviation for n sticks of WM will therefore be $2.5/\sqrt{n}$ per cent., and if $n = 100$ the mean deviation = 0.25 per cent. in size corresponding to about 0.04 per cent. in muzzle velocity. The number of sticks per Service charge varies considerably, and with SC the contribution to mean deviation in muzzle velocity due to this source is unlikely to exceed 0.004 per cent. At the other end of the scale WMT charges in small guns have only a few sticks and the contribution to mean deviation in muzzle velocity is about 0.08 per cent. Size is therefore never an important factor within a lot of propellant.

OTHER SOURCES OF VARIATION

Other factors such as variations in ignition, in the force and rate of burning of the propellant, and in the driving band, have so far eluded isolation or measurement.

15.11. The combination of variations at cordite proof

The principal series-to-series variations which arise at cordite proof for any given combination of gun and ammunition are those between occasions, between guns and between lots, whose population standard deviations are denoted respectively by σ_D , σ_G and σ_L . Minor contributions to the series-to-series variations are those due to the residual variance and to gun \times occasion and lot \times occasion interactions. The standard deviations of these variations are denoted by σ_0 , σ_{GD} and σ_{LD} respectively. The lot \times occasion interaction is also called the "Hymans effect"* (see Section 14.04).

* J. C. S. Hymans. *A statistical investigation into an error arising in the assessment of corrected velocities at cordite proof.* R.D./P. & E.E. Report 4/43.

These quantities may be estimated from the normal data of cordite proof from the formulae given below. These all refer to n -round series at proof.

THE VARIATION OF THE STANDARD ABOUT THE WEAR LINE

The variance about the muzzle velocity/E.F.C.-value curve for a gun firing a single lot is an estimate of

$$\sigma_D^2 + \sigma_{LD}^2 + \sigma_{GD}^2 + \sigma_0^2/n$$

THE VARIATION AT MASTER STANDARDISATION OR AT GUN PROOF

The variance between the mean muzzle velocities of a number of guns each firing on a different occasion the same lot of propellant is denoted by V_G and is an estimate of

$$\sigma_G^2 + \sigma_{GD}^2 + \sigma_{LD}^2 + \sigma_D^2 + \sigma_0^2/n$$

THE VARIATION AT CURRENT STANDARDISATION OR AT REPROOF

The variance between the corrected muzzle velocities of a lot fired against a standard on several occasions is an estimate of

$$2\sigma_{LD}^2 + \sigma_0^2/n + \sigma_0^2/(n - 1)$$

where n standard rounds and $n - 1$ rounds of the lot are fired. This is denoted by V_p .

From these estimates and from analysis of variance of cordite proof firings it is possible to estimate the various constituent standard deviations, but difficulty arises in the separation of σ_G and σ_{GD} since the only evidence of the gun-occasion interaction arises out of special trials involving the firing of a number of guns on different occasions.

15.12. Errors arising out of adjustment of charges

The normal procedure of charge adjustment is described in Chapter XIV. From comparison with the above paragraphs it is clear that errors must be introduced. The sizes of the errors as measured by the variance are as follows :—

LOTS PROVED AGAINST THE SAME CURRENT STANDARD

The lot-to-lot variance of the error of estimate is simply V_p .

LOTS PROVED AGAINST DIFFERENT CURRENT STANDARDS DERIVED FROM THE SAME MASTER STANDARD

An additional source of variation is introduced with a variance of $V_p/5$ in the case of a current standardisation consisting of 5 comparative firings.

The lot-to-lot variance of the error of estimate is therefore $6V_p/5$.

LOTS PROVED AGAINST CURRENT STANDARDS DERIVED FROM A SERIES OF MASTER STANDARDS

The variance of master standardisation further inflates the variance already calculated. Since master standardisation is normally fired in a separate gun on each of six occasions this variance is $V_G/6$.

The lot-to-lot variance of the error of estimate is now

$$6 V_p/5 + V_G/6$$

15.13. Applications to routine problems ; theory

METHODS OF REDUCING PROOF

In the description of control chart technique it was shown that the internal variation of the samples could be used to deduce regions within which the variability of a product could be kept under certain degrees of control.

In 1942 it was proposed that this conception of regions be extended to the adjustment of charge weights.

The innermost region $\bar{C} \pm 2 K \sqrt{[V_0/n + V_0/(n-1)]}$ (where \bar{C} denotes the mean adjusted charge weight of a large number of lots and K is the factor transforming muzzle velocity into charge weight) was called the *Standard charge zone* and it was recommended that all lots whose adjusted charge weights fell inside this zone should be filled to a fixed charge weight i.e. the mean of the zone.

The larger region $\bar{C} \pm 3 K \sqrt{[V_0/n + V_0/(n-1)]}$ was called the *Fixed charge zone*. It was suggested that if all adjusted charge weights fell inside this zone, proof would be unnecessary and all lots should be filled to the same charge weight.

These suggestions, originally based on an analogy with industrial applications of control charts, were subsequently found to be reasonable, if somewhat restrictive.

The variance of the error of adjustment of lots proved against the same current standard is V_p while the real lot-to-lot variance may be written as V_L where both these variances are in terms of velocity. V_L can be found from the relationship,

$$\text{Variance of adjusted charge weights} = K^2 (V_p + V_L).$$

If then V_p is greater than V_L adjustment of lots will cause increased dispersion. If V_p is equal to V_L , nothing is gained by adjustment, while if V_p is less than V_L adjustment of charges will always decrease dispersion. However, if V_p is not very much less than V_L , very little accuracy will be lost by having some suitably chosen criterion for adjustment similar to that of the standard charge zone. The limits need not, however, be $2 K \sqrt{[V_0/n + V_0/(n-1)]}$ and will depend on the relative sizes of V_p and V_L .*

CONTROL CHARTS

This sub-section is confined to a consideration of charts for the purpose of controlling quality. In the main, two types of chart are important and they are discussed below.

Separate control charts are kept for each gun-ammunition combination and propellant factory and points corresponding to the adjusted charge weights and mean deviations of the lots under proof are plotted in order of proof. When the points as charted show distinct trends or tendencies to cluster near a limit, further research is necessary. There are other sources of evidence, such as the chart of the standard ballistics described below, and various check firings and reproofs against other standards. When evidence points to either a change in the standard ballistics or a trend in manufacture, suitable action is taken (see Section 14.09).

Collateral information can be obtained from a control chart of standard ballistics. The ballistics of the standard are subject to occasion-to-occasion variation about the muzzle velocity/E.F.C.-value curve. Given the occasion-to-occasion variation, and the average muzzle velocity/E.F.C.-value relation for the gun, a control chart (i.e. a wear curve with action limits) can be constructed. When a point lies outside the control regions there is an indication that some abnormal condition did not apply equally to the lots at proof. This is checked against the control charts of adjusted charge weights and mean deviation. If the adjusted charge weights are quite normal, it may mean that the offending point is due to some abnormal *day* condition. If, on the other hand, the adjusted charge weights lie well away from the normal run there is a clear indication that the standard has misbehaved. In both cases further investigations are made to see if further information can be extracted.

* E. S. Pearson and N. L. Johnson, *Notes on the problem of adjustment of lot values, as a result of proof firings.* (Departmental note : S.A.B., Ordnance Board 1942).

SPECIFICATIONS

The important figures derived from cordite proof are the adjusted charge weight, which for ease of filling and safety in the gun should not exceed certain limits, the mean deviation in muzzle velocity, and the maximum pressure at the adjusted charge weight.

The accumulated data from control charts gives a great deal of information on the first two, while if the maximum pressure is exceeded and this is confirmed by reproof, the lot is rejected out of hand. If the adjusted charge weight is too high the lot may either be reworked or blended with a faster lot, and subsequently proved again.

The mean deviation in muzzle velocity as laid down in the specification has generally been arbitrarily fixed, and need not bear any relation either to the level of regularity actually achieved, or to that required for the gun to fulfil its role efficiently. Strictly speaking, it should be possible to tell, from a consideration of internal and external ballistic errors, how far the internal errors can be inflated without materially affecting the external errors. (These two interact on each other in the same way as the two independent mean deviations illustrated in Section 15.10). From the cordite-proof control charts it can be seen whether or not this maximum acceptable internal ballistic variation is related to the quality of production. If it is, the specification should be brought into line (if necessary). If the cordite-proof mean deviation is much too large for the user, ways and means of improving the regularity should be considered, and if none is acceptable the specification should be brought into line with production. Finally, if the mean deviation at cordite proof is much lower than necessary, it becomes a matter of policy whether more latitude should be allowed to the manufacturer, or whether he should be forced to produce a product which is unnecessarily uniform and perhaps more costly.

15.14. Difficulties arising in practice

HETEROGENEITY

A very extensive statistical investigation of sources of inaccuracy in firings of guns at proof ranges produced some interesting but rather confusing results. The residual variance, which had originally been suggested to be constant for a particular combination of gun and ammunition was found instead to vary quite widely.

In particular the level of the residual variance varied considerably from lot to lot, while individual guns firing the same standard lot at cordite proof gave significantly different values for the residual variance.

Gun-to-gun variations in gradients of muzzle velocity/E.F.C.-value curves were also found to be significantly different and to be much wider than had been thought.

In the report these variations were described as being evidence of *heterogeneity*. Where heterogeneity exists, the normal statistical methods may not always apply.

CONTROL OF QUALITY OF MANUFACTURE

In propellant manufacture, once the propellant has come from the presses it goes to drying houses to mature. This maturing process may take several weeks. Only then is a sample selected for proof. The delay between manufacture and proof may be even longer, for sometimes lots are manufactured in anticipation of a demand and stored until they are required. They may be stored for many months before they are filled, and it is normal to postpone the proof of such lots until filling is fairly imminent. It therefore becomes impossible to use the control charts as action limits for the manufacturer to make some alteration in manufacture and the charts tend to be used as records and for information only as far as the manufacturer is concerned.

15.15. Application to routine problems ; practice

GENERAL

Statistical methods are being applied increasingly to the solution of the various problems outlined in this chapter. One field in which they have helped greatly has been in the alteration of tolerances, for example of proof shot, where the limits imposed on the manufacturer were unnecessarily close.

METHODS OF REDUCED PROOF

Proof has been reduced in a variety of ways, but few have been the result solely of statistical analysis.

Fixed charge weights are filled in special charges such as star shell where consistency of muzzle velocity is of little importance, while the lowest charges in multiple charge weapons (e.g. howitzers) are now filled to fixed charge weights as a result of statistical considerations based on control charts.

In the later part of the war, proof of SC cordite for the Naval Service was of a different character from normal proof. Every lot was fired as a ballistic series at gun proof, and every fourth lot was given a normal proof in addition. Provided that these results fell within certain limits, all filling was to a fixed charge weight which was altered from time to time as the proof results showed it to be necessary.

CONTROL CHARTS

The difficulties of applying the full technique of control charts in practice were mentioned in Section 15.14. The value of the charts was, however, demonstrated when the control charts of the Land Service Inspection Department were compared with those kept at the proof ranges. The former were plotted in order of manufacture and were thus different from the latter, on which the points were plotted in order of proof. The comparison of the two sets of control charts revealed a substantial amount of information unobtainable from either set of charts alone, and they, in conjunction with the charts of standard ballistics, and the results of check firings and reproofs form a coherent history of propellant production and proof which repays intensive study.

SPECIFICATIONS

Some research has been done into the application of statistical methods for the amendment of existing cordite proof specifications and the formulation of specifications for new charges, on the lines suggested in Section 15.13. There are considerable technical difficulties which together with evidence of heterogeneity have retarded progress in this direction.

CHAPTER XVI

MODERN EXPERIMENTAL INTERNAL BALLISTICS

16.01. The three aspects of internal ballistics in which the greatest uncertainty prevails are :—

- (i) The manner and rate of burning of the propellant,
- (ii) The pressure gradient in the propellant gas, and
- (iii) The resistance to the forward motion of the projectile.

As regards the burning of the propellant, considerable experimental work has been done in closed and vented vessels (Chapters V and XIII), but it is by no means safe to assume that the laws derived in experiments at constant volume are equally valid under the different conditions prevailing in a gun, where the movement of the projectile may cause a stream of gas to flow over the burning surface of the propellant, and will bring about an expansion-cooling of the gas, both of which factors may alter the manner in which the propellant burns.

The pressure gradient in the propellant gas has been dealt with in Chapter VII, but approximations and assumptions are involved in the treatment. Further, as modern requirements call for greatly increased muzzle velocities and thus increased values of the ratio of weights of charge to projectile, on which ratio the pressure gradient depends, the importance of a more exact knowledge of this pressure gradient is evident.

The resistance to the forward motion of the projectile enters into most methods of internal ballistic calculations ; but the only commonly-applied method of estimating the magnitude of this resistance has been from the analysis of measurements of maximum pressure and muzzle velocity : in fact the value assigned to the resistance has been little more than an empirical correction necessary to reconcile a rather inadequate theory with practically achieved results.

Considerations such as these have prompted experimental work in several countries ; in these experiments measurements were made of various quantities inside the gun during the passage of the projectile up the bore. These experiments were naturally difficult and elaborate, and could not be repeated for a large range of equipments, but the results obtained therefrom are nevertheless valuable. Some of these experiments will be described in the following sections.

16.02. Experiments in the United Kingdom

Experiments in the United Kingdom were carried out by the Armament Research Establishment at Woolwich and were reported in 1944.* In these experiments a modified BL. 6-inch Mark XXII gun was used, in the barrel of which 19 radial holes were drilled for gauges ; these holes were so spaced that the projectile passed them at approximately equally-spaced time intervals. Series were fired with the Service charge and also with a charge of the same propellant of larger size and increased in weight by some 40 per cent. Pressures were recorded by tourmaline piezo-electro gauges and the recording apparatus was such that pressure-time curves could be recorded simultaneously from two gauges. The recording unit contained the necessary synchronising and switching gear, and an element which marked on the same time-scale the closing of a number of external circuits. Some of the gauge holes in the barrel were occupied by space-time gauges by means of which the projectile caused a succession of short-circuits during its passage down the bore. At the firing of any given round, pressures were measured by a piezo-electric gauge mounted on the front face of the vent-axial

* J. B. Goode and N. Lockett. *The space and time variation of pressure in the bore of a gun.* AC. 6953, ARD. Ballistics Report 31/44.

and by a second at one of the gauge holes in the bore, space gauges being inserted in the remaining gauge holes. By recording a number of similar rounds and varying the position of the pressure gauge in the barrel, a complete picture of the pressure-space-time relation was built up.

The analysis of the experimental results led to the following conclusions :—

- (i) The ratio of the gas pressure on the base of the projectile to that at the rear end of the chamber could be represented with reasonable accuracy by the expression

$$1 - Cz/2w$$

- (ii) The resistance to the forward motion of the projectile after the first eight inches of shot travel was approximately constant and equivalent to a gas pressure of about 0.9 tons per sq. in. During the first eight inches of shot travel, in this gun (which was rather more than half worn) and while the driving band was passing through the eroded portion of the bore, the resistance rose to the steady value ; there was no evidence of a definite shot-start resistance, but on two rounds the resistance was slightly higher than the steady value from about four to eight inches shot travel.
- (iii) The burning of the charge conformed well with that found in closed-vessel experiments ; the agreement was slightly better if the value of the pressure used in the burning equation was that at the rear end of the chamber than if an allowance were made for the pressure gradient.

16.03. Experiments in Germany

In Germany a certain number of scattered experiments were undertaken before and during the second world war, but the only systematic experimental attack on the problems of internal ballistics was that carried out under the direction of Rossmann by the firm of Krupp at their Experimental Establishment at Meppen from 1935 onwards ; they were reported to the German Air Research Academy.*

Rossmann carried out his experiments in an 8.8-cm. Anti-Aircraft gun. He used three different systems for collecting data ; of these, two were used simultaneously with each round fired.

With every round fired the gas pressure at the rear end of the chamber was measured by a quartz piezo-electric gauge mounted in the base of the cartridge case.

To determine the travel of the shot in terms of time he used special projectiles bored axially ; a ring at the front of the projectile made electrical contact with a *contact-bar* which was secured to the centre of the cartridge case but insulated from it. The bar passed up the centre of the bore and its surface was interrupted by a series of narrow insulating segments, so spaced that the projectile would take about 0.2 milliseconds to pass from one to the next. The records were reproducible for about 350 mm. (i.e. for about the first tenth of the shot travel).

Other quantities were measured by means of piezo-electric gauges mounted in the projectile the front of which was recessed conically, forming a *collecting funnel*. The lead from the gauge passed from the centre of the funnel forward axially along the bore to a post some distance in front of the muzzle, and thence to an amplifier and oscillograph. Tests without gauges in the projectile showed that spurious voltages, variously ascribed, were picked up by the amplifier shortly before the projectile reached the muzzle ; these were unimportant when the quantities being measured were large, but when they were small these voltages spoiled the

* T. Rossmann. *New researches in internal ballistics*. Jahrbuch der Deutschen Akademie der Luftfahrtforschung, 1940/41. English translation by N. Lockett, ARD., Ballistic Branch Translation 2/45.

records after about one-third of the total shot travel. The quantities which were measured by piezo-electric gauges were :—

- (i) *The resistance to shot travel.* For this purpose a piston of area a slid freely in an axial hole open to the base of the projectile ; this piston was rigidly attached to an inertia weight which bore on one face of the piezo-electric gauge of which the other face was rigidly supported in the body of the projectile. If m is the joint mass of the piston and inertia weight, A the total area of the base of the projectile which is exposed to the pressure of the propellant gas, and M the total mass of the projectile, it can be shown that if a and m are such that $a/A = m/M$, the reaction which is recorded by the gauge is proportional to the resistance to the forward motion of the projectile, and is independent of both the gas pressure and the acceleration of the projectile.
- (ii) *Gas pressure at the base of the projectile.* The gas pressure acted on an axial piston which bore against a piezo-electric gauge mounted in the body of the projectile. An inertia weight, of mass equal to that of the piston, set back against a second gauge of equal sensitivity, also mounted in the projectile, and connected in series with the first. The force recorded by the two gauges together was thus solely due to the gas pressure on the piston.
- (iii) *Acceleration of the projectile.* An inertia weight set back against a piezo-electric gauge mounted rigidly in the body of the projectile.

The following checks were applied :—

- (i) The pressure curve at the base of the cartridge case, as recorded by the gauge, was substantially the same as that recorded simultaneously in an equivalent position with a manganin resistance gauge.
- (ii) The mean velocities between contacts on the contact-bar were plotted against times to form a stepped velocity-time curve ; these curves were practically identical from 40 to 300 mm. shot travel.
- (iii) The difference between the force due to the measured gas pressure on the base of the projectile and the measured force of resistance was plotted against time on the same graph as the plot of the measured mass-acceleration of the projectile ; the agreement was good qualitatively and quantitatively.
- (iv) The acceleration-time curve was integrated to give a velocity-time curve and plotted on the same graph as the stepped velocity-time curve obtained from the contact bar ; it was found to pass almost exactly through the corners of that curve.
- (v) The stepped velocity-time curve was differentiated numerically and subtracted from the measured gas-pressure curve to give a stepped resistance-space curve ; this agreed reasonably well with the resistance curve directly recorded.

The following conclusions were arrived at :—

- (i) The burning of the propellant in the gun followed the same law as in the closed vessel.
- (ii) The pressure-gradient between the rear face of the chamber and the base of the shot, *for the particular conditions of the trial*, was consistent with the hypothesis that half the mass of the propellant moved as a rigid body with the projectile.
- (iii) The gas pressure at the base of the projectile and the resistance to motion rose together from zero for about 3 milliseconds to a value of about 1 ton/sq. in. before the projectile started to move ; with a weakly rammed shot, the coincidence only lasted for 2 milliseconds, and the resistance at this point was only about $\frac{1}{4}$ ton/sq. in. After the projectile started to move the resistance rose to two further peaks, of about 2 and $2\frac{1}{2}$ tons/sq. in., at 4 and $4\frac{1}{2}$ milliseconds respectively ; the projectiles had two driving bands, and the two peaks in the resistance curve corresponded

closely with the positions at which the two driving bands in turn entered the steeper part of the forcing cone. After the engraving of the driving bands was completed, the resistance to forward motion fell off steadily to about $\frac{1}{4}$ ton/sq. in., at a travel of 350 mm., the furthest point at which it was measured.

16.04. Experiments in the United States

The most elaborate and extensive series of experiments of this type were carried out on behalf of the United States War and Naval Departments under a contract placed by the National Defence Research Committee. The trials were fired in the David W. Taylor Model Basin of the Bureau of Ships, U.S. Navy, under the direction of H. L. Curtis of the National Bureau of Standards. The staff was provided by the National Bureau of Standards, the Geophysical Laboratory of the Carnegie Institution at Washington and, for certain measuring instruments, by the Leeds and Northrup Co.*

In this series of experiments the quantities measured included the following :—

The displacement-time curve of the travel of the projectile relative to the gun.

The velocity and retardation of the projectile outside the muzzle.

The pressure of the propellant gas in the chamber and at a series of holes bored in the barrel of the gun.

The pressure in the recoil cylinder.

The displacement, velocity and acceleration of the recoiling gun.

The circumferential and axial stresses in the gun barrel.

The amount of heat transferred to the gun barrel.

Records were taken on a battery of 10 cathode ray oscillographs which were grouped in five pairs, each pair (except in the case of the measurement of gas temperature) being recorded on a revolving drum camera. Time marks at 1,000 cycles per second from a common source were imposed on the trace from each oscillograph and two *common times* (one from the first movement of the firing pin and a second from a rupteur at 50-ft. from the muzzle) were also imposed on all traces. In addition, a voltage calibration was recorded through the oscillograph on the drum cameras at the time of firing. The oscillograph equipment included the necessary amplifiers and also switching gear for controlling the sequence of camera shutter, oscillograph control, firing and calibration.

For the earlier rounds the displacement-time records were obtained by means of circumferential strain gauges or by contact pins screwed through the barrel wall, but for all the later rounds use was made of the micro-wave interferometer technique. By this technique a micro-wave transmitter and a receiver were mounted facing each other on opposite sides of the gun muzzle ; a portion of the radiation, if of the appropriate wave length, travelled down the barrel, which acted as a wave guide, was reflected from the nose of the projectile and interfered with the direct radiation ; the resulting peaks and troughs in the received radiation gave a measure of the position of the projectile in the bore. The records obtained were precise and smooth but ceased a few calibres short of the muzzle.

Piezo-electric gauges for the measurement of gas pressure were employed in the early stages but were subsequently dropped in favour of resistance gauges ; these consisted of steel cylinders, closed at one end, with the open end exposed to the gas pressure. The expansion of the cylinder under pressure caused a change in the resistance of a helix of "advance" wire wound round the gauge cylinder.

In order to measure the temperature of the propellant gases, quartz windows were fitted to the holes bored in the chamber and barrel ; the radiation from these windows passed through

* *Report on firing of first eleven rounds in 3-inch gun at David W. Taylor Model Basin during May, June and July, 1943.* NDRC Report A. 229, OSRD Report No. 2019. *Second report on firing of 3-inch gun in David W. Taylor Model Basin, October 1943 to May 1944.* NDRC Report A. 323, OSRD Report No. 4986.

a red and blue filter respectively onto two photo-cells and the oscillograph recorded the ratio of the intensity of the radiation received by the two cells. This ratio gives a measure of the gas temperature.

The displacement of the recoiling parts was measured by means of a slider rigidly attached to the gun barrel which moved over either a bar with insulated interruptions or over a potentiometer slide-wire.

Recoil velocity was measured directly by the movement of a conductor attached to the gun barrel in a uniform magnetic field. Two forms of recoil velocimeters were used ; in the first the conductor was in the form of an armature which was rotated by the movement of the gun ; in the second, the conductor moved in an annular space in which the magnetic field was uniform and radial. The acceleration of recoil was found either by the electric differentiation of the velocity voltage or by a piezo-electric accelerometer.

The heat transfer to the gun barrel was measured by means of thermo-couples, of which four were attached to the outer surface of the barrel and two were embedded in holes that were bored to within a quarter of an inch of the bore surface.

The trials were fired in a Q.F. 3-inch gun with a nearly new barrel liner with increasing twist of rifling ; the weight of the projectile was constant throughout and propellants of two different compositions were used. With both propellants the full service charge had a loading density of about 0.5 and gave a muzzle velocity of 2,700 feet per second at a true maximum pressure of $18\frac{1}{2}$ tons/sq. in. With one propellant, series were fired with charge weights of 100, 90, 80, 70, 60 and 50 per cent. of the service charge and with the other propellant at 100, 75 and 50 per cent. Another variable introduced was that with some rounds the bore was dry and with other rounds it was greased as in service.

The following were amongst the conclusions reached from an analysis of the results :—

- (i) The motion of the propellant either in solid or gaseous form was such that the centre of gravity of the propellant moved with an acceleration which was, with full charge 49 per cent., and with half charge 40 per cent. of that of the projectile ; the amount by which this percentage was less than 50 per cent. was an indication of the extent to which the density of the propellant and propellant gases was higher towards the breech than it was at the base of the projectile.
- (ii) The maximum pressure with the dry bore was greater by about 10 per cent. than that with the greased bore with all charges. There was some indication that this percentage was higher at reduced charges than with full charge. The muzzle velocity was about 20 f.s. higher with full charge, and 100 f.s. with reduced charge with dry bores in comparison with greased bores.
- (iii) The maximum pressure indicated by electric gauges was about 15 per cent. higher than that given by copper crusher gauges with all charges.
- (iv) The pyrometers indicated a first flash of radiation from the black powder of the primer followed by a temperature minimum : the temperature then rose to a maximum which was of the same order as the adiabatic flame temperature of the propellant and subsequently fell by some 600° C. as the projectile approached the muzzle. The temperature gradient down the bore was somewhat greater than was expected from normal internal-ballistic theory. It was believed that the sample of gas of which the pyrometers measured the temperature was of a considerably greater depth than that of which the temperature would be expected to be reduced by bore-surface effects, but probably did not extend far beyond the hole in which the quartz windows were mounted. All temperature measurements showed violent fluctuations which were not symmetrical on the two sides of the barrel.

- (v) The temperature and pressure gradients in the barrel were consistent with a rate of heat transfer to the barrel walls which increased towards the muzzle as the velocity of the projectile and therefore of the gas stream increased and also with a very considerably increased heat transfer at the necking of the cartridge case.
- (vi) The resistance to the forward motion of the projectile was deduced by comparing the acceleration of the projectile obtained from the micro-wave interferometer records with the pressure on the base of the shot derived from extrapolation of the pressure gradient curves. This resistance was found to vary widely from round to round under apparently identical conditions. In a typical round in a dry bore the resistance rose during band engraving to a maximum of about 2.7 tons/sq. in. (equivalent bore pressure) and then fell at about 2 inches shot travel to a minimum of $\frac{1}{4}$ ton/sq. in., thereafter it rose sharply to a maximum of about $1\frac{3}{4}$ tons/sq. in. at a shot travel of about 2 ft. and subsequently fell fairly steadily to almost zero at the muzzle. The engraving resistance rose to about double the value with dry bores in comparison with greased bores.
- (vii) The burning of the propellant was not inconsistent with that observed in closed vessel determinations.
- (viii) The radial driving band pressure in the early part of the shot travel was about 30 tons/sq. in. with both greased and dry bores for all charges. As the projectile advanced, the band pressure with greased bores remained approximately the same but with dry bores it decreased very considerably with full charges but to a much less extent with the 50 per cent. charge.
- (ix) Attempts were made to determine the velocity of the projectile at the moment that the driving band left the muzzle ; the velocity forward of the muzzle was extrapolated backwards to the instant of shot ejection and the velocity in the bore extrapolated forward by several methods from measurements of shot travel against time ; the latter gave results which varied quite widely according to the method of extrapolation which was used. It was claimed, however, that it was possible to detect the amount by which the projectile was accelerated by the muzzle blast after it had left the gun, though estimates of this amount varied from 2 to 20 f.s.
- (x) The start of recoil of the gun occurred earlier by a measurable amount than the start of forward motion of the projectile ; this was due to the forward motion of the propellant under the action of the burning of the primer.

SUMMARY OF NOTATION

The following general notation is used in all Chapters except Chapters III and XV :—

- A** Cross-sectional area of the parallel portion of the bore including the area of the grooves when the bore is rifled. In the absence of a precise value it may be taken as $\frac{1}{4} \pi d^2 \times 1.02$.
- C** Weight of propellant charge.
- D** Propellant size ; the smallest linear dimension of a piece of the unburnt propellant.
- E** Thermodynamic efficiency of the gun.
In Chapter II, the internal energy of the propellant gases.
- F** Force constant of the propellant.
- J** Mechanical equivalent of heat.
- K₀** Cubic capacity of the chamber when the breech is closed and the shot is in its rammed position. With fixed ammunition, the cubic capacity of the cartridge case when the shot is assembled in the case (except in Chapter II).
- K₃** Total cubic capacity of the bore, which comprises the chamber and the parallel portion.
- R** Gas constant.
- T** Absolute temperature of propellant gases at time t .
- V** Specific volume of propellant gases (except in Chapter VII).
- b*** Co-volume of propellant gases.
- d*** Calibre, i.e., the diameter of the parallel part of the bore across the lands.
- f*** Fraction of D remaining unburnt at time t .
- l*** Equivalent length of initial air-space in chamber = $(K_0 - C/\delta)/A$.
- p*** Mean pressure of the propellant gases at time t (except Chapter VII).
- t*** Time.
- v*** Velocity of shot.
- w*** Mass of shot.
- w₁*** Equivalent mass moved (see Chapter VII) = $1.05 w + \frac{1}{3}C$.
- x*** Shot travel at time t , i.e., the distance the shot has moved from its initial position.
- x₃*** Shot travel to muzzle = $(K_3 - K_0)/A$.
- z*** Fraction of mass of charge burnt at time t .
- α** Pressure index in rate-of-burning law.
- β** Rate-of-burning coefficient.
- γ** Ratio of specific heats of propellant gases.
- δ** Density of solid propellant.
- θ** Form coefficient of propellant.
- Δ** Loading density = C/K_0 in metric units ; $27\ 68C/K_0$ when C is in lb. and K_0 in c. in.

Generally, suffix ₀ indicates initial values ; suffix ₁, values when the pressure is maximum (except w_1) ; suffix ₂, values at all-burnt ; suffix ₃, values as the shot passes the muzzle.

TABLES

- 1.01 Composition and physical properties of propellants.
- 2.01 Atomic composition and heats of formation of propellant constituents.
- 2.02 Heats of formation of the products of explosion.
- 2.03 Atomic composition and heats of formation of propellants.
- 2.04 Equilibrium constants.
- 2.05 Mean molecular heats.
- 2.06 Equation-of-state coefficients B and C.
- 2.07 Equilibrium-constant coefficients ΔB and $\frac{1}{2}\Delta C$.
- 2.08 Internal-energy coefficients E_1 and E_2 .
- 2.09 Additive constants of propellant constituents.
- 2.10 Propellant constants.
- 3.01 Functions for the solution of the flame equation.
- 5.01 Rate-of-burning indices and coefficients.
- 8.01 to 8.07 Functions for the Hunt-Hinds solution.
- 8.08 Propellant data in British units for linear-law calculations.
- 8.09 Ounces and drams as decimals of a pound.
- 10.01 Ballistic functions for NCT.
- 15.01 Significance test t .
- 15.02 Variance ratios.

TABLE 1.01
Composition and Physical Properties of Propellants

(The thermal data in this table are always subject to revision)

| Nomenclature | Percentage Composition | | | | | | | | Density at 20° C. gm/c.c. | Gas volume c.c./gm. | Calorific value (water liquid) cal./gm. |
|--------------|------------------------|-----------------------------|-----------|---------------|---------------|---------|----------------|------------------|---------------------------|---------------------|---|
| | Nitroglycerine | Nitro-cellulose (N Content) | Carbamite | Mineral Jelly | Diphenylamine | Picrite | Dinitrotoluene | Dibutylphthalate | | | |
| MD | 30 | 65 (13·1) | | 5 | | | | | 1·58 | 940 | 1025 |
| W | 29 | 65 (13·1) | 6 | | | | | | 1·60 | 910 | 1025 |
| WM | 29·5 | 65 (13·1) | 2 | 3·5 | | | | | 1·59 | 934 | 1013 |
| SC | 41·5 | 49·5 (12·2) | 9 | | | | | | 1·57 | 957 | 970 |
| HSC | 47 | 49·5 (12·2) | 3·5 | | | | | | 1·61 | 866 | 1175 |
| A | 25·5 | 56·5 (13·1) | 4·5 | 3·5 | | | 10 | | 1·54 | 1026 | 810 |
| AN | 25·5 | 56·5 (13·1) | 4·5 | 3·5 | | | 10* | | 1·54 | 1018 | 825 |
| ASN | 36·25 | 50 (12·2) | 5·75 | | | | | 8† | 1·57 | 1021 | 785 |
| N | 18·7 | 19 (13·1) | 7·3 | | | | | 55‡ | 1·66 | 1058 | 765 |
| NQ | 20·6 | 20·8 (13·1) | 3·6 | | | | | 55‡ | 1·68 | 1001 | 880 |
| NFQ | 21 | 16·5 (12·2) | 7·5 | | | | | 55‡ | 1·64 | 1066 | 755 |
| NCT | | 99·5 (13·0) | | | 0·5 | | | | 1·62 | 893 | 780 |
| NH§ | | 86 (13·15) | | | 1 | | 10 | 3 | 1·57 | 978 | 765 |
| FNH/P§ | | 83 (13·15) | | | 1 | | 10 | 5** | 1·57 | 1005 | 740 |

* With 0·7 per cent. potassium nitrate

† With 4·5 per cent. potassium cryolite

‡ With 0·3 per cent. sodium cryolite

** With 1, 2 or 3 per cent. potassium sulphate

§ Dupont manufacture.

TABLE 2.01

**Atomic Composition and Heats of Formation of Propellant Constituents
At Constant volume at 300° K**

(See Sections 2.02, 2.03. The thermal data in this table are always subject to revision).

| Constituent | Mol Wt. | Atomic Composition in gm. atoms/gm. | | | | Heat of combustion. cal/gm. | H.F. of Products. cal/gm. | H.F. of Substance. cal/gm. |
|---|---------|-------------------------------------|---------|---------|---------|-----------------------------|---------------------------|----------------------------|
| | | C | H | N | O | | | |
| Nitrocellulose 11.5% N | | 0.02333 | 0.03068 | 0.00821 | 0.03586 | 2536 | 3228 | 692 |
| 12.0 | | 0.02274 | 0.02933 | 0.00857 | 0.03608 | 2471 | 3127 | 656 |
| 12.2 | | 0.02250 | 0.02879 | 0.00871 | 0.03617 | 2445 | 3086 | 641 |
| 12.4 | | 0.02226 | 0.02826 | 0.00885 | 0.03626 | 2419 | 3046 | 627 |
| 12.6 | | 0.02203 | 0.02772 | 0.00899 | 0.03635 | 2393 | 3005 | 612 |
| 12.8 | | 0.02179 | 0.02718 | 0.00914 | 0.03643 | 2366 | 2964 | 598 |
| 13.0 | | 0.02155 | 0.02664 | 0.00928 | 0.03652 | 2340 | 2924 | 584 |
| 13.1 | | 0.02143 | 0.02637 | 0.00935 | 0.03656 | 2327 | 2904 | 577 |
| 13.15 | | 0.02137 | 0.02623 | 0.00939 | 0.03659 | 2320 | 2894 | 574 |
| 13.2 | | 0.02131 | 0.02610 | 0.00942 | 0.03661 | 2314 | 2883 | 569 |
| 13.5 | | 0.02096 | 0.02529 | 0.00964 | 0.03674 | 2275 | 2823 | 548 |
| Nitroglycerine C ₃ H ₅ N ₃ O ₉ | 227.1 | 0.01321 | 0.02202 | 0.01321 | 0.03963 | 1635 | 1984 | 349 |
| Carbamite C ₁₇ H ₂₀ N ₂ O | 268.3 | 0.06335 | 0.07453 | 0.00745 | 0.00373 | 8418 | 8468 | 50 |
| Mineral Jelly C ₂₀ H ₄₂ | 282.5 | 0.07079 | 0.14865 | — | — | 11252 | 11665 | 413 |
| Acetone C ₃ H ₆ O | 58.1 | 0.05165 | 0.10331 | — | 0.01722 | 7346 | 8338 | 992 |
| Diphenylamine C ₁₂ H ₁₁ N | 169.2 | 0.07092 | 0.06501 | 0.00591 | — | 9068 | 8858 | —210 |
| Picrite CH ₄ N ₄ O ₂ | 104.1 | 0.00961 | 0.03843 | 0.03843 | 0.01922 | 1992 | 2199 | 207 |
| Dinitrotoluene C ₇ H ₆ N ₂ O ₄ | 182.1 | 0.03843 | 0.03294 | 0.01098 | 0.02196 | 4709 | 4724 | 15 |
| Dibutyl- phthalate C ₁₆ H ₂₂ O ₄ | 278.3 | 0.05748 | 0.07904 | — | 0.01437 | 7389 | 8068 | 679 |
| Diamyl- phthalate C ₁₈ H ₂₆ O ₄ | 306.4 | 0.05875 | 0.08486 | — | 0.01306 | 7705 | 8383 | 678 |

TABLE 2.02

Heats of Formation of the Products of Explosion

In kilocalories per gram molecule for formation from graphite and gaseous oxygen, hydrogen and nitrogen.

(See Section 2.03. These heats of formation are always subject to revision).

| Substance | Mol. Wt. | Heats of Formation ($T = 300^\circ \text{K}$) | |
|-------------------------|----------|---|--------------------|
| | | At constant pressure | At constant volume |
| CO | 28.01 | 26.40 | 26.70 |
| CO ₂ | 44.01 | 94.03 | 94.02 |
| H ₂ O liquid | 18.02 | 68.30 | 67.40 |
| H ₂ O gas | 18.02 | 57.81 | 57.51 |
| CH ₄ | 16.04 | 17.88 | 17.28 |
| NH ₃ | 17.03 | 11.06 | 10.47 |
| NO | 30.01 | — 21.50 | — 21.50 |
| OH | 17.01 | — 5.95 | — 5.95 |
| N | 14.01 | — 84.45 | — 84.15 |
| O | 16.00 | — 59.15 | — 58.85 |
| H | 1.008 | — 51.83 | — 51.53 |

TABLE 2.03

Atomic Composition and Heats of Formation of Propellants

(See Sections 2.04, 2.05. These heats of formation are always subject to revision).

| Propellant | Atomic Composition (gm. atoms/gm.) | | | | Heat of Formation cal/gm. |
|-------------------------------|------------------------------------|--------|--------|--------|---------------------------|
| | C | H | N | O | |
| MD | .02143 | .03118 | .01004 | .03565 | 500.4 |
| W | .02156 | .02800 | .01036 | .03548 | 479.3 |
| WM | .02157 | .03033 | .01012 | .03553 | 493.5 |
| SC | .02232 | .03010 | .01046 | .03469 | 466.6 |
| HSC | .01956 | .02721 | .01078 | .03666 | 483.1 |
| A | .02465 | .03236 | .01008 | .03313 | 433.2 |
| AN | .02465 | .03236 | .01008 | .03313 | 433.2 |
| ASN | .02428 | .03299 | .00957 | .03381 | 504.2 |
| N | .01645 | .03571 | .02593 | .02520 | 292.4 |
| NQ | .01474 | .03384 | .02607 | .02647 | 307.6 |
| NFQ | .01652 | .03610 | .02591 | .02514 | 296.7 |
| NCT | .02227 | .02791 | .00897 | .03617 | 580.0 |
| NH | .02466 | .02888 | .00923 | .03409 | 513.4 |
| (Dupont) FNH/P (Dupont) | .02538 | .02993 | .00905 | .03365 | 509.8 |

The heats of formation are for C graphite at constant volume and 300° K

TABLE 2.04
Equilibrium Constants

(See Section 2.06. These data are always subject to revision).

| T°K | $K_0(T)$ | $K_1(T)$ | $K_2(T)$ | $K_3(T)$ | $K_4(T)$ | $K_5(T)$ | $K_6(T)$ |
|------|----------|---------------------|---------------------|---------------------|---------------------|--------------------|---------------------|
| 1000 | .7185 | 3×10^{-11} | 1×10^{-14} | 8×10^{-21} | 2×10^{-10} | 3×10^{-9} | 5×10^{-16} |
| 1200 | 1.406 | 7×10^{-9} | 1×10^{-11} | 2×10^{-16} | 3×10^{-8} | 2×10^{-7} | 7×10^{-13} |
| 1400 | 2.212 | 3×10^{-7} | 1×10^{-9} | 2×10^{-13} | 1×10^{-6} | 5×10^{-6} | 1×10^{-10} |
| 1600 | 3.043 | 6×10^{-6} | 5×10^{-8} | 5×10^{-11} | 2×10^{-5} | 6×10^{-5} | 5×10^{-9} |
| 1700 | 3.438 | 2×10^{-5} | 2×10^{-7} | 5×10^{-10} | 6×10^{-5} | .0002 | 2×10^{-8} |
| 1800 | 3.832 | 6×10^{-5} | 8×10^{-7} | 3×10^{-9} | .0001 | .0004 | 1×10^{-7} |
| 1900 | 4.206 | .0002 | 3×10^{-6} | 2×10^{-8} | .0003 | .0008 | 4×10^{-7} |
| 2000 | 4.574 | .0004 | 8×10^{-6} | 9×10^{-8} | .0007 | .0017 | 1×10^{-6} |
| 2100 | 4.909 | .0009 | 2×10^{-5} | 4×10^{-7} | .0015 | .0033 | 3×10^{-6} |
| 2200 | 5.235 | .0018 | 5×10^{-5} | 1×10^{-6} | .0029 | .0060 | 8×10^{-6} |
| 2300 | 5.533 | .0035 | .0001 | 5×10^{-6} | .0053 | .0103 | 2×10^{-5} |
| 2400 | 5.821 | .0063 | .0002 | 1×10^{-5} | .0091 | .0168 | 4×10^{-5} |
| 2500 | 6.081 | .0109 | .0004 | 5×10^{-5} | .0152 | .0265 | 9×10^{-5} |
| 2600 | 6.331 | .0182 | .0009 | .0001 | .0244 | .0403 | .0002 |
| 2700 | 6.552 | .0292 | .0016 | .0002 | .0378 | .0596 | .0004 |
| 2800 | 6.764 | .0453 | .0026 | .0005 | .0567 | .0856 | .0006 |
| 2900 | 6.949 | .0680 | .0043 | .0011 | .0828 | .1201 | .0010 |
| 3000 | 7.127 | .0995 | .0070 | .0023 | .1179 | .1648 | .0017 |
| 3100 | 7.281 | .1419 | .0108 | .0044 | .1639 | .2217 | .0027 |
| 3200 | 7.428 | .1981 | .0163 | .0081 | .2233 | .2926 | .0042 |
| 3300 | 7.552 | .2709 | .0240 | .0144 | .2989 | .3799 | .0063 |
| 3400 | 7.670 | .3638 | .0345 | .0248 | .3931 | .4858 | .0092 |
| 3500 | 7.764 | .4801 | .0486 | .0415 | .5094 | .6130 | .0133 |
| 3600 | 7.854 | .6236 | .0671 | .0674 | .6503 | .7631 | .0188 |
| 3700 | 7.923 | .799 | .0911 | .1065 | .820 | .940 | .0261 |
| 3800 | 7.989 | 1.009 | .1216 | .1642 | 1.021 | 1.144 | .0357 |
| 3900 | 8.037 | 1.260 | .1599 | .2478 | 1.257 | 1.380 | .0480 |
| 4000 | 8.082 | 1.556 | .2073 | .3663 | 1.531 | 1.648 | .0637 |

For the purposes of interpolation, $\log_{10} K$ is approximately a linear function of $1/T$ for T greater than 2000°K.

TABLE 2.05

Mean Molecular Heats over the Temperature Range 300° K to T°K

In calories per gram molecule per degree at constant volume.

(See Section 2.07. These data are always subject to revision).

| T°K | CO ₂ | H ₂ O | CO | H ₂ | N ₂ | OH | NO | O ₂ |
|------|-----------------|------------------|-------|----------------|----------------|-------|-------|----------------|
| 1000 | 9.409 | 6.823 | 5.403 | 5.055 | 5.326 | 5.136 | 5.592 | 5.751 |
| 1200 | 9.824 | 7.107 | 5.553 | 5.115 | 5.468 | 5.212 | 5.744 | 5.907 |
| 1400 | 10.165 | 7.388 | 5.684 | 5.189 | 5.597 | 5.298 | 5.869 | 6.037 |
| 1600 | 10.449 | 7.661 | 5.799 | 5.272 | 5.712 | 5.390 | 5.975 | 6.147 |
| 1700 | 10.577 | 7.797 | 5.852 | 5.318 | 5.766 | 5.439 | 6.024 | 6.198 |
| 1800 | 10.690 | 7.918 | 5.899 | 5.359 | 5.814 | 5.482 | 6.067 | 6.244 |
| 1900 | 10.798 | 8.044 | 5.945 | 5.405 | 5.861 | 5.529 | 6.110 | 6.290 |
| 2000 | 10.896 | 8.157 | 5.986 | 5.447 | 5.904 | 5.572 | 6.149 | 6.331 |
| 2100 | 10.990 | 8.273 | 6.012 | 5.492 | 5.945 | 5.617 | 6.186 | 6.373 |
| 2200 | 11.075 | 8.378 | 6.036 | 5.533 | 5.983 | 5.657 | 6.220 | 6.412 |
| 2300 | 11.157 | 8.484 | 6.086 | 5.577 | 6.020 | 5.700 | 6.252 | 6.452 |
| 2400 | 11.233 | 8.581 | 6.131 | 5.617 | 6.053 | 5.739 | 6.282 | 6.488 |
| 2500 | 11.306 | 8.678 | 6.162 | 5.659 | 6.086 | 5.780 | 6.310 | 6.525 |
| 2600 | 11.373 | 8.768 | 6.191 | 5.697 | 6.116 | 5.818 | 6.336 | 6.559 |
| 2700 | 11.438 | 8.857 | 6.218 | 5.736 | 6.146 | 5.856 | 6.361 | 6.594 |
| 2800 | 11.498 | 8.940 | 6.244 | 5.773 | 6.173 | 5.891 | 6.384 | 6.626 |
| 2900 | 11.556 | 9.022 | 6.269 | 5.811 | 6.199 | 5.927 | 6.406 | 6.659 |
| 3000 | 11.611 | 9.099 | 6.293 | 5.846 | 6.224 | 5.960 | 6.427 | 6.690 |
| 3100 | 11.664 | 9.174 | 6.315 | 5.882 | 6.248 | 5.993 | 6.448 | 6.722 |
| 3200 | 11.714 | 9.245 | 6.336 | 5.915 | 6.270 | 6.024 | 6.467 | 6.752 |
| 3300 | 11.762 | 9.315 | 6.357 | 5.948 | 6.292 | 6.055 | 6.486 | 6.782 |
| 3400 | 11.808 | 9.380 | 6.376 | 5.980 | 6.312 | 6.085 | 6.504 | 6.811 |
| 3500 | 11.853 | 9.444 | 6.395 | 6.012 | 6.332 | 6.115 | 6.521 | 6.840 |
| 3600 | 11.895 | 9.505 | 6.412 | 6.042 | 6.350 | 6.143 | 6.538 | 6.868 |
| 3700 | 11.936 | 9.565 | 6.429 | 6.073 | 6.368 | 6.171 | 6.554 | 6.895 |
| 3800 | 11.975 | 9.621 | 6.446 | 6.102 | 6.385 | 6.198 | 6.569 | 6.921 |
| 3900 | 12.013 | 9.677 | 6.462 | 6.131 | 6.402 | 6.225 | 6.585 | 6.947 |
| 4000 | 12.050 | 9.730 | 6.477 | 6.158 | 6.418 | 6.251 | 6.600 | 6.972 |

For interpolation the mean molecular heats are approximately linear functions of $1/T$ for T greater than 2000° K.

For monatomic gases, the mean molecular heats are 2.980 throughout.

TABLE 2.06

B and C

(See Section 2.06)

| T°K | B (c.c./gm.mol.) | | | | C (c.c./gm.mol.) ² | | | |
|------|---------------------|---------------------|-----------------|------------------|----------------------------------|---------------------|-----------------|------------------|
| | H ₂ | N ₂ , CO | CO ₂ | H ₂ O | H ₂ | N ₂ , CO | CO ₂ | H ₂ O |
| 1600 | 16.4 | 32.1 | 45.7 | -4.2 | 20 | 210 | 1385 | 220 |
| 1700 | 16.3 | 32.3 | 47.3 | -2.5 | 20 | 200 | 1305 | 210 |
| 1800 | 16.2 | 32.4 | 48.7 | -1.1 | 20 | 190 | 1235 | 195 |
| 1900 | 16.1 | 32.6 | 49.9 | +0.2 | 20 | 180 | 1170 | 185 |
| 2000 | 16.0 | 32.6 | 50.9 | 1.2 | 15 | 170 | 1110 | 175 |
| 2100 | 15.9 | 32.7 | 51.8 | 2.2 | 15 | 160 | 1055 | 170 |
| 2200 | 15.8 | 32.7 | 52.6 | 3.0 | 15 | 155 | 1010 | 160 |
| 2300 | 15.7 | 32.8 | 53.2 | 3.7 | 15 | 150 | 965 | 155 |
| 2400 | 15.6 | 32.8 | 53.8 | 4.4 | 15 | 140 | 925 | 145 |
| 2500 | 15.6 | 32.8 | 54.4 | 5.0 | 15 | 135 | 885 | 140 |
| 2600 | 15.5 | 32.7 | 54.8 | 5.5 | 15 | 130 | 855 | 135 |
| 2700 | 15.4 | 32.7 | 55.3 | 6.0 | 15 | 125 | 825 | 130 |
| 2800 | 15.3 | 32.7 | 55.6 | 6.4 | 10 | 120 | 795 | 125 |
| 2900 | 15.3 | 32.6 | 56.0 | 6.8 | 10 | 120 | 765 | 120 |
| 3000 | 15.2 | 32.6 | 56.2 | 7.1 | 10 | 115 | 740 | 120 |
| 3100 | 15.1 | 32.6 | 56.5 | 7.5 | 10 | 110 | 720 | 115 |
| 3200 | 15.0 | 32.5 | 56.7 | 7.7 | 10 | 105 | 695 | 110 |
| 3300 | 15.0 | 32.4 | 56.9 | 8.0 | 10 | 105 | 675 | 105 |
| 3400 | 14.9 | 32.4 | 57.1 | 8.3 | 10 | 100 | 650 | 105 |
| 3500 | 14.8 | 32.3 | 57.3 | 8.5 | 10 | 95 | 635 | 100 |
| 3600 | 14.8 | 32.3 | 57.4 | 8.7 | 10 | 95 | 615 | 100 |
| 3700 | 14.7 | 32.2 | 57.5 | 8.9 | 10 | 90 | 600 | 95 |
| 3800 | 14.7 | 32.2 | 57.6 | 9.1 | 10 | 90 | 585 | 95 |
| 3900 | 14.6 | 32.1 | 57.7 | 9.3 | 10 | 85 | 570 | 90 |
| 4000 | 14.5 | 32.0 | 57.8 | 9.4 | 10 | 85 | 555 | 90 |

TABLE 2.07

 ΔB and $\frac{1}{2}\Delta C$

(See Section 2.06)

| T°K | $-\Delta B$ c.c./gm.mol. | $-\frac{1}{2}\Delta C$ (c.c./gm.mol.) ² |
|------|-----------------------------|---|
| 1600 | 34.2 | 490 |
| 1700 | 33.8 | 460 |
| 1800 | 33.5 | 435 |
| 1900 | 33.2 | 410 |
| 2000 | 33.0 | 390 |
| 2100 | 32.8 | 370 |
| 2200 | 32.6 | 355 |
| 2300 | 32.5 | 340 |
| 2400 | 32.4 | 325 |
| 2500 | 32.2 | 310 |
| 2600 | 32.1 | 300 |
| 2700 | 32.0 | 290 |
| 2800 | 31.9 | 280 |
| 2900 | 31.8 | 270 |
| 3000 | 31.7 | 260 |
| 3100 | 31.6 | 255 |
| 3200 | 31.5 | 245 |
| 3300 | 31.4 | 235 |
| 3400 | 31.4 | 230 |
| 3500 | 31.3 | 225 |
| 3600 | 31.2 | 215 |
| 3700 | 31.1 | 210 |
| 3800 | 31.1 | 205 |
| 3900 | 31.0 | 200 |
| 4000 | 30.9 | 195 |

TABLE 2.08

 E_1 and E_2

(See Section 2.07)

| T° K | $E_1/100$ cal. (c.c./gm.mol.)/gm.mol. | | | |
|------|--|-----------------------|-----------------|------------------|
| | H ₂ | N ₂ and CO | CO ₂ | H ₂ O |
| 1600 | 45 | -110 | -870 | -935 |
| 1700 | 50 | -95 | -840 | -895 |
| 1800 | 55 | -80 | -810 | -855 |
| 1900 | 65 | -70 | -785 | -825 |
| 2000 | 70 | -55 | -755 | -795 |
| 2100 | 75 | -40 | -730 | -770 |
| 2200 | 80 | -25 | -700 | -745 |
| 2300 | 90 | -15 | -675 | -725 |
| 2400 | 95 | 0 | -645 | -705 |
| 2500 | 100 | 15 | -620 | -685 |
| 2600 | 105 | 25 | -595 | -665 |
| 2700 | 110 | 40 | -565 | -650 |
| 2800 | 120 | 55 | -540 | -635 |
| 2900 | 125 | 65 | -515 | -620 |
| 3000 | 130 | 80 | -490 | -605 |
| 3100 | 135 | 95 | -465 | -590 |
| 3200 | 140 | 105 | -440 | -580 |
| 3300 | 145 | 120 | -415 | -565 |
| 3400 | 150 | 130 | -390 | -555 |
| 3500 | 160 | 145 | -365 | -540 |
| 3600 | 165 | 155 | -340 | -530 |
| 3700 | 170 | 170 | -315 | -520 |
| 3800 | 175 | 185 | -290 | -510 |
| 3900 | 180 | 195 | -265 | -500 |
| 4000 | 185 | 210 | -240 | -490 |

At all temperatures in this range use

| | H ₂ | N ₂ , CO | CO ₂ | H ₂ O | |
|--------------|----------------|---------------------|-----------------|------------------|--|
| $10^{-4}E_2$ | 3 | 34 | 220 | 35 | cal. (c.c./gm. mol) ² /gm.mol. |

TABLE 2.09
Additive Constants of Propellant Constituents

(See Section 2.14. These data are always subject to revision).

| Constituent | $(C_v)_i$ | E_i | n_i |
|-------------------|-----------------------------|---------------------------|--------------------------------|
| Nitrocellulose | 0.3421 + .006 (13.15—%N) | 253.1 — 153 (13.15—%N) | 0.03920 + .00218 (13.15—%N) |
| Nitroglycerine | 0.3439 | 951.9 | 0.03083 |
| Carbamite | 0.3909 | —2765.8 | 0.10443 |
| Mineral Jelly | 0.5983 | —4175.1 | 0.14200 |
| Acetone | 0.5107 | —2842.5 | 0.10336 |
| Diphenylamine | 0.3475 | —3009.7 | 0.10645 |
| Picrite | 0.3711 | — 48.9 | 0.04805 |
| Dinitrotoluene | 0.3213 | — 668.4 | 0.06042 |
| Dibutylphthalate | 0.4261 | —2656.0 | 0.09707 |
| Diamylphthalate | 0.4408 | —2809.0 | 0.10130 |
| Potassium Nitrate | 0.2158 | 24.9 | 0.00989 |

The above table has been taken from Hirschfelder and Sherman, N.D.R.C. Report No. A—101, 1942 as amended by N.D.R.C. Armor and Ordnance Memo. No. A—67 M, 1943.

TABLE 2.10
Propellant Constants

(See Section 2.15. These data are always subject to revision).

| Propellant | Adiabatic Flame Temperature T_0 | Force Constant inch-tons/lb. F | Co-volume c. in/lb. b | Ratio of Specific Heats γ |
|----------------|--|---|-------------------------------|---|
| MD | 3220 | 2000 | 25.4 | 1.24 |
| W | 3300 | 2010 | 25.5 | 1.24 |
| WM | 3220 | 2000 | 25.5 | 1.24 |
| SC | 3090 | 1970 | 25.9 | 1.25 |
| HSC | 3630 | 2070 | 24.7 | 1.22 |
| A | 2680 | 1820 | 26.8 | 1.26 |
| AN | 2670 | 1810 | 26.8 | 1.26 |
| ASN | 2620 | 1780 | 26.5 | 1.26 |
| N | 2430 | 1760 | 27.8 | 1.27 |
| NQ | 2800 | 1900 | 27.0 | 1.25 |
| NFQ | 2410 | 1750 | 27.8 | 1.27 |
| NCT | 3010 | 1840 | 25.4 | 1.24 |
| NH (Dupont) | 2680 | 1760 | 26.5 | 1.26 |
| FNH/P (Dupont) | 2510 | 1690 | 26.8 | 1.28 |

TABLE 3.01
Functions for the Solution of the Flame Equation

(See Section 3.07)

| k | g_1 | g_2 | g_3 |
|------|-------|-------|-------|
| 4.5 | .840 | .397 | .258 |
| 3.9 | .822 | .386 | .250 |
| 3.3 | .800 | .372 | .240 |
| 2.7 | .771 | .355 | .228 |
| 2.1 | .731 | .332 | .211 |
| 1.5 | .672 | .298 | .188 |
| 1.4 | .660 | .291 | .183 |
| 1.3 | .646 | .283 | .178 |
| 1.2 | .631 | .274 | .172 |
| 1.1 | .615 | .265 | .165 |
| 1.0 | .596 | .255 | .159 |
| 0.95 | .586 | .249 | .155 |
| 0.9 | .576 | .244 | .151 |
| 0.85 | .565 | .238 | .147 |
| 0.8 | .553 | .231 | .143 |
| 0.75 | .541 | .224 | .138 |
| 0.7 | .527 | .217 | .133 |
| 0.65 | .512 | .210 | .128 |
| 0.6 | .497 | .202 | .123 |
| 0.55 | .480 | .193 | .117 |
| 0.5 | .461 | .183 | .111 |
| 0.45 | .442 | .173 | .104 |
| 0.4 | .419 | .162 | .097 |
| 0.38 | .410 | .158 | .094 |
| 0.36 | .400 | .153 | .091 |
| 0.34 | .389 | .148 | .088 |
| 0.32 | .378 | .142 | .085 |
| 0.30 | .367 | .137 | .081 |
| 0.28 | .355 | .131 | .077 |
| 0.26 | .342 | .125 | .074 |
| 0.24 | .328 | .119 | .070 |
| 0.22 | .314 | .112 | .066 |
| 0.20 | .299 | .106 | .061 |
| 0.18 | .282 | .098 | .057 |
| 0.16 | .265 | .091 | .052 |
| 0.14 | .245 | .082 | .047 |
| 0.12 | .224 | .074 | .042 |
| 0.10 | .201 | .064 | .036 |
| 0.08 | .176 | .054 | .030 |
| 0.06 | .146 | .043 | .024 |

TABLE 5.01

Rate-of-burning Indices and Coefficients with Initial Temperature Effects

The figures give the rate of reduction of the least grain dimension in inches per second when the pressure is in tons/sq. in. They are always subject to revision.

| Propellant | Pressure index α | Non-linear coefficient β | Coefficient for linear law β_1 | Effect of 10° F. variation in initial temperature | |
|----------------|----------------------------|-----------------------------------|---|---|---------------------|
| | | | | $d\beta_1/\beta_1$ per cent. | dF/F per cent. |
| MD | 0.91 | 1.50 | 1.19 | • | 0.15 |
| W | 0.97 | 1.16 | 1.08 | 1.6 | 0.15 |
| WM | 1.05 | 1.03 | 1.15 | 2.2 | 0.15 |
| SC | 1.04 | 0.91 | 1.00 | 2.0 | 0.17 |
| HSC | 0.97 | 1.63 | 1.52 | 2.0 | 0.13 |
| A | 1.11 | 0.66 | 0.84 | 1.9 | 0.18 |
| AN | 1.06 | 0.72 | 0.82 | 1.8 | 0.20 |
| ASN | 1.05 | 0.69 | 0.77 | 0.9 | 0.22 |
| N | 0.93 | 0.75 | 0.63 | 1.0 | 0.22 |
| NQ | 0.89 | 0.98 | 0.75 | 0.9 | 0.19 |
| NFQ | 0.91 | 0.79 | 0.63 | 1.0 | 0.22 |
| NCT | 0.80 | 1.46 | 0.84 | • | 0.17 |
| NH (Dupont) | 0.99 | 0.78 | 0.76 | 0.9 | 0.17 |
| FNH/P (Dupont) | 1.02 | 0.68 | 0.71 | 0.7 | 0.21 |

• There are no reliable figures available.

TABLE 8.01
Log H for Positive Values of η/a and b/a

| b/a | 0 | .01 | .02 | .04 | .06 | .08 | .10 | .15 | .20 |
|----------|-------|-------|-------|-------|-------|-------|-------|-------|-------|
| η/a | | | | | | | | | |
| 0 | .0000 | .0000 | .0000 | .0000 | .0000 | .0000 | .0000 | .0000 | .0000 |
| .02 | .0088 | .0040 | .0027 | .0017 | .0012 | .0010 | .0008 | .0006 | .0004 |
| .04 | .0177 | .0106 | .0080 | .0054 | .0041 | .0034 | .0028 | .0020 | .0016 |
| .06 | .0269 | .0182 | .0146 | .0106 | .0083 | .0069 | .0059 | .0043 | .0034 |
| .08 | .0362 | .0263 | .0218 | .0165 | .0133 | .0112 | .0097 | .0073 | .0058 |
| .10 | .0458 | .0350 | .0296 | .0231 | .0191 | .0164 | .0143 | .0109 | .0088 |
| .15 | .0706 | .0580 | .0510 | .0419 | .0358 | .0314 | .0280 | .0221 | .0183 |
| .20 | .0969 | .0829 | .0746 | .0632 | .0553 | .0493 | .0447 | .0363 | .0306 |
| .25 | .1250 | .1098 | .1004 | .0871 | .0776 | .0702 | .0642 | .0530 | .0454 |
| .30 | .1549 | .1386 | .1283 | .1132 | .1021 | .0934 | .0861 | .0723 | .0628 |
| .35 | .1872 | .1699 | .1586 | .1419 | .1294 | .1192 | .1108 | .0944 | .0827 |
| .40 | .2218 | .2036 | .1915 | .1732 | .1592 | .1477 | .1381 | .1193 | .1053 |
| .45 | .2596 | .2407 | .2277 | .2079 | .1924 | .1796 | .1688 | .1473 | .1310 |
| .50 | .3010 | .2811 | .2673 | .2459 | .2290 | .2150 | .2029 | .1787 | .1602 |
| .55 | .3468 | .3259 | .3113 | .2883 | .2700 | .2547 | .2413 | .2142 | .1934 |
| .60 | .3979 | .3762 | .3609 | .3363 | .3164 | .2995 | .2849 | .2548 | .2313 |

TABLE 8.01
—Log H for Negative Values of η/a and b/a
 When $\theta' < 0$, N and a are negative ; b is always positive.

| b/a | 0 | —.01 | —.02 | —.04 | —.06 | —.08 | —.10 | —.15 | —.20 |
|----------|-------|-------|-------|-------|-------|-------|-------|-------|-------|
| η/a | | | | | | | | | |
| 0 | .0000 | .0000 | .0000 | .0000 | .0000 | .0000 | .0000 | .0000 | .0000 |
| —.02 | .0086 | .0038 | .0026 | .0017 | .0012 | .0009 | .0008 | .0006 | .0004 |
| —.04 | .0170 | .0101 | .0077 | .0052 | .0039 | .0032 | .0027 | .0019 | .0015 |
| —.06 | .0253 | .0170 | .0136 | .0098 | .0077 | .0064 | .0054 | .0040 | .0031 |
| —.08 | .0334 | .0241 | .0198 | .0149 | .0120 | .0101 | .0088 | .0066 | .0053 |
| —.10 | .0414 | .0313 | .0263 | .0204 | .0168 | .0143 | .0126 | .0095 | .0078 |
| —.15 | .0607 | .0492 | .0430 | .0350 | .0299 | .0261 | .0232 | .0182 | .0151 |
| —.20 | .0792 | .0667 | .0596 | .0501 | .0436 | .0388 | .0350 | .0282 | .0238 |
| —.30 | .1139 | .1000 | .0916 | .0799 | .0715 | .0650 | .0597 | .0496 | .0429 |
| —.40 | .1461 | .1313 | .1221 | .1088 | .0989 | .0911 | .0847 | .0724 | .0634 |
| —.50 | .1761 | .1606 | .1508 | .1364 | .1254 | .1166 | .1092 | .0948 | .0841 |
| —.60 | .2041 | .1881 | .1779 | .1624 | .1506 | .1410 | .1329 | .1167 | .1046 |

TABLE 8.02

Critical Value of γM for Maximum PressureIf γM is greater than the value in the table a true maximum exists.If γM is less, the greatest pressure is at all-burnt.

| ζ_0 | 0.00 | 0.05 | 0.10 | 0.15 | 0.20 | 0.25 | 0.30 |
|-----------|-------|-------|-------|-------|-------|-------|-------|
| θ | | | | | | | |
| -0.2 | 1.200 | 1.278 | 1.366 | 1.462 | 1.571 | 1.692 | 1.832 |
| 0.0 | 1.000 | 1.053 | 1.111 | 1.176 | 1.250 | 1.333 | 1.429 |
| 0.2 | 0.800 | 0.836 | 0.874 | 0.918 | 0.966 | 1.022 | 1.086 |
| 0.4 | 0.600 | 0.622 | 0.647 | 0.675 | 0.706 | 0.740 | 0.778 |
| 0.6 | 0.400 | 0.413 | 0.427 | 0.443 | 0.461 | 0.480 | 0.502 |
| 0.8 | 0.200 | 0.206 | 0.212 | 0.219 | 0.227 | 0.235 | 0.244 |
| 1.0 | 0.000 | 0.000 | 0.000 | 0.000 | 0.000 | 0.000 | 0.000 |

TABLE 8.03

 $M\zeta_1'/(1 + \theta)^2$

| $M\zeta_0/(1 + \theta)^2$ | 0 | .05 | .10 | .15 | .20 | .25 | .30 | .35 | .40 |
|---------------------------|------|------|------|------|------|-------|-------|-------|-------|
| $1/N$ | | | | | | | | | |
| -0.2 | .528 | .663 | .777 | .885 | .990 | 1.093 | 1.194 | 1.294 | 1.394 |
| -0.1 | .433 | .543 | .633 | .718 | .801 | .882 | .962 | 1.042 | 1.121 |
| 0.0 | .368 | .459 | .534 | .604 | .672 | .739 | .805 | .870 | .935 |
| 0.1 | .320 | .398 | .461 | .521 | .578 | .634 | .690 | .745 | .799 |
| 0.2 | .283 | .351 | .406 | .457 | .506 | .554 | .602 | .649 | .696 |
| 0.3 | .254 | .314 | .362 | .407 | .450 | .492 | .534 | .575 | .616 |
| 0.4 | .230 | .284 | .326 | .366 | .405 | .443 | .480 | .516 | .552 |
| 0.5 | .211 | .260 | .298 | .334 | .368 | .402 | .435 | .467 | .499 |
| 0.6 | .194 | .238 | .272 | .304 | .336 | .367 | .397 | .426 | .455 |
| 0.7 | .180 | .220 | .252 | .281 | .309 | .337 | .364 | .391 | .417 |
| 0.8 | .168 | .205 | .234 | .261 | .286 | .312 | .337 | .361 | — |
| 0.9 | .157 | .192 | .218 | .243 | .267 | .290 | .313 | — | — |
| 1.0 | .148 | .180 | .205 | .228 | .250 | .271 | — | — | — |

Approximately,

$$\frac{M\zeta_1'}{(1 + \theta)^2} = \frac{.368 + 1.27y + y/(18.5y + 0.7)}{1 + (1.5 + 0.6y)/N}$$

where $y = M\zeta_0/(1 + \theta)^2$

TABLE 8.04

$$\eta_2/M$$

| ζ_0 | 0.00 | 0.05 | 0.10 | 0.15 | 0.20 | 0.25 | 0.30 |
|-----------|-------|------|------|------|------|------|------|
| θ | | | | | | | |
| -0.2 | 1.000 | .939 | .879 | .821 | .764 | .709 | .655 |
| 0.0 | 1.000 | .950 | .900 | .850 | .800 | .750 | .700 |
| 0.2 | 1.000 | .958 | .915 | .872 | .828 | .783 | .737 |
| 0.4 | 1.000 | .964 | .927 | .889 | .850 | .811 | .771 |
| 0.6 | 1.000 | .968 | .936 | .903 | .868 | .833 | .797 |
| 0.8 | 1.000 | .972 | .943 | .913 | .883 | .851 | .819 |
| 1.0 | 1.000 | .975 | .949 | .922 | .894 | .866 | .837 |

TABLE 8.05

$$(\xi_2')^{1-\gamma} = 1 - (\gamma - 1) MJ - KY$$

J

| θ | ζ_0 | .00 | .01 | .02 | .04 | .06 | .08 | .10 | .15 | .20 | .25 | .30 |
|----------|-----------|-----|-----|-----|-----|-----|-----|-----|-----|-----|-----|-----|
| -0.2 | .790 | 766 | 743 | 699 | 658 | 619 | 583 | 495 | 417 | 350 | 292 | |
| 0.0 | .750 | 729 | 710 | 676 | 643 | 611 | 581 | 508 | 441 | 380 | 324 | |
| 0.2 | .714 | 696 | 681 | 653 | 625 | 599 | 574 | 512 | 455 | 401 | 349 | |
| 0.4 | .682 | 667 | 654 | 630 | 607 | 585 | 563 | 511 | 462 | 415 | 369 | |
| 0.6 | .653 | 640 | 629 | 608 | 589 | 570 | 551 | 506 | 463 | 422 | 383 | |
| 0.8 | .627 | 616 | 606 | 588 | 572 | 555 | 539 | 500 | 462 | 426 | 391 | |
| 0.1 | .603 | 593 | 585 | 569 | 554 | 540 | 526 | 491 | 458 | 426 | 394 | |

K

| | | | | | | | | | | | |
|------|------|-----|-----|-----|-----|-----|-----|-----|-----|-----|-----|
| -0.2 | .079 | 068 | 059 | 046 | 037 | 029 | 022 | 013 | 008 | 005 | 003 |
| 0.0 | .063 | 055 | 049 | 040 | 033 | 027 | 022 | 015 | 009 | 006 | 004 |
| 0.2 | .050 | 044 | 040 | 034 | 028 | 024 | 021 | 015 | 010 | 007 | 004 |
| 0.4 | .040 | 036 | 033 | 029 | 024 | 021 | 019 | 014 | 009 | 006 | 004 |
| 0.4 | .033 | 030 | 027 | 024 | 021 | 019 | 017 | 012 | 009 | 006 | 004 |
| 0.8 | .027 | 025 | 023 | 020 | 018 | 016 | 015 | 011 | 008 | 006 | 004 |
| 1.0 | .023 | 021 | 019 | 017 | 016 | 014 | 012 | 010 | 008 | 006 | 004 |

Y

| $(\gamma-1)M$ | 0.0 | 0.1 | 0.2 | 0.3 | 0.4 | 0.5 | 0.6 | 0.7 | 0.8 | 0.9 | 1.0 |
|---------------|-----|-----|-----|-----|-----|-----|-----|-----|-----|-----|-----|
| Y | .00 | .35 | .65 | .85 | .95 | 1.0 | .95 | .85 | .65 | .35 | .00 |

TABLE 8.06

$$1/\Phi' = 1 - (\gamma - 1)MI + Gy$$

I

| θ | ζ_0 | .00 | .01 | .02 | .03 | .04 | .05 | .06 | .07 | .08 | .09 | .10 | .15 | .20 | .25 | .30 |
|----------|-----------|-----|-----|-----|-----|-----|-----|-----|-----|-----|-----|-----|-----|-----|-----|-----|
| -0.2 | .583 | 541 | 508 | 478 | 450 | 424 | 400 | 378 | 356 | 336 | 317 | 237 | 177 | 131 | 096 | |
| -0.1 | .540 | 504 | 475 | 449 | 424 | 401 | 380 | 361 | 342 | 324 | 307 | 235 | 178 | 135 | 101 | |
| 0.0 | .500 | 468 | 443 | 420 | 399 | 379 | 360 | 343 | 326 | 310 | 295 | 230 | 178 | 137 | 104 | |
| 0.1 | .462 | 434 | 412 | 392 | 374 | 356 | 339 | 324 | 309 | 294 | 280 | 222 | 175 | 136 | 104 | |
| 0.2 | .426 | 402 | 382 | 365 | 349 | 333 | 318 | 304 | 291 | 278 | 265 | 212 | 170 | 134 | 104 | |
| .03 | .393 | 372 | 354 | 338 | 324 | 310 | 297 | 284 | 272 | 261 | 250 | 202 | 164 | 131 | 103 | |
| 0.4 | .362 | 343 | 327 | 313 | 300 | 288 | 276 | 265 | 254 | 244 | 234 | 191 | 156 | 126 | 101 | |
| 0.5 | .333 | 315 | 301 | 288 | 276 | 265 | 255 | 245 | 236 | 227 | 218 | 180 | 148 | 121 | 098 | |
| 0.6 | .306 | 288 | 276 | 264 | 253 | 244 | 235 | 226 | 218 | 210 | 202 | 168 | 139 | 114 | 093 | |
| 0.7 | .279 | 263 | 252 | 241 | 231 | 223 | 215 | 207 | 200 | 192 | 185 | 156 | 129 | 107 | 087 | |
| 0.8 | .253 | 239 | 229 | 219 | 210 | 203 | 196 | 189 | 182 | 175 | 169 | 143 | 119 | 099 | 081 | |
| 0.9 | .229 | 216 | 207 | 198 | 190 | 183 | 177 | 171 | 165 | 159 | 153 | 129 | 108 | 090 | 074 | |
| 1.0 | .206 | 195 | 186 | 179 | 172 | 165 | 159 | 153 | 148 | 143 | 138 | 115 | 097 | 081 | 067 | |

G

| | | | | | | | | | | | | | | | |
|------|-------|------|-----|-----|-----|-----|-----|-----|-----|-----|-----|-----|-----|-----|-----|
| -0.2 | -0.10 | -003 | 000 | 003 | 005 | 006 | 007 | 008 | 008 | 008 | 007 | 007 | 005 | 003 | 001 |
| 0.0 | -000 | 004 | 005 | 006 | 007 | 007 | 008 | 008 | 008 | 008 | 008 | 007 | 005 | 004 | 003 |
| 0.2 | .004 | 007 | 007 | 008 | 009 | 009 | 009 | 009 | 009 | 008 | 008 | 007 | 005 | 004 | 003 |
| 0.4 | .006 | 007 | 008 | 008 | 009 | 009 | 009 | 009 | 008 | 008 | 008 | 007 | 005 | 004 | 003 |
| 0.6 | .006 | 007 | 008 | 008 | 008 | 008 | 008 | 008 | 008 | 008 | 008 | 007 | 005 | 004 | 003 |
| 0.8 | .005 | 006 | 006 | 006 | 006 | 006 | 006 | 006 | 006 | 006 | 006 | 005 | 004 | 003 | 002 |
| 1.0 | .004 | 004 | 004 | 004 | 004 | 004 | 004 | 004 | 004 | 004 | 004 | 003 | 002 | 002 | 001 |

y

| | | | | | | | | | | | |
|---------------|-----|----|----|----|----|-----|-----|----|----|----|-----|
| $(\gamma-1)M$ | 0.0 | .1 | .2 | .3 | .4 | .5 | .6 | .7 | .8 | .9 | 1.0 |
| y | 0 | .3 | .6 | .8 | .9 | 1.0 | 1.0 | .9 | .8 | .4 | 0 |

TABLE 8.07

XY^{-1}

| γ | 1.20 | 1.22 | 1.24 | 1.26 | 1.28 | 1.30 |
|----------|-------|-------|-------|-------|-------|-------|
| X | | | | | | |
| 1.0 | 1.000 | 1.000 | 1.000 | 1.000 | 1.000 | 1.000 |
| 1.5 | 1.084 | 1.093 | 1.102 | 1.111 | 1.120 | 1.129 |
| 2.0 | 1.149 | 1.165 | 1.181 | 1.197 | 1.214 | 1.231 |
| 2.5 | 1.201 | 1.223 | 1.246 | 1.269 | 1.292 | 1.316 |
| 3.0 | 1.246 | 1.273 | 1.302 | 1.331 | 1.360 | 1.390 |
| 3.5 | 1.285 | 1.317 | 1.351 | 1.385 | 1.420 | 1.456 |
| 4.0 | 1.320 | 1.357 | 1.395 | 1.434 | 1.474 | 1.516 |
| 4.5 | 1.351 | 1.392 | 1.435 | 1.479 | 1.524 | 1.570 |
| 5.0 | 1.380 | 1.425 | 1.471 | 1.520 | 1.569 | 1.621 |
| 6.0 | 1.431 | 1.483 | 1.537 | 1.593 | 1.652 | 1.712 |
| 7.0 | 1.476 | 1.534 | 1.595 | 1.659 | 1.724 | 1.793 |
| 8.0 | 1.516 | 1.580 | 1.647 | 1.717 | 1.790 | 1.866 |
| 9.0 | 1.552 | 1.622 | 1.694 | 1.771 | 1.850 | 1.933 |
| 10.0 | 1.585 | 1.660 | 1.738 | 1.820 | 1.905 | 1.995 |
| 11.0 | 1.615 | 1.695 | 1.778 | 1.865 | 1.957 | 2.053 |
| 12.0 | 1.644 | 1.728 | 1.816 | 1.908 | 2.005 | 2.107 |
| 13.0 | 1.670 | 1.758 | 1.851 | 1.948 | 2.051 | 2.159 |
| 14.0 | 1.695 | 1.787 | 1.884 | 1.986 | 2.094 | 2.207 |
| 15.0 | 1.719 | 1.814 | 1.915 | 2.022 | 2.135 | 2.253 |

TABLE 8.08

Propellant Data in British Units for Linear-law Calculations

(See Chapter VIII. These data are always subject to revision).

| Propellant | $1/\delta$ | $b-1/\delta$ | $\frac{8.653 \times 10^5}{F\beta^2}$ | γ | F | $\frac{12020 F}{(\gamma-1) \times 10^5}$ |
|-------------------|------------|--------------|--------------------------------------|----------|------|--|
| MD | 17.5 | 7.9 | 306 | 1.24 | 2000 | 1002 |
| W | 17.3 | 8.2 | 369 | 1.24 | 2010 | 1007 |
| WM | 17.4 | 8.1 | 327 | 1.24 | 2000 | 1002 |
| SC | 17.6 | 8.3 | 439 | 1.25 | 1970 | 947 |
| HSC | 17.2 | 7.5 | 181 | 1.22 | 2070 | 1131 |
| A | 18.0 | 8.8 | 674 | 1.26 | 1820 | 841 |
| AN | 18.0 | 8.8 | 710 | 1.26 | 1810 | 837 |
| ASN | 17.6 | 8.9 | 820 | 1.26 | 1780 | 823 |
| N | 16.7 | 11.1 | 1239 | 1.27 | 1760 | 784 |
| NQ | 16.5 | 10.5 | 810 | 1.25 | 1900 | 914 |
| NFQ | 16.9 | 10.9 | 1246 | 1.27 | 1750 | 779 |
| NCT | 17.1 | 8.3 | 667 | 1.24 | 1840 | 922 |
| NH | 17.6 | 8.9 | 851 | 1.26 | 1760 | 814 |
| (Dupont) FNH/P | 17.6 | 9.2 | 1016 | 1.28 | 1690 | 725 |
| (Dupont) | | | | | | |

TABLE 8.09
Ounces and Drams as Decimals of a Pound

| Drs. Ozs. | 0 | 1 | 2 | 3 | 4 | 5 | 6 | 7 | 8 | 9 | 10 | 11 | 12 | 13 | 14 | 15 |
|--------------|------|------|------|------|------|------|------|------|------|------|------|------|------|------|------|------|
| 0 | .000 | .004 | .008 | .012 | .016 | .019 | .023 | .027 | .031 | .035 | .039 | .043 | .047 | .051 | .055 | .059 |
| 1 | .062 | .066 | .070 | .074 | .078 | .082 | .086 | .090 | .094 | .098 | .102 | .105 | .109 | .113 | .117 | .121 |
| 2 | .125 | .129 | .133 | .137 | .141 | .144 | .148 | .152 | .156 | .160 | .164 | .168 | .172 | .176 | .180 | .184 |
| 3 | .187 | .191 | .195 | .199 | .203 | .207 | .211 | .215 | .219 | .223 | .227 | .230 | .234 | .238 | .242 | .246 |
| 4 | .250 | .254 | .258 | .262 | .266 | .270 | .273 | .277 | .281 | .285 | .289 | .293 | .297 | .301 | .305 | .309 |
| 5 | .312 | .316 | .320 | .324 | .328 | .332 | .336 | .340 | .344 | .348 | .352 | .355 | .359 | .363 | .367 | .371 |
| 6 | .375 | .379 | .383 | .387 | .391 | .394 | .398 | .402 | .406 | .410 | .414 | .418 | .422 | .426 | .430 | .434 |
| 7 | .437 | .441 | .445 | .449 | .453 | .457 | .461 | .465 | .469 | .473 | .477 | .480 | .484 | .488 | .492 | .496 |
| 8 | .500 | .504 | .508 | .512 | .516 | .520 | .523 | .527 | .531 | .535 | .539 | .543 | .547 | .551 | .555 | .559 |
| 9 | .562 | .566 | .570 | .574 | .578 | .582 | .586 | .590 | .594 | .598 | .602 | .605 | .609 | .613 | .617 | .621 |
| 10 | .625 | .629 | .633 | .637 | .641 | .645 | .648 | .652 | .656 | .660 | .664 | .668 | .672 | .676 | .680 | .684 |
| 11 | .687 | .691 | .695 | .699 | .703 | .707 | .711 | .715 | .719 | .723 | .727 | .730 | .734 | .738 | .742 | .746 |
| 12 | .750 | .754 | .758 | .762 | .766 | .770 | .773 | .777 | .781 | .785 | .789 | .793 | .797 | .801 | .805 | .809 |
| 13 | .812 | .816 | .820 | .824 | .828 | .832 | .836 | .840 | .844 | .848 | .852 | .855 | .859 | .863 | .867 | .871 |
| 14 | .875 | .879 | .883 | .887 | .891 | .895 | .898 | .902 | .906 | .910 | .914 | .918 | .922 | .926 | .930 | .934 |
| 15 | .937 | .941 | .945 | .949 | .953 | .957 | .961 | .965 | .969 | .973 | .977 | .980 | .984 | .988 | .992 | .996 |

TABLE 10.01
Ballistic Functions for NCT

$$\gamma = 1.24 \quad \alpha = 0.8$$

(See Section 10.03)

| Z | X | dX/dZ | I(Z) | $\xi = X^m$ | $M^n \zeta$ | V(Z) |
|-----|-------|-------|-------|-------------|-------------|-------|
| 0.0 | 1.000 | 1.000 | 0.000 | 1.000 | .000 | 0.000 |
| 0.1 | 1.099 | 0.973 | 0.557 | 1.292 | .418 | 0.403 |
| 0.2 | 1.195 | 0.949 | 0.892 | 1.623 | .515 | 0.690 |
| 0.3 | 1.288 | 0.927 | 1.165 | 1.992 | .533 | 0.931 |
| 0.4 | 1.380 | 0.906 | 1.402 | 2.400 | .519 | 1.140 |
| 0.5 | 1.470 | 0.888 | 1.613 | 2.848 | .493 | 1.324 |
| 0.6 | 1.558 | 0.870 | 1.804 | 3.334 | .461 | 1.489 |
| 0.7 | 1.644 | 0.854 | 1.980 | 3.860 | .430 | 1.638 |
| 0.8 | 1.728 | 0.839 | 2.143 | 4.425 | .399 | 1.775 |
| 0.9 | 1.812 | 0.825 | 2.296 | 5.029 | .370 | 1.901 |
| 1.0 | 1.893 | 0.812 | 2.440 | 5.665 | .344 | 2.018 |
| 1.1 | 1.974 | 0.799 | 2.575 | 6.348 | .320 | 2.127 |
| 1.2 | 2.053 | 0.787 | 2.704 | 7.060 | .299 | 2.229 |
| 1.3 | 2.131 | 0.776 | 2.827 | 7.812 | .279 | 2.324 |
| 1.4 | 2.208 | 0.765 | 2.944 | 8.598 | .261 | 2.414 |
| 1.5 | 2.284 | 0.755 | 3.056 | 9.432 | .245 | 2.499 |
| 1.6 | 2.359 | 0.745 | 3.163 | 10.30 | .230 | 2.580 |
| 1.7 | 2.433 | 0.736 | 3.267 | 11.19 | .216 | 2.657 |
| 1.8 | 2.507 | 0.727 | 3.367 | 12.14 | .204 | 2.730 |
| 1.9 | 2.579 | 0.718 | 3.464 | 13.11 | .192 | 2.800 |
| 2.0 | 2.650 | 0.710 | 3.557 | 14.12 | .182 | 2.867 |

Pressure is maximum when $Z = 0.2935$

$$M^n \zeta_1 = G(\gamma, \alpha) = 0.5331$$

$$n = 0.7143$$

$$m = 2.717$$

$$(1 + n)/n(\gamma - n) = 4.565$$

$$[(1 + n)/n(\gamma - n)]^n = 2.958$$

TABLE 15.01
Significance Test
 Table of t
 (See Section 15.04)

| Degrees of Freedom | t | | | | |
|--------------------------|-----------------------|-------|-------|-------|--------|
| | Level of Significance | | | | |
| | 0.10 | 0.05 | 0.02 | 0.01 | 0.001 |
| 1 | 6.31 | 12.71 | 31.82 | 63.66 | 636.62 |
| 2 | 2.92 | 4.30 | 6.97 | 9.93 | 31.60 |
| 3 | 2.35 | 3.18 | 4.54 | 5.84 | 12.94 |
| 4 | 2.13 | 2.78 | 3.75 | 4.60 | 8.61 |
| 5 | 2.02 | 2.57 | 3.37 | 4.03 | 6.86 |
| 6 | 1.94 | 2.45 | 3.14 | 3.71 | 5.96 |
| 7 | 1.90 | 2.37 | 3.00 | 3.50 | 5.41 |
| 8 | 1.86 | 2.31 | 2.90 | 3.36 | 5.04 |
| 9 | 1.83 | 2.26 | 2.82 | 3.25 | 4.78 |
| 10 | 1.81 | 2.23 | 2.76 | 3.17 | 4.59 |
| 11 | 1.80 | 2.20 | 2.72 | 3.11 | 4.44 |
| 12 | 1.78 | 2.18 | 2.68 | 3.06 | 4.32 |
| 13 | 1.77 | 2.16 | 2.65 | 3.01 | 4.22 |
| 14 | 1.76 | 2.15 | 2.62 | 2.98 | 4.14 |
| 15 | 1.75 | 2.13 | 2.60 | 2.95 | 4.07 |
| 16 | 1.75 | 2.12 | 2.58 | 2.92 | 4.02 |
| 17 | 1.74 | 2.11 | 2.57 | 2.90 | 3.97 |
| 18 | 1.73 | 2.10 | 2.55 | 2.88 | 3.92 |
| 19 | 1.73 | 2.09 | 2.54 | 2.86 | 3.88 |
| 20 | 1.73 | 2.09 | 2.53 | 2.85 | 3.85 |
| 21 | 1.72 | 2.08 | 2.52 | 2.83 | 3.82 |
| 22 | 1.72 | 2.07 | 2.51 | 2.82 | 3.79 |
| 23 | 1.71 | 2.07 | 2.50 | 2.81 | 3.77 |
| 24 | 1.71 | 2.06 | 2.49 | 2.80 | 3.75 |
| 25 | 1.71 | 2.06 | 2.48 | 2.79 | 3.73 |
| 26 | 1.71 | 2.06 | 2.48 | 2.78 | 3.71 |
| 27 | 1.70 | 2.05 | 2.47 | 2.77 | 3.69 |
| 28 | 1.70 | 2.05 | 2.47 | 2.76 | 3.67 |
| 29 | 1.70 | 2.04 | 2.46 | 2.76 | 3.66 |
| 30 | 1.70 | 2.04 | 2.46 | 2.75 | 3.65 |
| 40 | 1.68 | 2.02 | 2.42 | 2.70 | 3.55 |
| 60 | 1.67 | 2.00 | 2.39 | 2.66 | 3.46 |
| 120 | 1.66 | 1.98 | 2.36 | 2.62 | 3.37 |
| ∞ | 1.65 | 1.96 | 2.33 | 2.58 | 3.29 |

Abridged from Table III of "Statistical Tables for Biological, Agricultural and Medical Research." (R. A. Fisher and F. Yates: Oliver and Boyd).

TABLE 15.02
Variance Ratios
 (See Section 15.04)
 Table of F

| | | | | | | | | | |
|------------------|---|---|---|---|---|---|----|----|----------|
| $m \backslash n$ | 1 | 2 | 3 | 4 | 5 | 6 | 12 | 24 | ∞ |
|------------------|---|---|---|---|---|---|----|----|----------|

0.20 Significance Level

| | | | | | | | | | |
|----------|-----|------|------|------|------|------|------|------|------|
| 1 | 9.5 | 12.0 | 13.1 | 13.7 | 14.0 | 14.3 | 14.9 | 15.2 | 15.6 |
| 2 | 3.6 | 4.0 | 4.2 | 4.3 | 4.3 | 4.3 | 4.3 | 4.4 | 4.5 |
| 3 | 2.7 | 2.9 | 2.9 | 3.0 | 3.0 | 3.0 | 3.0 | 3.0 | 3.0 |
| 4 | 2.4 | 2.5 | 2.5 | 2.5 | 2.5 | 2.5 | 2.5 | 2.4 | 2.4 |
| 5 | 2.2 | 2.3 | 2.3 | 2.2 | 2.2 | 2.2 | 2.2 | 2.2 | 2.1 |
| 6 | 2.1 | 2.1 | 2.1 | 2.1 | 2.1 | 2.1 | 2.0 | 2.0 | 2.0 |
| 7 | 2.0 | 2.0 | 2.0 | 2.0 | 2.0 | 2.0 | 1.9 | 1.9 | 1.8 |
| 8 | 2.0 | 2.0 | 2.0 | 1.9 | 1.9 | 1.9 | 1.8 | 1.8 | 1.7 |
| 9 | 1.9 | 1.9 | 1.9 | 1.9 | 1.9 | 1.8 | 1.8 | 1.7 | 1.7 |
| 10 | 1.9 | 1.9 | 1.9 | 1.8 | 1.8 | 1.8 | 1.7 | 1.7 | 1.6 |
| 15 | 1.8 | 1.8 | 1.8 | 1.7 | 1.7 | 1.7 | 1.6 | 1.5 | 1.5 |
| 20 | 1.8 | 1.8 | 1.7 | 1.7 | 1.6 | 1.6 | 1.5 | 1.5 | 1.4 |
| 30 | 1.7 | 1.7 | 1.6 | 1.6 | 1.6 | 1.5 | 1.5 | 1.4 | 1.3 |
| 40 | 1.7 | 1.7 | 1.6 | 1.6 | 1.5 | 1.5 | 1.4 | 1.4 | 1.2 |
| 60 | 1.7 | 1.7 | 1.6 | 1.6 | 1.5 | 1.5 | 1.4 | 1.3 | 1.2 |
| 120 | 1.7 | 1.6 | 1.6 | 1.5 | 1.5 | 1.5 | 1.4 | 1.3 | 1.1 |
| ∞ | 1.6 | 1.6 | 1.6 | 1.5 | 1.5 | 1.4 | 1.3 | 1.2 | 1.0 |

0.05 Significance Level

| | | | | | | | | | |
|----------|-------|-------|-------|-------|-------|-------|-------|-------|-------|
| 1 | 164.4 | 199.5 | 215.7 | 224.6 | 230.2 | 234.0 | 234.9 | 249.0 | 254.3 |
| 2 | 18.5 | 19.2 | 19.2 | 19.3 | 19.3 | 19.3 | 19.4 | 19.5 | 19.5 |
| 3 | 10.1 | 9.6 | 9.3 | 9.1 | 9.0 | 8.9 | 8.7 | 8.6 | 8.5 |
| 4 | 7.7 | 6.9 | 6.6 | 6.4 | 6.3 | 6.2 | 5.9 | 5.8 | 5.6 |
| 5 | 6.6 | 5.8 | 5.4 | 5.2 | 5.1 | 5.0 | 4.7 | 4.5 | 4.4 |
| 6 | 6.0 | 5.1 | 4.8 | 4.5 | 4.4 | 4.3 | 4.0 | 3.8 | 3.7 |
| 7 | 5.6 | 4.7 | 4.4 | 4.1 | 4.0 | 3.9 | 3.6 | 3.4 | 3.2 |
| 8 | 5.3 | 4.5 | 4.1 | 3.8 | 3.7 | 3.6 | 3.3 | 3.1 | 2.9 |
| 9 | 5.1 | 4.3 | 3.9 | 3.6 | 3.5 | 3.4 | 3.1 | 2.9 | 2.7 |
| 10 | 5.0 | 4.1 | 3.7 | 3.5 | 3.3 | 3.2 | 2.9 | 2.7 | 2.5 |
| 15 | 4.5 | 3.7 | 3.3 | 3.1 | 2.9 | 2.8 | 2.5 | 2.3 | 2.1 |
| 20 | 4.4 | 3.5 | 3.1 | 2.9 | 2.7 | 2.6 | 2.3 | 2.1 | 1.8 |
| 30 | 4.2 | 3.3 | 2.9 | 2.7 | 2.5 | 2.4 | 2.1 | 1.9 | 1.6 |
| 40 | 4.1 | 3.2 | 2.9 | 2.6 | 2.5 | 2.3 | 2.0 | 1.8 | 1.5 |
| 60 | 4.0 | 3.2 | 2.8 | 2.5 | 2.4 | 2.3 | 1.9 | 1.7 | 1.4 |
| 120 | 3.9 | 3.1 | 2.7 | 2.5 | 2.3 | 2.2 | 1.8 | 1.6 | 1.3 |
| ∞ | 3.8 | 3.0 | 2.6 | 2.4 | 2.2 | 2.1 | 1.8 | 1.5 | 1.0 |

Abridged from Table V of "Statistical Tables for Biological, Agricultural and Medical Research." (R. A. Fisher and F. Yates: Oliver and Boyd).

TABLE 15.02—*continued.*

| | | | | | | | | | |
|------------------|---|---|---|---|---|---|----|----|----------|
| $n \backslash m$ | 1 | 2 | 3 | 4 | 5 | 6 | 12 | 24 | ∞ |
|------------------|---|---|---|---|---|---|----|----|----------|

0.01 Significance Level

| | | | | | | | | | |
|----------|------|------|------|------|------|------|------|------|------|
| 1 | 4052 | 4999 | 5403 | 5625 | 5764 | 5859 | 6106 | 6234 | 6366 |
| 2 | 98.5 | 99.0 | 99.2 | 99.3 | 99.3 | 99.4 | 99.4 | 99.5 | 99.5 |
| 3 | 34.1 | 30.8 | 29.5 | 28.7 | 28.2 | 27.9 | 27.1 | 26.6 | 26.1 |
| 4 | 21.2 | 18.0 | 16.7 | 16.0 | 15.5 | 15.2 | 14.4 | 13.9 | 13.5 |
| 5 | 16.3 | 13.3 | 12.1 | 11.4 | 11.0 | 10.7 | 9.9 | 9.5 | 9.0 |
| 6 | 13.7 | 10.9 | 9.8 | 9.2 | 8.8 | 8.5 | 7.7 | 7.3 | 6.9 |
| 7 | 12.3 | 9.6 | 8.5 | 7.9 | 7.5 | 7.2 | 6.5 | 6.1 | 5.7 |
| 8 | 11.3 | 8.7 | 7.6 | 7.0 | 6.6 | 6.4 | 5.7 | 5.3 | 4.9 |
| 9 | 10.6 | 8.0 | 7.0 | 6.4 | 6.1 | 5.8 | 5.1 | 4.7 | 4.3 |
| 10 | 10.0 | 7.6 | 6.6 | 6.0 | 5.6 | 5.4 | 4.7 | 4.3 | 3.9 |
| 15 | 8.7 | 6.4 | 5.4 | 4.9 | 4.6 | 4.3 | 3.7 | 3.3 | 2.9 |
| 20 | 8.1 | 5.9 | 4.9 | 4.4 | 4.1 | 3.9 | 3.2 | 2.9 | 2.4 |
| 30 | 7.6 | 5.4 | 4.5 | 4.0 | 3.7 | 3.5 | 2.8 | 2.5 | 2.0 |
| 40 | 7.3 | 5.2 | 4.3 | 3.8 | 3.5 | 3.3 | 2.7 | 2.3 | 1.8 |
| 60 | 7.1 | 5.0 | 4.1 | 3.7 | 3.3 | 3.1 | 2.5 | 2.1 | 1.6 |
| 120 | 6.9 | 4.8 | 4.0 | 3.5 | 3.2 | 3.0 | 2.3 | 2.0 | 1.4 |
| ∞ | 6.6 | 4.6 | 3.8 | 3.3 | 3.0 | 2.8 | 2.2 | 1.8 | 1.0 |

0.001 Significance Level

| | | | | | | | | | |
|----------|---------------------------------|------|------|------|------|------|------|------|------|
| 1 | Varying from 400,000 to 600,000 | | | | | | | | |
| 2 | 998 | 999 | 999 | 999 | 999 | 999 | 999 | 999 | 999 |
| 3 | 167 | 148 | 141 | 137 | 135 | 133 | 128 | 126 | 123 |
| 4 | 74.1 | 61.3 | 56.2 | 53.4 | 51.7 | 50.5 | 47.4 | 45.8 | 44.1 |
| 5 | 47.0 | 36.6 | 33.2 | 31.1 | 29.8 | 28.8 | 26.4 | 25.1 | 23.8 |
| 6 | 35.5 | 27.0 | 23.7 | 21.9 | 20.8 | 20.0 | 18.0 | 16.9 | 15.8 |
| 7 | 29.2 | 21.7 | 18.8 | 17.2 | 16.2 | 15.5 | 13.7 | 12.7 | 11.7 |
| 8 | 25.4 | 18.5 | 15.8 | 14.4 | 13.5 | 12.9 | 11.2 | 10.3 | 9.3 |
| 9 | 22.9 | 16.4 | 13.9 | 12.6 | 11.7 | 11.1 | 9.6 | 8.7 | 7.8 |
| 10 | 21.0 | 14.9 | 12.6 | 11.3 | 10.5 | 9.9 | 8.5 | 7.6 | 6.8 |
| 15 | 16.6 | 11.3 | 9.3 | 8.3 | 7.6 | 7.1 | 5.8 | 5.1 | 4.3 |
| 20 | 14.8 | 10.0 | 8.1 | 7.1 | 6.5 | 6.0 | 4.8 | 4.2 | 3.4 |
| 30 | 13.3 | 8.8 | 7.1 | 6.1 | 5.5 | 5.1 | 4.0 | 3.4 | 2.6 |
| 40 | 12.6 | 8.2 | 6.6 | 5.7 | 5.1 | 4.7 | 3.6 | 3.0 | 2.2 |
| 60 | 12.0 | 7.8 | 6.2 | 5.3 | 4.8 | 4.4 | 3.3 | 2.7 | 1.9 |
| 120 | 11.4 | 7.3 | 5.8 | 5.0 | 4.4 | 4.0 | 3.0 | 2.4 | 1.6 |
| ∞ | 10.8 | 6.9 | 5.4 | 4.6 | 4.1 | 3.7 | 2.7 | 2.1 | 1.0 |

Abridged from Table V of "Statistical Tables for Biological, Agricultural and Medical Research." (R. A. Fisher and F. Yates : Oliver and Boyd).

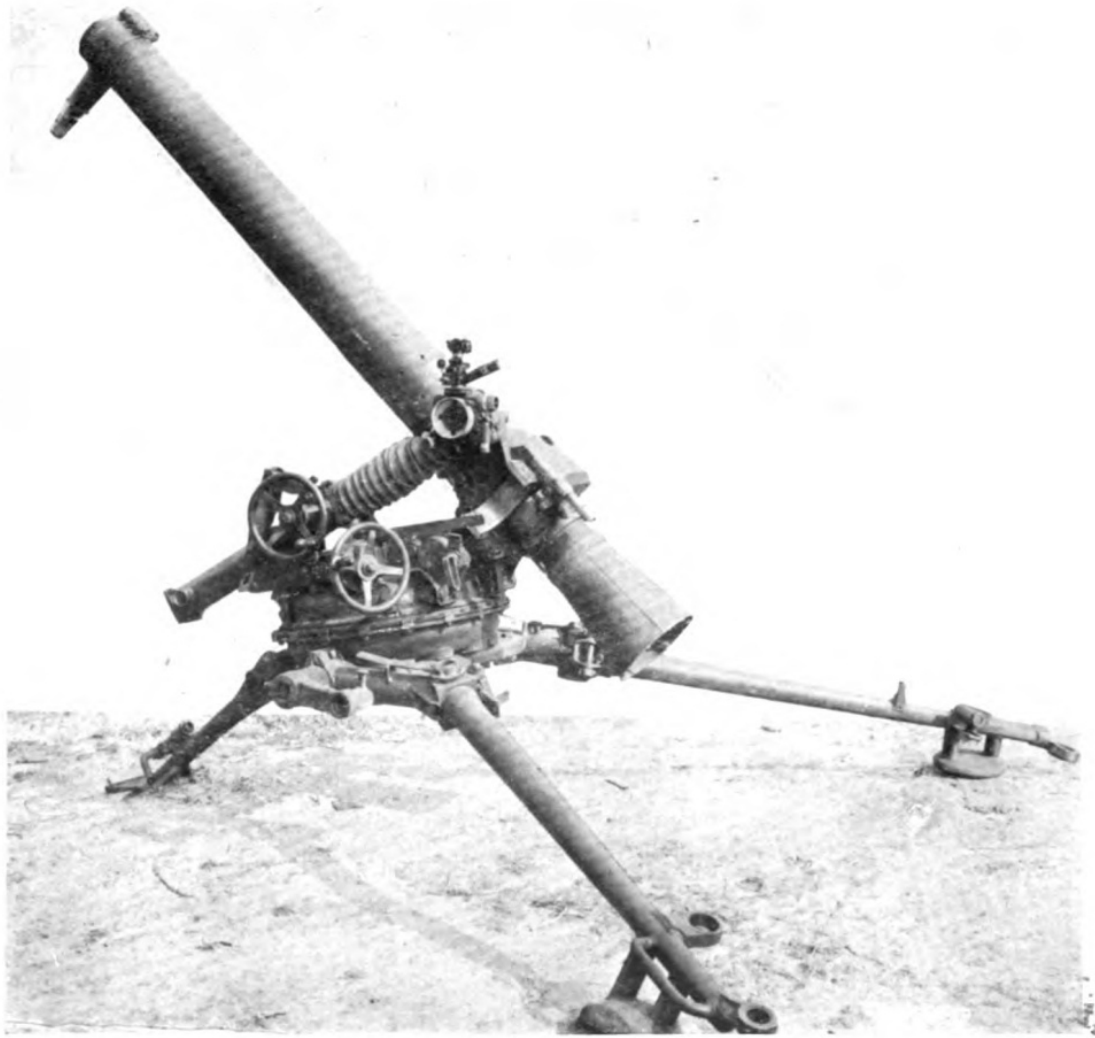

Fig. A.1. A German 15-cm. recoilless gun. Weighing only 1,400 lb. in action, it fired an 84-lb. shell at 1020 f/s.

APPENDIX I

The Theory of Leaking Guns

Up to 1943, when the author began to study this field, no such theory had been published. It is now known that parallel work was being carried out at the same time, by Hirschfelder and by Vinti in America, and by Strecke in Germany. Up to the present time, the only open publication of theoretical work in this field is a paper by the writer.*

There are at least three applications of these theories. Firstly, we can calculate the ballistics of a worn orthodox gun, in which gas is able to leak past the projectile in the earliest stages of its motion. A second application, also to be discussed in this Appendix, is to smooth-bore guns without obturating device on the shot; the most familiar example is the muzzle-loading smooth-bore mortar. Here the leakage of gas lowers the muzzle velocity, an effect which would be of little consequence if the leakage area were the same in every round. As things are, the round-to-round variations in the bomb diameter cause a dispersion in velocity. Although the effect was known, its quantitative evaluation had not been attempted before the treatment sketched in Section A.09 was published. This has been of value in deciding the allowable tolerances on bomb diameter.

Although these two applications of the theory are of some importance, the leakages concerned are only of order ten per cent. Thus very simple methods are sufficient. There is, however, another field in which more accurate methods are essential for reliable results. This occurs in work on recoilless guns, in which a venturi in the breech discharges gas to counteract the recoil (Fig. A.1). A typical recoilless gun is shown in section in Fig. A.2, which shows also the disc, usually of a thermosetting plastic, which provides the initial seal to the nozzle.

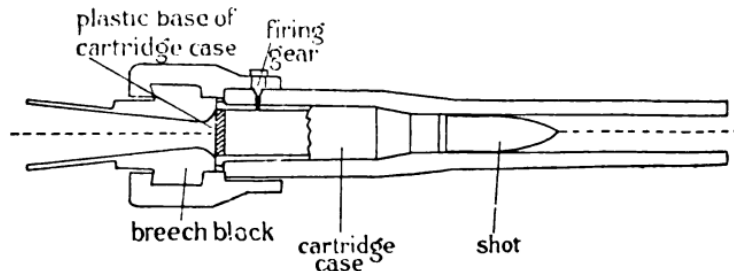

Fig. A.2. A typical recoilless gun in section.

We can approach the idea of this type of recoilless gun in several ways. For example, it may be considered as a rocket and gun built together, with a common cordite chamber. Again, one may think of a "drainpipe," which is obviously recoilless, and which was indeed used as a low-performance gun by Riabouchinsky.† By forming a constriction of suitable form in the pipe we arrive at the form shown in Fig. A.2; this uses less charge than the plain drainpipe and can be made equally recoilless. Finally, we can regard the recoilless gun as a Davis gun in which the counter-projectile thrown to the rear is cordite gas; in this way we reduce the weight of the counter-projectile and eliminate the rear barrel.

The history of this type of recoilless gun appears to begin with the work of Cooke.‡ German experiments began about 1937, and the first production types, the 10.5-cm. and 7.5-cm. L.G.40, were used in the invasion of Crete. Other types built in Germany included the

* Corner, Proc. Roy. Soc., A 188, p. 237 (1947).

† Riabouchinsky, Mem. Artill. Franc. 2 (1923), 689.

‡ Cooke, U.S. patent 1,380,358.

5.5-cm. MK.115 automatic gun for aircraft, and 8.8-cm. guns for light boats and aircraft. The largest was the 28-cm. DKM 44, a coast defence gun firing a shell of 694 lb. at 2450 ft/sec. American interest in recoilless guns dates from 1943*, and details have been published of their 57-mm. and 75-mm. low-pressure recoilless guns.†

In such recoilless guns the leakage is far from being a small correction to be added to the normal ballistic solution. While the charge is burning about half the gas goes out through the nozzle, the other half remaining to increase the pressure in the gun. Thus we must produce a more detailed solution than was adequate for the applications previously mentioned. The theories sketched in this Appendix were in fact studied primarily for their application to recoilless guns.

A.01. Classical theory of nozzles

We begin by stating some useful results from the simplest theory of nozzles. The flow of a *compressible* fluid through a nozzle which first converges and then diverges can be treated very simply by the classical one-dimensional approach. We assume that the state of the medium is a function only of its co-ordinate x , measured parallel to the axis of the nozzle. Further assumptions which are made are that (a) loss of heat to the walls and turbulence and surface friction can be neglected, and (b) the fluid does not separate from the walls. For well-streamlined nozzles (a) gives results which are correct within a few per cent., and the error can therefore be eliminated by using an empirical correction factor which is never far from unity; for such nozzles (b) is also true, at least until the pressure in the gas as it leaves the nozzle falls to approximately the external pressure. This case is of no interest here.

Let $S(x)$ be the cross-sectional area of the channel, with p , ρ , T and v as the values of pressure, density, temperature, and velocity at position x . Let suffix r refer to quantities in the large reservoir where the fluid starts from rest, and suffix t , to conditions at the throat.

We begin with the case of gases obeying the perfect gas laws. As is conventional in internal ballistics, we write R for the gas constant per gram of the gas, and we assume that R and γ are independent of temperature. This is a good approximation in recoilless guns. Finally, we must point out that this treatment applies only to the steady state, though it can be used as an approximation in slowly-varying flows.

There being no accumulation of gas at any section,

$$S\rho v = S_t\rho_t v_t = Q \quad \text{A,01}$$

where Q is a constant.

The expansion of each element of gas being adiabatic,

$$p\rho^{-\gamma} = p_t \rho_t^{-\gamma} = p_r \rho_r^{-\gamma} \quad \text{A,02}$$

From the equation of energy for an element as it passes down the nozzle,

$$(T_r - T) R\gamma/(\gamma - 1) = \frac{1}{2}v^2 \quad \text{A,03}$$

The equation of state is

$$p = \rho RT \quad \text{A,04}$$

At the throat

$$dS/dx = 0$$

* Studler, Army Ordnance, 29 (1945), 232.

† Army Ordnance, September 1945.

so that from A,01

$$\frac{1}{\rho} \frac{d\rho}{dx} + \frac{1}{v} \frac{dv}{dx} = 0 \quad \text{A,05}$$

which leads to

$$T_t/T_r = 2/(\gamma + 1) \quad \text{A,06}$$

and hence the other properties of the gas at the throat are given by

$$p_t/p_r = \{2/(\gamma + 1)\}^{\gamma/(\gamma-1)} \quad \text{A,07}$$

$$\rho_t/\rho_r = \{2/(\gamma + 1)\}^{1/(\gamma-1)} \quad \text{A,08}$$

$$v_t^2 = 2\gamma RT_r/(\gamma + 1) \quad \text{A,09}$$

The rate of flow of mass through the system is

$$Q = \psi \rho_r S_t (RT_r)^{1/2} \quad \text{A,10}$$

$$= \psi p_r S_t (RT_r)^{-1/2} \quad \text{A,11}$$

where

$$\psi = \gamma^{1/2} \{2/(\gamma + 1)\}^{(\gamma+1)/2(\gamma-1)} \quad \text{A,12}$$

when there are no heat or energy losses. In nozzles of good shape ψ lies a few per cent. below the theoretical value. It is to be noted that ψ is nearly independent of γ when this is near 1.25, a typical value for gun propellants. Indeed, ψ lies within one per cent. of 0.66 for the whole range of γ for Service propellants.

These equations are true only if the throat pressure as given by A,07 is greater than the pressure in the space into which the nozzle exhausts.

With a general value of γ , the conditions at any section can easily be calculated. The most useful relations are

$$\left[\frac{p_r}{p}\right]^{2/\gamma} = \frac{2}{\gamma-1} \left[\frac{\gamma+1}{2}\right]^{(\gamma+1)/(\gamma-1)} \left[\frac{S}{S_t}\right]^2 \left[1 - \left(\frac{p}{p_r}\right)^{1-1/\gamma}\right] \quad \text{A,13}$$

which gives the pressure at any expansion-ratio S/S_t , and

$$\left[\frac{T_r}{T}\right]^{2/(\gamma-1)} = \frac{2}{\gamma-1} \left[\frac{\gamma+1}{2}\right]^{(\gamma+1)/(\gamma-1)} \left[\frac{S}{S_t}\right]^2 \left[1 - \frac{T}{T_r}\right] \quad \text{A,14}$$

which gives the temperature at any point. The velocity can be calculated from

$$v^2 = [2\gamma RT_r/(\gamma-1)] [1 - (p/p_r)^{1-1/\gamma}] \quad \text{A,15}$$

Equations A,13, 14 and 15, are true only if p is greater than the external pressure.

A.02. Co-volume corrections

The equations of the preceding section apply only to perfect gases.

Rateau* has obtained the analogous results when the equation of state is

$$p (1/\rho - b) = RT \quad \text{A,16}$$

where b is a co-volume, independent of pressure and temperature. Write

$$\epsilon = b\rho_r/(1 - b\rho_r) \quad \text{A,17}$$

This dimensionless parameter ϵ is a measure of the effect of the co-volume. A reservoir pressure of 25 tons/sq. in. corresponds to $\epsilon = 0.35$, roughly.

The adiabatics of A,16 are

$$p (1/\rho - b)^\gamma = \text{constant} \quad \text{A,18}$$

Rateau has obtained the correction terms for the special case $\gamma = 1.25$. Equation A,06 is replaced by

$$T_t/T_r = [2/(\gamma + 1)] [1 - 0.050 \epsilon + 0.018 \epsilon^2 + 0 (\epsilon^3)] \quad \text{A,19}$$

and A,07 by

$$p_t/p_r = [2/(\gamma + 1)]^{\gamma/(\gamma-1)} [1 - 0.248 \epsilon + 0.117 \epsilon^2 + 0 (\epsilon^3)] \quad \text{A,20}$$

The equation of energy, formerly A,03, is now

$$\frac{1}{2}v^2 = [\gamma R/(\gamma - 1)] [T_r - T] + b [p_r - p] \quad \text{A,21}$$

leading to

$$v_t = [2\gamma RT_r/(\gamma + 1)]^{1/2} [1 + 0.599 \epsilon - 0.128 \epsilon^2 + 0 (\epsilon^3)] \quad \text{A,22}$$

and the rate of flow through the system is

$$Q = \psi p_r S_t (RT_r)^{-1/2} [1 - 0.224 \epsilon + 0.104 \epsilon^2 + 0 (\epsilon^3)] \quad \text{A,23}$$

The highest ϵ reached in normal ballistics is about 0.35, and then the correction terms in A,23 rise to 6½ per cent. Thus the correction can often be neglected, and is always easily included by a slowly-varying factor.

To calculate the thrust from a nozzle it is necessary to find v/v_t , where v is the velocity at the exit section. To terms of order ϵ ,

$$\left[\frac{v}{v_t} \right]^2 = \frac{\gamma + 1}{(\gamma - 1)(1 + 1.2\epsilon)} \left[1 + 0.2\epsilon - \frac{2}{\gamma + 1} \left(\frac{v_t S_t}{v S} \right)^{\gamma-1} \left\{ 1 + (0.281 \frac{v_t S_t}{v S} - 0.206) \epsilon \right\} \right] \quad \text{A, 24}$$

which can be solved numerically by successive approximation.

* Rateau, *Comp. Rend.*, 168 (1919), 330; also *Mem. Artill. Franc.*, 11 (1932), 5.

A.03. The thrust on a nozzle

Let the velocity and pressure at the exit section of area S_e be v_e and p_e respectively. Neglecting atmospheric pressure, the force P on the nozzle is

$$P = Qv_e + S_e p_e \quad \text{A,25}$$

Consider first a channel which converges to a throat, without a diverging part. In this case

$$P = Qv_t + S_t p_t \quad \text{A,26}$$

which from the preceding section reduces to

$$P = [\gamma + 1] [2/(\gamma + 1)]^{\gamma/(\gamma-1)} p_r S_t [1 + 0.097 \epsilon - 0.036 \epsilon^2 + 0 (\epsilon^3)] \quad \text{A,27}$$

where, as usual, the ϵ terms are correct only for $\gamma = 1.25$. The momentum term of A,26 is just γ times the pressure term, apart from the corrections. The factor

$$[\gamma + 1] [2/(\gamma + 1)]^{\gamma/(\gamma-1)}$$

varies from 1.242 to 1.255 as γ changes from 1.2 to 1.3.

Imagine that the throat is gradually widened until it is of the same diameter as the reservoir, until, in fact, the nozzle has become a pipe of uniform cross-section, open at one end and closed at the other. The only thrust on the pipe comes from the pressure on the closed end, and the thrust is therefore $p_r S_t$. This shows that A,27 cannot be used under all conditions. It is certainly correct for a small ratio of throat to reservoir area. When, on the contrary, the throat is no more than a slight constriction, A,27 cannot be used, because the velocity at the throat is not equal to the velocity attained in a proper throat. There does not seem to be any simple treatment of the intermediate case, though it is obvious that A,27 is still an over-estimate when the throat area is greater than 80 per cent. of the area in the main channel before the throat. It is likely that the accuracy of A,27 becomes rapidly greater as the throat area is reduced beyond this value.

Table A.1. Thrust coefficient of a nozzle, $\zeta = P/p_r S_t$

| S_e/S_t | $\gamma = 1.2$ | | $\gamma = 1.3$ | |
|-----------|----------------|------------------|----------------|------------------|
| | $\epsilon = 0$ | $\epsilon = 0.2$ | $\epsilon = 0$ | $\epsilon = 0.2$ |
| 1 | 1.242 | 1.266 | 1.255 | 1.280 |
| 1.2 | 1.318 | 1.355 | 1.327 | 1.336 |
| 1.4 | 1.369 | 1.403 | 1.374 | 1.381 |
| 1.6 | 1.408 | 1.440 | 1.409 | 1.414 |
| 1.8 | 1.439 | 1.470 | 1.438 | 1.440 |
| 2 | 1.466 | 1.494 | 1.461 | 1.462 |
| 2.5 | 1.516 | 1.540 | 1.505 | 1.503 |
| 3 | 1.554 | 1.575 | 1.537 | 1.534 |
| 3.5 | 1.583 | 1.602 | 1.562 | 1.556 |
| 4 | 1.607 | 1.624 | 1.582 | 1.575 |
| 5 | 1.644 | 1.657 | 1.612 | 1.603 |
| 6 | 1.673 | 1.683 | 1.635 | 1.624 |
| 8 | 1.713 | 1.720 | 1.667 | 1.654 |
| 10 | 1.742 | 1.747 | 1.689 | 1.675 |
| ∞ | 2.247 | 2.211 | 1.964 | 1.934 |

When there is a divergent part to the nozzle, the thrust, to terms of order ϵ , is given by the dimensionless *thrust coefficient*

$$\zeta = P/p_r S_t = \gamma [2/(\gamma + 1)]^{\gamma/(\gamma-1)} [v_e/v_t] [1 + 0.375 \epsilon] \\ + [S_t/S_e]^{\gamma-1} [v_t/v_e]^\gamma [2/(\gamma + 1)]^{\gamma/(\gamma-1)} [1 - (1.029 - 0.780 S_t v_t/S_e v_e) \epsilon] \quad \text{A,28}$$

Table A.1 shows the values of ζ for $\gamma = 1.2$ and 1.3 , with $\epsilon = 0$ and 0.2 , and is suitable for linear interpolation over this range of γ and with ϵ between 0 and 0.3 . Although the results are smooth to three decimal places, the last place is intended only to prevent accumulation of rounding-off errors in interpolated values. The real accuracy of the calculations is two decimal places, except that for $\epsilon = 0.3$ the neglect of ϵ^2 terms is likely to cause an error of one or two per cent. The errors of linear interpolation are less than one per cent. Both these and the ϵ^2 errors are less than the deviations between reality and this simple theory.

A.04. The equations of internal ballistics of a leaking gun

We start by deriving a set of equations which are essentially of the same order of accuracy as those given in Section 10.02. We sketch a solution by numerical integration. A simpler solution is then given for the case where the rate of burning is proportional to pressure, having the same order of accuracy as Hunt-Hinds (Chapter VIII). A still simpler method consists in a reduction to an *isothermal* model, which is closely related to Crow's method (Section 9.08). This reduction is particularly useful for grasping the connection between the ballistics of leaking and orthodox guns, and accordingly this method is placed immediately after the most general set of equations have been derived.

ASSUMPTIONS OF THE THEORY

To begin with the assumptions underlying the most accurate set, we may list

- (i) the use of a rate of burning (of the web) βp^α , and
- (ii) the inclusion of a co-volume, independent of the temperature ;
- (iii) bore resistance is neglected, though it is not difficult to include it in the equations ; for the moment we simulate the effect of the resistance by either a shot-start pressure vanishing immediately after engraving, or an equivalent modification of β in the rate of burning.

The following assumptions are associated with the features peculiar to a leaking gun.

- (iv) No unburnt propellant is lost through the nozzle. This is obviously true for smooth-bore guns with a small leakage area between shot and bore, and also for worn orthodox guns. In many types of recoilless guns the cordite is effectively trapped by the cartridge case. Even in the most unfavourable type, guns such as shown in Fig. A.2, the losses of unburnt cordite are small unless the charge burns very slowly. This conclusion is reinforced by a study of the hydrodynamics of the matter.* The assumption may be expected to break down for charges of chopped propellant.
- (v) We assume that the bursting of the disc which initially seals the nozzle and the setting up of the flow through the breech can be represented by the use of the equations for quasi-steady flow through the nozzle, beginning instantaneously at a certain pressure, which we shall call the *nozzle-start* pressure.

The use of this idealisation requires a certain amount of care. For guns with thin discs, such as the paper or sheet brass sometimes used, the breaking of the disc occurs at a time when the rate of increase of pressure is small ; hence in the time taken for the flow to settle down

* Corner and Pack, A.R.D. Theoretical Research Report 27/45 ; AC 9026/ BAL 306.

to steady conditions the pressure in the chamber does not rise much. The nozzle-start pressure is low, and for such guns can often be taken as zero. Thickening the disc delays the initial flow until an epoch where the pressure is rising rapidly, and the nozzle-start pressure under these conditions is considerably greater than that needed to break the disc. The apparent nozzle-start pressure can therefore be expected to show a steep rise once the disc thickness passes a certain value.

One consequence of our assumption of the flow being instantaneously attained is, that if the nozzle-start pressure is zero, then the initial temperature must be slightly less than T_0 , the temperature of uncooled explosion. This is a defect of the assumption, but the errors in the pressure are only a few per cent., and that only during the earliest part of the solution.

In the basic equations and in the more exact of the methods of handling them (Section A.06) it is not assumed that the leakage area is constant during the firing. In most recoilless guns the area is in fact constant. In certain other vented weapons the area does vary; the most obvious example is a worn orthodox gun, in which the leakage area is greatest at the start of the motion of the shot, and decreases rapidly to zero as the projectile moves along. The Germans also tried a recoilless gun in which the nozzle area was varied during the motion, in rough relation to the bore resistance; the idea was to reduce the momentary thrusts on the carriage (*cf.* Section A.11), but the most noticeable effect was erosion of the mechanism.

The more rapid method uses a rate of burning proportional to the pressure, and represents initial resistance by a shot-start pressure.

NOTATION*

This is the same as in the Summary (p. 214), except for the following new symbols. Let the mass of gas present in the gun at time t be CN . The equation of state of the products of uncooled explosion of the propellant is

$$p(1/\rho - b) = F \quad \text{A,29}$$

The burning law is

$$Ddf/dt = -\beta p^\alpha \quad \text{A,30}$$

with

$$z = (1 - f)(1 + \theta f) \quad \text{A,31}$$

PRESSURE AND DENSITY DISTRIBUTION INSIDE THE GUN

The conventional theory of the distribution inside an orthodox gun assumes that the density of gas is independent of position in the gun. Results of this theory are that†

$$\text{the space-mean pressure} = p(1 + C/3W)/(1 + C/2W) \quad \text{A,32}$$

where p is the pressure at the breech, and

$$\text{the pressure at the shot} = p/(1 + C/2W) \quad \text{A,33}$$

For a gun with leakage there must be some allowance for the fact that the mass of gas in the gun never attains C . Moreover, the velocity field of the gas is altered if leakage takes place backwards through the breech. To cover these diverse possibilities, we may consider replacing C in A,32 and A,33 by $kC(N + 1 - z)$, where the numerical factor k will be unity for forward leakage and will be reduced if the leakage is backwards. It is also possible to use, instead of $kC(N + 1 - z)$, the alternative expression kCN , which corresponds to replacing C in A, 32 and A,33 by Cz , for orthodox guns. The form kCN is easier in application, and its use alters muzzle velocity and peak pressure by only one or two per cent. at velocities up to 2000 f/s.

* Throughout this Appendix consistent units are assumed; for conversion to practical units see p. 98.

† Section 7.07; equation 7,18.

We use, therefore,

$$\text{space-mean pressure} = p/(1 + kCN/6W) \quad \text{A,34}$$

$$\text{pressure at shot} = p/(1 + kCN/2W) \quad \text{A,35}$$

We assume that the gas density is ρ everywhere along the gun at the instant considered. Then

$$\rho [K_0 + Ax - C(1 - z)/\delta] = CN \quad \text{A,36}$$

Let $T^\circ K.$ be the mean temperature of the gases at the moment considered. We have from A,34

$$p(1/\rho - b) = RT(1 + kCN/6W)$$

which with A,36 becomes

$$p [K_0 + Ax - C(1 - z)/\delta - CNb] = CNRT(1 + kCN/6W) \quad \text{A,37}$$

Numerical examples have shown that for guns with a substantial leak, such as recoilless guns, this equation may usually be replaced by

$$p [K_0 + Ax - C/\delta] = CNRT(1 + kCN/6W) \quad \text{A,38}$$

with ample accuracy, right up to the time when the charge is all burnt. In a typical case the error in the pressure due to using A,38 was at most $\frac{1}{2}$ per cent., which occurred in the early stages; the error decreased with time until $z = 1$, and was 0.3 per cent. when $z = \frac{1}{2}$. This is about a tenth of the corresponding error in an orthodox gun at the same stage of burning.

In exceptional cases errors of as much as 10 per cent. have been found. It has been noted that for a given gun and shot these percentage errors are almost independent of the loading and initial conditions, and are substantially constant over the important period of high pressure during the firing. These remarks justify the following correction: we use A,38 always, and on the first calculation with a new type of gun we find the percentage error at maximum pressure due to the use of A,38 instead of A,37. If this error is appreciable we correct all future runs by this factor. In the exact method it is necessary only to multiply $CNRT$ by the appropriate factor to get the corrected pressure. In our approximate method (Section A.07) we absorb the correction into F , using the corrected value, F_1 , say, to replace F only in equations A,71, 84, 85, 90 and 91.

Where the leakage is small, as in smooth-bore guns and worn guns, the approximation A,38 is as inaccurate as in orthodox internal ballistics. After $z = 1$, the approximation becomes inadequate in all cases, and in this part of the solution we use the exact equation A,37.

The equation of motion of the shot is

$$W_1 d^2x/dt^2 = Ap \quad \text{A,39}$$

where W_1 is a modified shot mass, which from A, 35 is equal to

$$W_1 = W + \frac{1}{2} kCN \quad \text{A,40}$$

Corrections for recoil, rotational inertia and bore-resistance are included in W .*

* Section 7.01.

NOZZLE FLOW AND ENERGY RELATIONS

It has been shown that the rate of flow through the nozzle is

$$Q = \psi p_r S_r (RT_r)^{-1/2} \quad \text{A,41}$$

where p_r and T_r refer to the reservoir conditions, and ψ is a numerical factor which would be 0.66 if there were no heat or energy losses, and which lies a few per cent. lower for leakage channels of good shape. Co-volume corrections reduce the flow slightly, by about $6\frac{1}{2}$ per cent. at pressures of 25 tons/sq. in., and thus may be neglected. Their mean effect can be taken into account by a slight change in ψ between high and low pressure firings in the same gun. We may now identify p_r with p and T_r with T , the latter introducing a relative error in Q of order $kCN/30W$. Hence

$$CdN/dt = Cdz/dt - \psi Sp (RT)^{-1/2} \quad \text{A,42}$$

We come now to the equation of energy. In time dt the gas gives kinetic energy $Apdx$ to the shot and the gas in front of the stagnation point; a mass Cdz is evolved from the cordite, and $C(dz - dN)$ passes out through the nozzle. We treat this process in three steps.

(i) The gas, of internal energy $CNE(T)$, provides kinetic energy $Apdx$; in this stage the temperature changes by

$$dT = - (Ap/CN\sigma_v) dx \quad \text{A,43}$$

where σ_v is the specific heat (at constant volume) of the gases, at temperature T ; since $\sigma_v = R/(\gamma - 1)$, A,43 can be written as

$$CNRdT = - (\gamma - 1) Apdx \quad \text{A,44}$$

(ii) A mass Cdz , with internal energy $E(T_0)Cdz$ enters the gas; hence

$$CE(T_0)dz = CN\sigma_v dT + CE(T) dz$$

and so

$$NdT = (T_0 - T) dz \quad \text{A,45}$$

if σ_v is constant over the range T to T_0 .

(iii) A mass $C(dz - dN)$ escapes through the nozzle. Since the expansion is adiabatic, we have

$$\frac{dT}{T} = \frac{\gamma - 1}{1/\rho - b} \frac{d\rho}{\rho^2}$$

Also
Hence

$$d\rho/\rho = (dN - dz)/N$$

$$dT/T = (\gamma - 1) (1 + \epsilon) (dN - dz)/N \quad \text{A,46}$$

using A,17.

Summing all three effects,

$$N \frac{dT}{dt} = -(\gamma - 1) \frac{Ap}{CR} \frac{dx}{dt} + (T_0 - T) \frac{dz}{dt} + (\gamma - 1) (1 + \epsilon) T \left(\frac{dN}{dt} - \frac{dz}{dt} \right)$$

and so

$$\frac{dNT}{dt} = -(\gamma - 1) \frac{Ap}{CR} \frac{dx}{dt} + T_0 \frac{dz}{dt} + \{ \gamma + (\gamma - 1) \epsilon \} T \left\{ \frac{dN}{dt} - \frac{dz}{dt} \right\}$$

and using A,42

$$\frac{dNT}{dt} = -(\gamma - 1) \frac{Ap}{CR} \frac{dx}{dt} + T_0 \frac{dz}{dt} - \{\gamma + (\gamma - 1)\epsilon\} \frac{\psi Sp (RT)^{\dagger}}{CR} \quad \text{A,47}$$

The term in ϵ can be omitted with a relative error of 7 per cent. at $\epsilon = 0.35$, which is almost exactly compensated by the error in using a constant ψ throughout a solution.

SUMMARY OF THE EQUATIONS

With nozzle open, shot in motion, and charge not completely burnt, we have

$$(A,38) \quad p (K_0 + Ax - C/\delta) = CNRT (1 + kCN/6W) \quad \text{A,48(a)}$$

$$(A,39) \quad W_1 d^2x/dt^2 = Ap \quad \text{A,48(b)}$$

$$(A,40) \quad W_1 = W + \frac{1}{2} kCN \quad \text{A,48(c)}$$

$$(A,30) \quad Ddf/dt = -\beta p^z \quad \text{A,48(d)}$$

$$(A,31) \quad z = (1 - f) (1 + \theta f) \quad \text{A,48(e)}$$

$$(A,42) \quad dN/dt = dz/dt - \psi Sp/C (RT)^{\dagger} \quad \text{A,48(f)}$$

$$(A,47) \quad \frac{dNT}{dt} = -(\gamma - 1) \frac{Ap}{CR} \frac{dx}{dt} + T_0 \frac{dz}{dt} - \frac{\gamma \psi Sp (RT)^{\dagger}}{CR} \quad \text{A,48(g)}$$

Various special cases arise : before the nozzle opens, $S = 0$; before the shot starts, $x = 0$; after all-burnt, $z = 1$, and A,38 is replaced by

$$p (K_0 + Ax - CNb) = CNRT (1 + kCN/6W) \quad \text{A,49}$$

A.05. The equivalent non-leaking ballistic problem

In this section we shall consider a simplified version of the set of equations A,48, and by comparison with the analogous equations for an orthodox gun we shall show the nature of the effects produced by gas leakage. The level of approximation is essentially that of Crow's method.*

We assume that there is no initial resistance to motion of the shot, and that the nozzle flow is established at a low pressure. In practical applications it is possible to make partial correction for these approximations by altering the rate of burning. It is assumed also that the rate of burning is proportional to pressure and that the leakage area S is constant.

Putting $S = 0$ in A,48, we return to the equations of an orthodox gun. The variation of the gas temperature with time is decided by the competition between the two terms remaining on the right of A,47 : the first term represents the lowering of the energy of the gas by the work done on the shot ; the second term corresponds to the increase of energy by the burning of the propellant. The competition between these terms leads to a temperature which falls only slowly from the initial value T_0 , though the decrease becomes rather more marked towards the end of burning ; after the cordite has been consumed there is of course a further drop of temperature during the adiabatic expansion of the gases.

* Section 9.08.

When there is a constant leakage area S , there is an additional term on the right of A,47, tending to lower the temperature because of the work done in pushing gas out of the nozzle. The effect on the temperature-time curve depends mainly on the ratio S/A , where A is the bore cross-section. For recoilless guns with nozzles of reasonably good shape, S/A lies near 0.65, and in such cases the temperature shows a rapid drop after the nozzle opens, thereafter flattens out, and later shows the increasing rate of decline characteristic of ordinary guns. For most of the period of burning the gas temperature in the recoilless gun is about 90 per cent. of the temperature at the corresponding period in an orthodox gun.

We approximate to both leaking and orthodox guns by isothermal equations, in which the gas temperature is given a mean value during the burning. For a normal gun this mean should be about $0.9 T_0$ if co-volume terms are included in the equations, while if it is assumed that $b = 1/\delta$ then the appropriate mean temperature rises with peak pressure, to about T_0 at 20 tons/sq. in. The mean to be used with leakage is mainly a function of S/A , decreasing to about $0.85 T_0$ at $S/A = 0.7$. Thus one effect of leakage is to reduce the effective force-constant of the propellant by an amount of order ten per cent.

We write the mean value of RT as λ . Then by integrating and using $\alpha = 1$, we arrive at

$$p (K_0 + Ax - C/\delta) = \lambda C (1 - f) (1 - \Psi + \theta f) \quad \text{A,50}$$

after omitting the factor $(1 + kCN/6W)$ from the right-hand side, as this factor is never far from unity. The dimensionless parameter

$$\Psi = \psi SD/\beta C\sqrt{\lambda} \quad \text{A,51}$$

is, as it will appear, the fundamental quantity expressing the effect of leakage on the internal ballistics. In practice Ψ is of order 0.1 for smooth-bore and eroded guns and of order 0.5 for fully recoilless guns.

A,50 may be written as

$$p (K_0 + Ax - C/\delta) = \lambda C (1 - \Psi) (1 - f) (1 + \theta' f) \quad \text{A,52}$$

where

$$\theta' = \theta/(1 - \Psi) \quad \text{A,53}$$

An orthodox gun with a charge $C(1 - \Psi)$ of cordite with mean force λ and form-factor θ' , would have the equation

$$p [K_0 + Ax - C(1 - \Psi)/\delta] = \lambda C (1 - \Psi) (1 - f) (1 + \theta' f) \quad \text{A,54}$$

which differs from A,52 in a term which is important only at high densities of loading. Indeed the term $C(1 - \Psi)/\delta$ is correct only at the start of motion, later increasing to $C(1 - \Psi)b$, which is 60 per cent. greater. Thus up to all-burnt the leaking gun behaves almost as if it were an orthodox gun with the *same* dimensions, the smaller charge $C(1 - \Psi)$, the bigger form-factor $\theta' = \theta/(1 - \Psi)$, and a force-constant reduced as described earlier.

Since θ' is numerically greater than θ , it follows that a shape which is degressive in an ordinary gun is even more so in a recoilless gun.

It is also possible to approximate to the leaking gun by a normal gun with the same charge C , form-factor $\theta/(1 - \Psi)$, and smaller force-constant $\lambda(1 - \Psi)$. This is not a great deal of help in visualising the behaviour of recoilless guns, since the change of force-constant required is outside the experience of the ballisticians, unless he is familiar with gunpowder charges. For guns with small leakage the analogy is useful.

The *effective charge*

$$C' = C(1 - \Psi) = C - \psi SD/B\lambda^\dagger \quad \text{A,55}$$

which may be written in a form which brings out the significance of the terms. From A,30 and A,39,

$$AD(1 - f) = \beta \bar{W}_1 v \quad \text{A,56}$$

and if v_2 is the velocity at all-burnt,

$$AD = \beta \bar{W}_1 v_2$$

For a typical gun, v_2 is about 80-90 per cent. of the muzzle velocity v_3 , so that we can use

$$AD = 0.85 \beta \bar{W}_1 v_3 \quad \text{A,57}$$

For an orthodox gun with expansion-ratio about 5, the energy of the shot at the muzzle is

$$\frac{1}{2} W_1 v_3^2 \simeq C' RT_0/3 (\gamma - 1) \simeq 4C'\lambda/3 \quad \text{A,58}$$

Substituting from A,57 and A,58 in A,55,

$$C \simeq 3W_1 v_3^2/8\lambda + 0.85 \psi \bar{S} \bar{W}_1 v_3/A\lambda^\dagger$$

These terms may be regarded as the *part that pushes* and the *part that leaks*, respectively. For a recoilless gun, $S/A \simeq 0.65$ and $\psi \simeq 0.63$, giving

$$C \simeq 3W_1 v_3^2/8\lambda + 0.35 \bar{W}_1 v_3/\lambda^\dagger \quad \text{A,59}$$

The second term on the right may be regarded as the charge thrown backwards to balance the momentum of the shot.

A formula of type A,59 was used by certain German engineers for the design of recoilless guns, and was based on the argument that part of the charge pushes and the rest balances the recoil. They took the coefficient of $W_1 v_3^2/\lambda$ to be rather greater than 3/8, and the coefficient of the other term was determined by fitting to firings with reasonable charges. This process is obviously not exact, though it does give a guide sufficient for preliminary design. The reduction to an orthodox gun holds, it will be noticed, only up to all-burnt. After that time the pressure-space curve shows a much more rapid drop than in the equivalent orthodox gun; this will be shown in Section A.08. It is clear that for this reason the coefficient 3/8 ought to be increased, as was indeed done by the Germans. Another factor which makes it necessary to increase this term, when dealing with recoilless guns, is that as the charge is larger than normal the expansion-ratio tends to be smaller than usual, and the muzzle energy per unit of effective charge C is therefore lower than in most normal guns.

A formula which is fairly satisfactory up to 2000 f/s. is

$$C/W = \frac{1}{2} y (y + 0.87) \quad \text{A,60}$$

where

$$y = v_3/\Gamma^\dagger$$

Strecke* has constructed a theory based on the assumptions used in our reduction to an orthodox gun : mean gas temperature, $\alpha = 1$, effective co-volume equal to the initial volume of the charge, and nozzle opening at the instant that the shot starts. His work is more general in that he uses a shot-start pressure to represent initial resistance, and more special in that he considers only $\theta = 0$. Since he uses the balance of momentum during firing, his method is applicable only to fully recoilless guns, whereas the present methods can be used whatever the extent of the leakage.

In an orthodox gun the muzzle velocity is, for small changes in the charge weight, proportional to the charge to a power n , where n is usually about 0.7. When there is leakage the effective charge is $C(1 - \Psi)$. Hence the effect of a small leakage when the charge or web-size is not altered is that the muzzle velocity varies directly as

$$(1 - \Psi)^n \simeq 1 - n\Psi \quad \text{A,61}$$

in which n is certainly non-zero. The inefficiency of a leaking gun after all-burnt causes n to be rather larger than for the orthodox gun with the same *effective* charge.

For propellants with θ nearly zero, and not too small a web, the maximum pressure is proportional to the square of the charge ; hence peak pressure varies directly as

$$(1 - \Psi)^2 \simeq 1 - 2\Psi \quad \text{A,62}$$

Exceptions are charges of cord, and fast charges in which the peak pressure occurs at all-burnt. These can be treated by the same methods, though the final formulae are rather different.

The central ballistic parameter $M\ddagger$ varies directly as

$$1 + \Psi \quad \text{A,63}$$

These ballistic quantities are thus all linear in Ψ .

When we consider small changes in a large Ψ , we find that such quantities as $(dv_3/d\Psi)/v_3$ have a factor $(1 - \Psi)$ in their denominators. It follows that recoilless guns, where Ψ is of order 0.5, are more than normally sensitive to changes of web or rate of burning. A factor which enters in all low-pressure guns is the unusually big influence of engraving conditions, since the ratio of engraving pressure to peak pressure is exceptionally large. Low-pressure recoilless guns are a difficult problem for the ballisticians.

A.06. Numerical integration

The set of equations A,48 can always be integrated numerically in a straightforward way. It is convenient to write these equations in terms of non-dimensional variables. We write

$$x = x_0\xi \quad \text{with } x_0 = K_0/A \quad \text{A,64 (a)}$$

$$S = \mu A \quad \text{A,64 (b)}$$

$$t = x_0 F^{-1} \tau \quad \text{A,64 (c)}$$

$$T = T_0 T' \quad \text{A,64 (d)}$$

$$p = (CF/K_0) \Pi \quad \text{A,64 (e)}$$

$$v = F^{\ddagger} d\xi/d\tau \quad \text{A,64 (f)}$$

* Strecke, DWM-FMB No. 13.

† See equation 8,08.

The set A,48 becomes

$$(1 + \xi - C/K_0\delta) \Pi = NT' (1 + kCN/6W) \quad \text{A,65 (a)}$$

$$d^2\xi/d\tau^2 = C\Pi/W_1 \quad \text{A,65 (b)}$$

$$W_1 = W + \frac{1}{2}kCN \quad \text{A,65 (c)}$$

$$df/dt = -(\beta K_0/DAF^\dagger) (\Pi CF/K_0)^\alpha \quad \text{A,65 (d)}$$

$$z = (1 - f) (1 + \theta f) \quad \text{A,65 (e)}$$

$$dN/d\tau = dz/d\tau - \mu\psi\Pi (T')^{-\dagger} \quad \text{A,65 (f)}$$

$$d(NT')/d\tau = -(\gamma - 1) \Pi d\xi/d\tau + dz/d\tau - \gamma\mu\psi\Pi(T')^\dagger \quad \text{A,65 (g)}$$

After all-burnt,

$$(1 + \xi - CNb/K_0)\Pi = NT' (1 + kCN/6W) \quad \text{A,66}$$

These variables increase the generality of each computed solution. They are also useful in deriving relations of similarity.

The equations can be solved by a step-by-step integration proceeding in steps of equal $\Delta\tau$. The method is straightforward. It is possible to reduce the labour of computation by the following approximations : using Δ to denote increments over a step of the integration, and bars to denote mean values over the step,

$$\Delta N = \Delta z - \mu\bar{\psi} (\bar{T}')^{-\dagger} \Delta (f \Pi d\tau) \quad \text{A,67}$$

$$\Delta (NT') = -[(\gamma - 1) \bar{W}_1/2C] \Delta (d\bar{\xi}/d\tau)^2 + \Delta z - \gamma\mu\bar{\psi} (\bar{T}')^\dagger \Delta (f \Pi d\tau) \quad \text{A,68}$$

Since $(T')^\dagger$ and \bar{W}_1 vary only slowly, it is possible to use the same average values for several steps in succession.

Numerical integration is suitable when the nozzle throat area S is varying during the firing, or when bore resistance has to be taken into account ; an example where both points arise is the treatment of a worn gun (Section A.10). The set of equations A,65 is easily modified to include bore-resistance terms. Numerical integration seems to be necessary also when α , the pressure-index of the rate of burning, differs substantially from unity.

Numerical integration can be carried out no matter how one may choose to represent initial resistance. The integration need not be carried past all-burnt. An analytical solution of ample accuracy is available for the period after all-burnt and will be explained in Section A.08.

A.07. Solution with linear rate of burning

A more rapid method than numerical integration can be used if $\alpha = 1$. This has been built up in a semi-empirical manner by a study of a large number of numerical integrations, and offers a considerable saving of time. We assume that the throat area S is independent of time, and the initial conditions are represented by nozzle-start and short-start pressures. We denote conditions at these epochs by suffixes $_s$ and $_o$.

We shall work in ordinary units except that the temperature T will be written as $T_o T'$.

The equations of the system are

$$Ddf/dt = -\beta p \quad \text{A,69}$$

$$z = (1-f)(1+\theta f) \quad \text{A,70}$$

$$p(K_0 + Ax - C/\delta) = CNFT'(1 + kCN/6W) \quad \text{A,71}$$

$$W_1 v dv/dx = Ap \quad \text{A,72}$$

$$W_1 = W + \frac{1}{2}kCN \quad \text{A,73}$$

$$dN/dt = dz/dt - \psi Sp/C (FT')^\dagger \quad \text{A,74}$$

$$\frac{dNT'}{dt} = -\frac{\gamma-1}{2CF} \frac{dW_1 v^2}{dt} + \frac{dz}{dt} - \frac{\gamma\psi Sp}{C(F/T')^\dagger} \quad \text{A,75}$$

Eliminating p from A,69 and A,74 and integrating,

$$N = z + \psi SD (f - f_N)/\beta CF^\dagger v_1 \quad \text{A,76}$$

where

$$\frac{1}{v_1} = \frac{1}{f - f_N} \int_{f_N}^f (T')^{-\dagger} df \quad \text{A,77}$$

It is convenient to write, as in Section A.05,

$$\Psi = \psi SD/\beta CF^\dagger \quad \text{A,78}$$

Then A,76 becomes

$$N = z - \Psi (f_N - f)/v_1 \quad \text{A,79}$$

Inspection of a number of accurate solutions has shown that it is sufficiently accurate to take

$$v_1 = \frac{1}{4}(1 + 3\sqrt{T'}) \quad \text{A,80}$$

From A,69 and A,72,

$$v = AD (f_0 - f)/\beta \bar{W}_1 \quad \text{A,81}$$

This holds from shot-start to all-burnt. It is sufficient to take for \bar{W}_1 over any interval the mean of the values of W_1 at the ends of the interval.

From A,69 and A,75,

$$NT' = (NT')_N + z - z_N - \frac{1}{2}(\gamma-1) W_1 v^2/CF + \gamma\Psi (f - f_N) v_2 \quad \text{A,82}$$

where

$$v_2 = \frac{1}{f - f_N} \int_{f_N}^f (T')^\dagger df$$

Since $N = z$ at nozzle-start, and T_N' is accurately unity if $p_N \leq p_0$ and never far from unity under any conditions,

$$NT' = z - \frac{1}{2}(\gamma-1) W_1 v^2/CF + \gamma\Psi (f - f_N) v_2$$

which with A,79 reduces to

$$T' [z + (\gamma - 1) \Psi (f_N - f)/v_3] = z - \frac{1}{2} (\gamma - 1) W_1 v^2 / CF \quad A,83$$

where

$$(\gamma - 1)/v_3 = \gamma v_2 / T' - 1/v_1$$

Equation A,83 holds after the opening of the nozzle. If the shot starts first, A,83 is used, until the nozzle opens, with $\Psi = 0$.

We need also a relation between the shot-travel and the fraction of charge burnt. Eliminating p and v from A,71, 72 and 81, and integrating,

$$\int \frac{A dx}{K_0 + Ax - C/\delta} = -\frac{M}{v_4} \int \frac{(f_0 - f) df}{N} \quad A,84$$

where M is practically $(AD/\beta)^2/FCW_1$, the ballistic parameter for orthodox guns (equation 8,08) and v_4 is a mean value of T' .

This result is true whether shot-start occurs before or after the opening of the nozzle. We must now, however, distinguish between these two cases.

CASE A : $p_N \leq p_0$

In this case N is given by A,79 for the whole of the period of motion of the shot. Substituting into A,84 and integrating from shot-start onwards,

$$\ln [1 + Ax/(K_0 - C/\delta)] = MI/v_4 \quad A,85$$

where

$$I = \int_f^{f_0} \frac{(f_0 - f) df}{z - \Psi (f_N - f)/v_1}$$

In the integrand v_1 is a function of T' , and to make progress one must average v_1 . We find that, writing the average value of Ψ/v_1 as Ω , for $\theta \neq 0$

$$I = \frac{1}{2\theta} \ln \frac{\Phi(f_0)}{\Phi(f)} - \frac{\Theta(f_0)}{\theta} \left[\tanh^{-1} \Theta(f) - \tanh^{-1} \Theta(f_0) \right] \quad A,86$$

where

$$\Phi(f) = 1 - \Omega f_N + (\theta + \Omega - 1)f - \theta f^2$$

$$\Theta(f) = [2\theta f - \theta - \Omega + 1] [4\theta (1 - \Omega f_N) + (\theta + \Omega - 1)^2]^{-1/2}$$

This is true only if $\Theta(f)$ and $\Theta(f_0)$ are less than unity. If either is greater than unity, the corresponding \tanh^{-1} should be replaced by \coth^{-1} .

For $\theta = 0$,

$$I = \frac{f_0 - f}{1 - \Omega} - \frac{\Phi'(f_0)}{(1 - \Omega)^2} \ln \frac{\Phi'(f)}{\Phi'(f_0)} \quad A,87$$

where

$$\Phi'(f) = 1 - \Omega f_N + (\Omega - 1)f$$

i.e. $\Phi(f)$ with $\theta = 0$.

We have found that pressures correct to a few per cent. can be obtained by taking

$$1 - v_4 = 50(1 - T')^2(T' - 0.78)/[1 + 2.5(1 - T')] \quad \text{A,88}$$

$$\Omega = 2\Psi/(3\sqrt{T' - 1}) \quad \text{A,89}$$

The fact that v_4 is greater than unity for T' less than 0.78 is due to Ω being least accurate in this region. The pair of formulae, A,88 and A,89, have been chosen to compensate for each other's deficiencies even at these low temperatures. The integral I becomes infinite for $\Omega = 1$ and correspondingly sensitive to Ω if Ω is near unity. This approximate method is unreliable for Ω greater than 0.8. In such cases the pressure-space curve is very flat and it is better to integrate A,72 in large steps, using A,81 and mean values of p ; one finds x thereby, and hence p from A,71, correcting the integration if necessary. This is much simpler than carrying out the numerical integration of the full set of equations, though the process is of course restricted to flattish pressure-space curves. The process was suggested by Mr. T. Vickers.

CASE B : $p_N > p_0$

Before the opening of the nozzle $N = z$, and so

$$\ln [1 + Ax/(K_0 - C/\delta)] = (M/v_4) I \quad (\Omega = 0) \quad \text{A,90}$$

After nozzle-opening N is taken from A,79 and

$$\ln \frac{K_0 - C/\delta + Ax}{K_0 - C/\delta + Ax_N} = \frac{MJ}{v_4} \quad \text{A,91}$$

where

$$J = \int_f^{f_N} \frac{(f_0 - f)df}{z - \Psi(f_N - f)/v_1}$$

This integral can be evaluated :

for $\theta \neq 0$,

$$J = \frac{1}{2\theta} \ln \frac{\Phi(f_N)}{\Phi(f)} - \frac{\Theta(f_0)}{\theta} \left[\tanh^{-1} \Theta(f) - \tanh^{-1} \Theta(f_N) \right] \quad \text{A,92}$$

and for $\theta = 0$,

$$J = \frac{f_N - f}{1 - \Omega} - \frac{\Phi'(f_0)}{(1 - \Omega)^2} \ln \frac{\Phi'(f)}{\Phi'(f_N)} \quad \text{A,93}$$

with the usual caution about the replacement of \tanh^{-1} by \coth^{-1} if the argument is greater than unity.

We give now a summary of the use of these equations. We have introduced various mean values such as Ω and the v 's, and we shall give rules for their estimation. These were derived by analysis of a number of accurate solutions for various initial conditions, and it is not suggested that they are the only rules which will work. However, these formulae are simple, and our experience has shown that pressures, velocities and shot-travels can be computed in this way to within two or three per cent. This is sufficiently accurate for routine ballistic calculations, being usually less than the error arising from uncertainties in the nozzle-start and shot-start pressures.

CASE A : $p_N \leq p_0$

Solution at nozzle-start

Equation A,71 with $p = p_N$, $T' = 1$ and $x = 0$ gives $N_N = z_N$. From A,70 we derive f_N .

Solution at shot-start

We guess T'_0 . A,71 with $p = p_0$ and $x = 0$ gives N_0 . Calculating v_1 from A,80, z_0 and f_0 follow from A,70 and A,79. We take, *in this part of the computation*,

$$v_3 = 1 - 6(1 - T') / \{2 + 10^3(1 - T')^3\} \quad \text{A,94}$$

and obtain T'_0 from A,83 with $v = 0$. The process is now repeated until a self-consistent set of values is reached.

Solution for any desired f less than f_0

We guess T' at this value of f . In succession we obtain v_1 from A,80, z from A,70, N from A,79 and v from A,81. We estimate v_3 here as

$$v_3 = 1.75T' - 0.75 \quad \text{A,95}$$

and then T' can be calculated from A,83. We repeat until the results are self-consistent.

To calculate the corresponding shot-travel we use A,88, 89 and 85, with either A,86 or 87. The pressure can now be calculated from A,71.

Maximum pressure

By calculating the pressure at three or four evenly-spaced values of f , the maximum pressure can be found by interpolation.

CASE B : $p_N > p_0$

Solution at shot-start

Equation A,71 with $p = p_0$, $x = 0$ and $T' = 1$ gives $z_0 = N_0$, and f_0 follows from A,70.

Solution at nozzle-start

We guess f_N , obtaining v from A,81, $z = N$ from A,70, T' from A,83 with $\Psi = 0$, and x from A,90 with v_4 from A,88. The pressure can now be calculated from A,71. We repeat with other values of f and interpolate for $p = p_N$.

Solution after nozzle-start

The only difference from the procedure in case A is that A,92 and A,93 replace A,86 and A,87.

A.08. Solution after all-burnt

This is so much simpler than the problem during burning that an approximate analytical solution can be derived by modifying the method used for the same period in the orthodox gun.

From the exact equations, in reduced units, we have, neglecting $kCN/6W$,

$$\frac{d(NT')}{NT'} = - \frac{Hd\xi}{1 + \xi - bCN/K_0} \quad \text{A,96}$$

where

$$H = \gamma - 1 + \gamma\mu\psi(T')^\dagger / (d\xi/d\tau) \quad \text{A,97}$$

Let suffix ₂ denote conditions at all-burnt. We can integrate A,96 by taking mean values of H and N, giving

$$\log \frac{NT'}{(NT')_2} = \bar{H} \log \frac{1 + \xi_2 - bC\bar{N}/K_0}{1 + \xi - bC\bar{N}/K_0} \quad \text{A,98}$$

We can write A,96 in the alternative form

$$\frac{dNT'}{d\tau} = -H\Pi \frac{d\xi}{d\tau} = -\frac{HW_1}{C} \frac{d\xi}{d\tau} \frac{d^2\xi}{d\tau^2}$$

leading to

$$(d\xi/d\tau)^2 - (d\xi/d\tau)_2^2 = 2C\{(NT')_2 - NT'\}/\bar{H}\bar{W}_1 \quad \text{A,99}$$

Finally,

$$N_2 - N = \mu\psi \int \Pi(T')^{-1} d\tau = \mu\psi (\bar{T}')^{-1} \{d\xi/d\tau - (d\xi/d\tau)_2\} \quad \text{A,100}$$

From these equations can be calculated close approximations to the conditions at any desired travel after all-burnt, and in particular the muzzle velocity is easily derived. The detailed working runs thus. We know ξ_2 , T_2' , $(d\xi/d\tau)_2$ and N_2 , from which we compute H_2 . We guess $(T')^{-1}$, $d\xi/d\tau$ and N at the assigned value of ξ ; H follows from A,97, and we take

$$\bar{H} = \frac{1}{2} (H_2 + H)$$

$$\bar{N} = \frac{1}{2} (N_2 + N)$$

then obtaining NT' from A,98. We calculate \bar{W}_1 from \bar{N} , and then find $d\xi/d\tau$ from A,99. Finally N is obtained from A,100, using the mean value

$$(\bar{T}')^{-1} = \frac{1}{2} [(T_2')^{-1} + (T')^{-1}]$$

The cycle is repeated until self-consistent. The number of cycles necessary depends on the success of the first guess but is normally of order two.

Errors in $d\xi/d\tau$, N and T' in a typical calculation of this type for a fully recoilless gun were found to be 0.2, -4 and -16 per cent., respectively, of the change from all-burnt to shot-ejection, i.e., about 0.1, -2 and -5 per cent., respectively, of the values at ejection. The error in muzzle velocity is only a few feet per second, which is usually a trivial price to pay for the reduction of computation effected by this method.

The shape of the pressure-space curve during the adiabatic expansion, which in ordinary guns is determined by $\gamma - 1$, is settled here by the quantity \bar{H} . For a typical recoilless gun \bar{H} is of order 2, whereas $\gamma - 1$ is only about 0.3; hence after all-burnt the pressure-space curve falls much more rapidly than in an orthodox gun.

The process of successive approximations given above fails to converge if the expansion goes so far that almost all the gas passes through the vent before the shot reaches the muzzle. In such cases the change in H from all-burnt to ejection is so large that it is not possible to reach the muzzle in one step of computation. There is no reason, however, why one should not divide the process into several steps, each taking as its initial conditions the final results of the previous step. While expansion down to almost zero pressure and temperature is an inefficient way of using a gun, it does occur in practice in low-velocity rounds from a recoilless howitzer, such as that shown in Fig. A.1. When such a gun, giving about 1000 f/s. at top charge,

is fired at a velocity of order 400 f/s., we have the following circumstances : to be sure of starting the shot, the peak pressure must be of order 4 tons/sq. in. ; therefore, to keep down the muzzle velocity to 400 f/s. the charge must burn out very rapidly ; hence there is a long travel after all-burnt, during which T' falls greatly ; because $d\xi/d\tau$ is small, H is large at all-burnt ; because $(T')^\dagger$ is small when the shot reaches the muzzle, H is then small ; hence this is a case where H varies greatly between all-burnt and ejection, and this interval must be broken into two or three steps. Of course the muzzle velocity can in such cases be estimated from A,99 with $NT' = 0$, provided again that one can estimate \bar{H} . If the gain in energy of the shot after all-burnt is sufficiently small the uncertainty in \bar{H} will lead to an uncertainty in the muzzle velocity which is adequate for many purposes. It should be remembered that such low-velocity results are very sensitive to the initial conditions assumed in the calculations, so that analysis of such firings is at best a tricky business.

The formulae of this section are useful when it is proposed to vent the gun near the muzzle. This has been suggested, from time to time, as a cure for various difficulties. The effect on muzzle velocity can be found by the formulae given above, taking the initial conditions to be those computed by orthodox ballistics for the shot-position at which venting starts. Questions involving the smooth-bore muzzle-extension can be treated in the same way.

A.09. Gas leakage in a smooth-bore mortar

To study this problem it is desirable to start by combining all mortars in a general formula. The loss of muzzle velocity Δv_3 due to a leakage area S , constant during travel of the bomb, is given by A,61 as

$$\Delta v_3/v_3 = -n\Psi = -n\psi SD/\beta C\lambda^\dagger \quad \text{A,101}$$

where n varies somewhat with the details of gun and charge, but is usually around 0.7. Furthermore,

$$AD = m\beta Wv_3$$

with m around 0.8—0.9. Also

$$C = q(\gamma - 1) Wv_3^2/\lambda$$

where q depends a little on the details of the ballistics. To sum up, A,101 yields

$$\Delta v_3 = -cS/A \quad \text{A,102}$$

where c is of order 2000 f/s., and varies with the propellant used and with such matters as the expansion ratios at all-burnt and ejection. The possible variation in c is a factor of two to one, if all its constituent factors are given their extreme values. Experience suggests that the differences between types of mortar are smaller than the variety existing in other types of artillery. For many purposes c can be taken to be the same for all mortars.

When the bore area A remains unaltered and it is the diameter of the bomb which is reduced to create the leakage area S , the accelerating force on the bomb (at equal pressures) falls in the ratio $(A - S)/A$. This causes a further drop in velocity, which is approximately $v_3 S/2A$ and may be regarded as included in A,102 if c is allowed to depend on velocity. Since the leakage c is much larger than $\frac{1}{2}v_3$, c is only a slowly varying function of velocity, and the ratio $A\Delta v_3/S$ is predicted to be practically the same for all mortars. This is a most useful result.

An 8-cm. mortar may be taken as an example. It was assumed that $\psi = 0.55$, that is, the leakage was taken to be 17 per cent. less than the theoretical value for no friction. This, it will appear, is a fairly good estimate of the resistance to flow past the guide-band of the bomb.

For a typical ballistic solution for this mortar, c was found to be 2500 f/s. Let us write A,102 in another form. Let d be the calibre of the mortar, and Δd the clearance, on diameter, between the bomb and the mortar. Then

$$\Delta v_3 = -2c\Delta d/d \quad \text{A,103}$$

A value of $c = 2500$ f/s., is seen from A,101 to be reasonable if n is about unity. For this mortar

$$\Delta v_3/\Delta d = 1.57 \text{ f/s. per thousandth of an inch} \quad \text{A,104}$$

This is a convenient unit for practical calculations. Suppose that our bombs have a mean deviation in diameter of 0.002 in. ; assuming a rectangular frequency distribution, which is a fair approximation, this mean deviation corresponds to a total tolerance of 0.008 in. on the diameter. This gives a mean deviation in velocity of 3.1 f/s., which is a substantial part of the observed mean deviation.

There is some experimental evidence to check these results. Statistical analyses have been made of firings in 6-cm., 8-cm., and 10.5-cm. mortars. It is convenient to reduce the observed rate of change of velocity with bomb-diameter to what it would be in a calibre of 8 cm., for comparison with A,104. The 10.5-cm. trials gave 1.54 f/s. per thousandth. Firings in an 8-cm. mortar gave 1.7 f/s. per thousandth. Finally, results for a 6-cm. mortar, due to Vinti, have given a mean value of 1.6 f/s. per thousandth. These three sets of results are in excellent agreement with each other and with the theoretical result, showing that the coefficient c of A,102 and A,103 is indeed insensitive to the details of the internal ballistics. That it is little altered by changes in muzzle velocity, within the practical range for mortars, has been verified by computation, and is supported by the experimental results in the 6-cm. mortar with its five standard charges : the results were 1.3, 1.65, 1.8, 1.7, and 1.4 f/s. per thousandth in which no significant trend can be seen.

A.10. The ballistics of a worn gun

In a gun firing separate-loading ammunition, the gradual wearing of the gun is reflected in an increased length of ramming. The ballistic effects are due to the extra chamber capacity and a rather smaller engraving resistance. Gas leakage is very small, and the drop of ballistics in a worn gun can be calculated quite well from the two effects mentioned.

When the gun fires fixed ammunition, the situation is quite different. The wear on the gun does not alter the position at which the shot starts its motion, since this is fixed by the cartridge case, but the length of free run-up is increased. This may be as much as three calibres in a badly worn gun. During this run-up there is considerable leakage of gas between the shot and the walls of the gun. The peak pressure and muzzle velocity fall.

The loss of ballistics as a gun wears is also due in part to the loss of initial resistance and to the enlargement of chamber capacity. It is possible to separate these effects, given enough experimental data in new and old guns, and the theory can be checked if experimental projectiles can be made which will stop the leakage even in the worn gun. An analysis has been carried out on these lines,* with rather incomplete data, and it is hoped that it will be possible to repeat the analysis for the more accurate data now available. Here we shall mention only the theoretical machinery which is used.

* Corner, Vickers and Ware, A.R.D. Theoretical Research Report 26/45 ; AC 8926/BAL 301.

The equations are substantially the same as in Section A.04. One difference is that the pressure to be used in the leakage is the pressure at the base of the shot, which is derived from the breech pressure by the usual Lagrange factor. The leakage area S is now a function of travel, being obtained in any particular example from the dimensions of band and gun. Bore resistance and engraving resistance are practically essential in the treatment, but they make only obvious changes in the equations.

It would lead us rather far afield to discuss the analysis in detail. It will be enough to say that the requirement to fit the data on both new and worn guns, without change in the assumptions about the nature of the bore resistance, is quite stringent, and appears to restrict the degree of arbitrariness which is usually apparent in such matters.

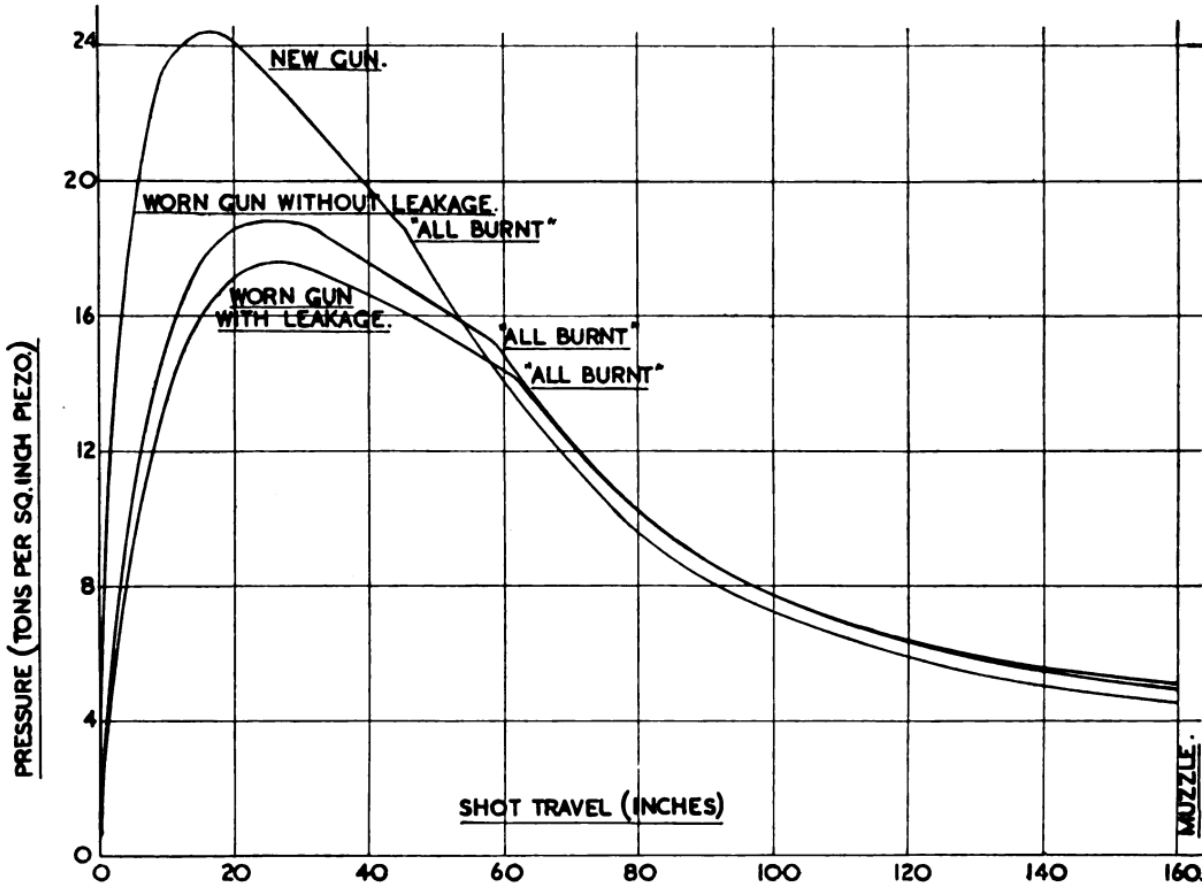

Fig. A.3

Fig. A.3 shows pressure-space curves typical of those calculated for a new gun (without leakage) and a worn gun (with and without leakage). In Fig. A.4 is given the development of the leakage with travel, in a gun which had been eroded by a hot cordite. The fairly marked effects on the pressure-space curve by leakage are produced by a total loss of gas which amounts to no more than one per cent. of the total charge. All but four per cent. of this leakage occurs during the free run-up of 2.7 calibres. The effects of leakage are magnified by the time at which they occur, at the very start of motion, which is the most critical period of the whole process. Since the effect can be simulated by a lower rate of burning during this time, it is possible to cover the gradual wearing of the gun by an increasing central ballistic parameter, which at the same time takes into account the loss of ballistics due to the delaying of the engraving. This last is an important factor in the striking differences between the new-gun and worn-gun

curves. The theoretical results show that the drop of muzzle velocity in this gun is divisible between loss of initial resistance, gas leakage, and changes of internal dimensions, in the proportions of 65 : 20 : 15, roughly.

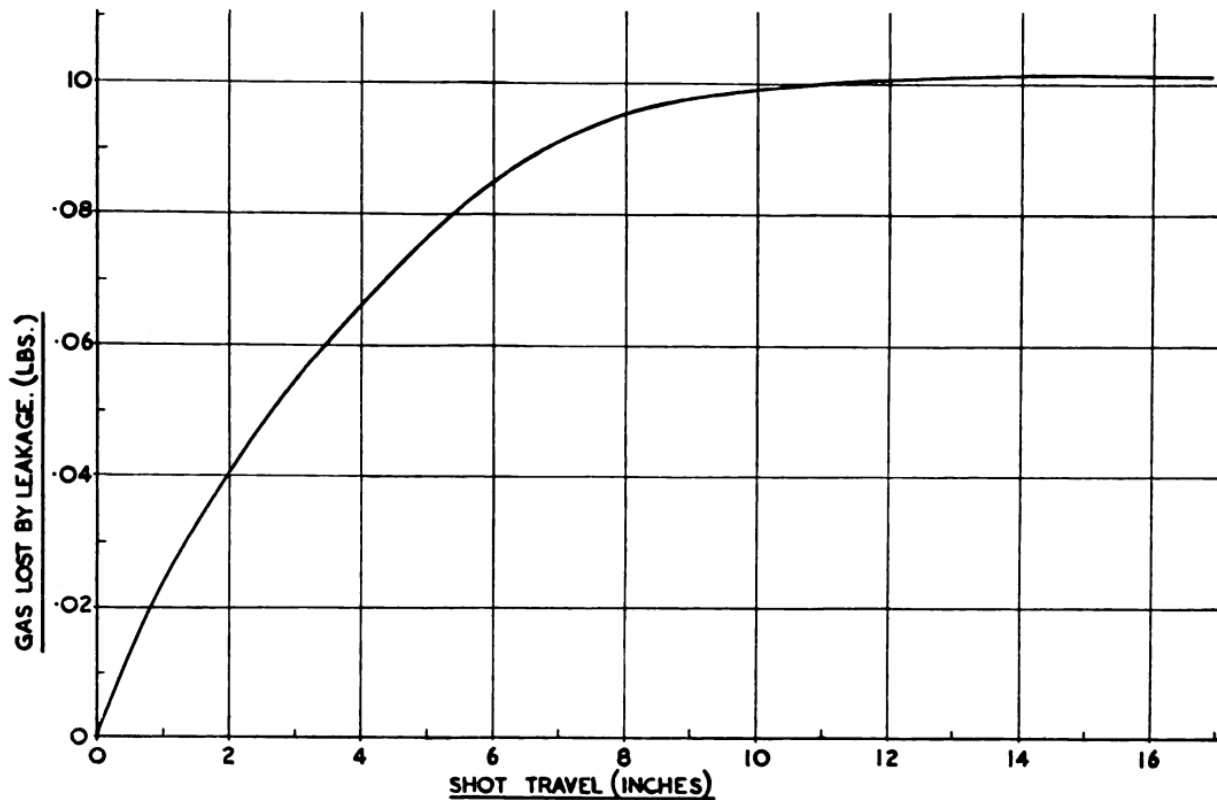

Fig. A.4

A.11. Recoillessness

We turn now to an important kind of leaking gun, the recoilless gun. Two kinds of *recoillessness* are possible :—

- (a) If the flow out of the nozzle begins at the same time as the shot starts and there is no resistance to motion afterwards, then it is possible to find a nozzle throat area which gives zero resultant force on the gun at all times during the firing, including the post-ejection period.
- (b) If the flow through the nozzle is established at a pressure different from the shot-start pressure, then only a more restricted recoillessness can be achieved. Suppose, for example, that the gas flow starts before the shot moves. It is obvious that until the shot starts there is a resultant forward thrust on the gun. To get zero momentum of the gun after the firing is over, there must be a resultant backward thrust while the shot is in motion. The zero final momentum means a negligible total movement, since the forces last for only a short time. This state of affairs would be described in trials reports as recoillessness ; it is clear, nevertheless, that the carriage would have to withstand large impulsive forces.

Recoillessness of type (a) is obviously a very special case, implying a particular form of resistance to motion as well as a certain suitable choice of bursting-disc. However, it can be approached sufficiently nearly, for all practical purposes, to justify our separating such cases into a separate class.

Both types of recoillessness are considered here. Case (b) is by far the more common.

The stress on the carriage depends on whether this is rigidly attached to the ground. If it is so attached, for example, by spades, then the whole of the momentary thrust on the gun is transmitted to the carriage. If, on the other hand, the carriage is free to move, only a part of the thrust appears at the gun-carriage junction; the rest is used in acceleration of the piece itself. A carriage weighing as much as the piece would receive half of the resultant thrust on the piece.

The ballistic properties of a recoilless gun depend quite strongly on the relation between nozzle-start and shot-start pressures. It is useful, therefore, to be able to detect whether one is working in region (a) or (b), and in the latter case to say which pressure is the larger.

Now, if a certain gun has been adjusted to be recoilless at normal charge, with nozzle opening before the shot starts, then, if fired with a smaller charge of the same propellant, the gun will move forward. This is quite obvious, since in the latter case the period during which $p_N < p < p_0$, in which therefore the system is acting as a rocket, is longer than before. This is the simplest practical test for the relative timing of nozzle-opening and shot-start. The gun movements to be expected are not very large—an inch or two if mounted on a rubber-tyred carriage on smooth ground.

A.12. The calculation of recoil momentum

When the shot is rigidly held in the shot-seating, the thrust forward on the gun is, by the theory of Section A.03, $\zeta S p$ where the dimensionless thrust coefficient $\zeta = P/p_r S_t$ has been tabulated in Table A.1. When the shot is free to move along the bore the thrust on the gun falls by $A p$, reducing the net forward thrust to $(\zeta S - A)p$; writing $\mu = S/A$, this thrust is $(\mu \zeta - 1)A p$.

The coefficient ζ depends on the γ of the propellant gases and, more strongly, on the expansion ratio of the nozzle used. These characteristics of propellant and gun are effectively constant during the firing. The coefficient ζ has also a small dependence on ϵ , the parameter measuring the co-volume effect:

$$\epsilon = b\rho/(1 - b\rho)$$

For the most accurate work, this dependence on ϵ can be taken into account by using a ζ which is a function of time, perhaps in the form of different mean ζ in various parts of the solution. In the formulae which follow we shall not explicitly distinguish the various ζ .

We have, for the total backward momentum of the gun at shot-ejection,

$$A(1 - \mu\zeta) \int_{t_s}^{t_3} p dt - A\mu\zeta \int_{t_N}^{t_s} p dt$$

For all solutions of good ballistic regularity, all-burnt occurs before shot-ejection, and we can take the system after shot-ejection as a reservoir of gas exhausting through nozzles in parallel, of throat areas S and A . By Hugoniot's theory, we have

$$p = (CN_3 RT_3 / K_3) (1 + t/\Omega_1)^{-2\gamma/(\gamma-1)}$$

where t is measured from shot ejection, K_3 is the total internal volume of the gun, and

$$\Omega_1 = \frac{2}{\gamma-1} \frac{K_3}{A+S} \left[\frac{\{\frac{1}{2}(\gamma+1)\}^{(\gamma+1)(\gamma-1)}}{\gamma RT_3} \right]^{\frac{1}{2}}$$

These formulae neglect the effect of co-volume. The gain in backward momentum after shot-ejection is

$$A(1 - \mu\zeta) \int_0^{\infty} p dt = \frac{(1 - \mu\zeta) CN_3}{1 + \mu} \left[\frac{RT_3}{\gamma} \right]^{\dagger} \left[\frac{\gamma + 1}{2} \right]^{(3-\gamma)/2(\gamma-1)} \quad \text{A,105}$$

The function of γ which occurs in A,105 is equal to 1.34 within 3 per cent. for all Service propellants.

It is convenient to write the total momentum of the gun after firing as Wv_r , where v_r is a *virtual shot velocity*. For a gun with exactly-balanced recoil v_r is zero. From the formulae above,

$$v_r = \frac{A(1 - \mu\zeta)}{W} \left[\int_{t_0}^{t_3} p dt + \frac{1.34CN_3(RT_3)^{\dagger}}{1 + \mu} \right] - \frac{A\mu\zeta}{W} \int_{t_N}^{t_0} p dt \quad \text{A,106}$$

In terms of the reduced units introduced in Section A.06,

$$\frac{Wv_r}{C\sqrt{RT_0}} = (1 - \mu\zeta) \left[\int_{\tau_0}^{\tau_3} \Pi d\tau + \frac{1.34N_3\sqrt{T_3'}}{1 + \mu} \right] - \mu\zeta \int_{\tau_N}^{\tau_0} \Pi d\tau \quad \text{A,107}$$

Up to all-burnt in a numerical integration, $\int_{\tau_0}^{\tau_2} \Pi d\tau$ can be found by a summation, since increments of this quantity appear in the computation.

After all-burnt,

$$\int_{\tau_2}^{\tau_3} \Pi d\tau = (\bar{W}_1/C) [(d\xi/d\tau)_3 - (d\xi/d\tau)_2]$$

When the quicker method of Section A.07 is used, the virtual shot velocity can be calculated from

$$Wv_r = (1 - \mu\zeta) [\bar{W}_1 v_2 + \bar{W}_1' (v_3 - v_2) + 1.34CN_3 (RT_3)^{\dagger}/(1 + \mu)] - \mu\zeta (AD/\beta) (f_N - f_0) \quad \text{A,108}$$

where \bar{W}_1 is the mean W_1 from shot-start to all-burnt and \bar{W}_1' that from all-burnt to shot-ejection. Both occur in the ballistic solution itself.

If a bore-resistance, depending on travel, is preferred to an instantaneous collapse of the shot-start pressure, the formulae of this Section must be rewritten, but the changes to be made are quite obvious.

A.13. The high-low pressure gun

The lethal effect of a projectile of given weight is often increased if we can design it for a low maximum pressure. For example, this holds for high-explosive shell against unprotected troops. Likewise the effect of a hollow-charge against armour is not strongly dependent on the weight of the walls, so that a given penetration can be achieved with a lighter projectile if the maximum pressure can be lowered; this means a lower muzzle energy and a lighter gun. A low peak pressure may also lower the piece weight for given muzzle energy, depending, however, on just how this lower peak pressure is obtained.

Low-pressure weapons show difficulties of ignition, presumably because the pressure builds up so slowly, and the round-to-round variations are apt to be large.

A notable advance in low-pressure guns was made during the war by German engineers. The front of the cartridge case was closed by a plate pierced by one or several nozzles, usually in the form of plain holes. By choice of the nozzle area the pressure in the chamber was kept considerably higher than in the bore. The projectile was exposed to only a low pressure; the bore had to be of the same length as in an ordinary low-pressure gun; the important point is that the cordite burned under a pressure two or three times that in the bore, and ignition and regularity were claimed to be improved. Finally, another advantage was that the volume of the cartridge case was reduced. The plate carrying the nozzles was an integral part of the cartridge case, and could be used several times.

To sum up, the "Hoch-und-niederdruck Kanone" is claimed to have the following advantages over the orthodox gun of equal muzzle energy and peak bore pressure: better regularity; smaller cartridge. The breech is heavier in the high-low pressure gun, and the piece is slightly heavier.

Claims that the H-L principle gives a lighter gun are true only in a restricted sense. What is true is that (i) if the target effect of the projectile is improved (per unit total weight of projectile) by a light construction, and (ii) if the gun is to be accurate, and (iii) if we can tolerate the large bore volumes made necessary by a low working pressure, then the H-L gun will be lighter than an ordinary high-pressure gun, and more accurate than an orthodox low-pressure gun.

We shall now give a simple theory of the internal ballistics of the H-L gun, of essentially the same order of accuracy as Crow's method (Section 9.08).

A.14. Notation and assumptions

The gun can be idealised to the form shown in Fig. A.5. Let the projectile and charge weights be W and C . The charge is contained in the first chamber of volume K and before the shot moves the total volume behind it is $K + K_0$. Let S be the throat area of the venturi or nozzles connecting the two chambers, and A the bore area.

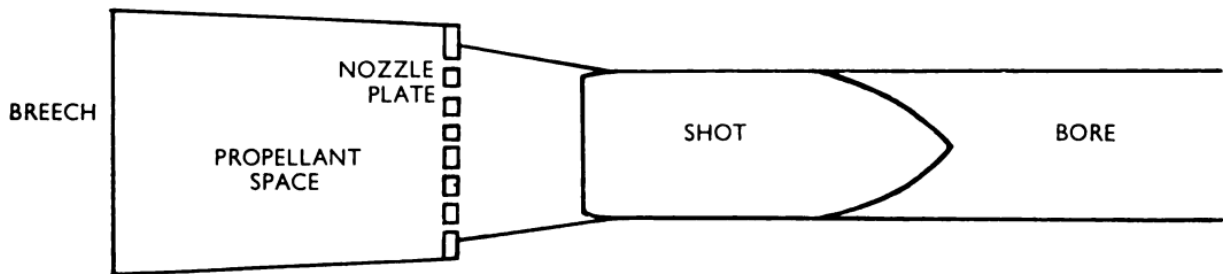

Fig. A.5

Let P be the pressure in the main chamber, assumed uniform throughout the chamber, and let p be the space-mean pressure in the bore and second chamber. We write v for the shot velocity at travel x .

Let Cz be the amount of cordite burnt up to time t , and let CN be the amount of gas in the first chamber at that time.

We assume the form-function

$$z = 1 - f$$

The common shapes, tube, slotted-tube, ribbon, and multi-tube, have form-factors θ sufficiently near zero to make successful analysis possible with $\theta = 0$. Only for cord is A,109 inadequate. This case is left as an exercise for the reader.

We assume the conventional Lagrange correction, which ought to be little, if any, more wrong than in an orthodox gun. Hence

$$w_1 \, dv/dt = A p \quad \text{A,110}$$

where

$$w_1 = W + \frac{1}{3} C \quad \text{A,111}$$

We assume a rate of burning proportional to pressure, that is,

$$Ddf/dt = -\beta P \quad \text{A,112}$$

We adopt the isothermal approximation, in which a mean temperature of the propellant gases is assumed throughout the period of burning of the charge. Let the corresponding force-constant be λ . This applies throughout both chambers and bore and we neglect the small regions near the venturi where other conditions hold.

We represent the initial resistance to motion of the shot by a change of effective rate of burning. The rate β is the adjusted rate. It will be seen that in this and the preceding assumption we are following Crow's method (Section 9.08). This is chiefly to make more obvious the relation to orthodox guns, but it also leads to a great saving of labour.

The pressures at inlet and exit of the nozzle are P and p as near as matters. If

$$p/P \leq [2/(\gamma + 1)]^{\gamma/(\gamma-1)} \quad \text{A,113}$$

then the rate of flow is settled by P alone. This is a familiar result in the one-dimensional theory of nozzles. There should, as a matter of fact, be a co-volume correction to this critical ratio, the magnitude of which has been worked out by Rateau and discussed in Section A.02. The correction amounts to about 7 per cent. for $\gamma = 1.25$ and $P = 25$ tons/sq. in. For this value of γ , the condition A,113 is $p/P \leq 0.555$.

The co-volume also alters the rate of flow at a given pressure; it can be shown that the error is less than 7 per cent. for pressures up to 25 tons/sq. in. Thus we shall omit co-volume effects on the flow between the two chambers, but *not* the direct effect on the equation of state.

For P and p satisfying A,113, the rate of flow is

$$\psi SP/\sqrt{\lambda} \quad \text{A,114}$$

where ψ is a numerical factor which depends on γ but lies within 1 per cent. of 0.66 for all Service propellants. A correction for friction and heat losses in the nozzle should be included in ψ ; a 5 per cent. reduction, which is reasonable, makes ψ about 0.63.

If p/P is greater than the limit mentioned in A,113, the rate of flow is, for $\gamma = 1.25$,

$$(\chi SP/\sqrt{\lambda}) (p/P)^{0.8} [1 - (p/P)^{0.2}]^{\frac{1}{2}} \quad \text{A,115}$$

where χ is 3.162 for $\gamma = 1.25$ and no friction losses. With allowance for friction one may take $\chi = 3.00$. Another way to express the difference between A,115 and A,114 is by their ratio, which can be regarded as the factor representing the effect of back-pressure on the flow. Table A.2 shows some typical values, and will be found useful in approximate calculations when p/P exceeds 0.55.

Table A.2. The back-pressure factor

| p/P | Factor | p/P | Factor |
|-------|--------|-------|--------|
| 0.56 | 1 | 0.94 | 0.507 |
| 0.6 | 0.995 | 0.96 | 0.419 |
| 0.7 | 0.948 | 0.98 | 0.300 |
| 0.8 | 0.840 | 0.99 | 0.214 |
| 0.85 | 0.755 | 0.997 | 0.117 |
| 0.9 | 0.638 | 1 | 0 |

We shall assume that p/P remains throughout at less than the critical value A,113. The great simplicity which this introduces into the mathematics will be seen later. This assumption seems to be always obeyed in the practical examples produced up to now.

We assume that no unburnt cordite passes the nozzle. This is probably true in the later types of H-L guns with a number of small nozzles in parallel between the two chambers. With normal ignition no appreciable error is expected from this assumption.

A.15. Equations of internal ballistics, up to all-burnt

THE FIRST CHAMBER

The equation of state for the gas in the first chamber is

$$P [K - C (1 - z)/\delta - CNb] = CN\lambda \quad \text{A,116}$$

and for that in the second chamber and bore is

$$p [K_0 + Ax - C (z - N) b] = C\lambda (z - N) \quad \text{A,117}$$

Also

$$dN/dt = dz/dt - \psi SP/C\sqrt{\lambda} \quad \text{A,118}$$

$$= [\beta/D - \psi S/C\sqrt{\lambda}] P \quad \text{A,119}$$

since

$$dz/dt = \beta P/D \quad \text{A,120}$$

Hence

$$N = (1 - \Psi) z \quad \text{A,121}$$

where

$$\Psi = \psi SD/\beta C\sqrt{\lambda} \quad \text{A,122}$$

The dimensionless parameter Ψ was found to play a fundamental part in the ballistics of recoilless guns, where S was the throat area of the venturi in the breech ; Ψ plays an equally important part in the theory of H-L guns, for which it is of order 0.5.

Substituting from A,121 into A,116, we have

$$\begin{aligned} C\lambda (1 - \Psi) z &= P [K - (1 - z) C/\delta - (1 - \Psi) Cz b] \\ &= P [K - C/\delta - (1 - \Psi) Cz \{ b - 1/\delta (1 - \Psi) \}] \end{aligned} \quad \text{A,123}$$

Thus the pressure builds up in the first chamber as if it were a closed vessel with charge $C(1 - \Psi)$, co-volume b , density $\delta(1 - \Psi)$, and web-size D .*

From A,120 and A,123,

$$dz/dt = \mu z / (1 + Bz) \quad \text{A,124}$$

where

$$\mu = \beta C \lambda (1 - \Psi) / D (K - C/\delta) \quad \text{A,125}$$

and

$$B = C [1/\delta - b(1 - \Psi)] / (K - C/\delta) \quad \text{A,126}$$

Note that B may have either sign.

Taking the origin of time when $z = 1$, the solution of A,124 is

$$\mu t = \ln z - B(1 - z) \quad \text{A,127}$$

The pressure in the first chamber is

$$P = \frac{C\lambda(1 - \Psi)}{K - C/\delta} \frac{z}{1 + Bz} \quad \text{A,128}$$

whose maximum value occurs at all-burnt and is

$$P_2 = \frac{C\lambda(1 - \Psi)}{(K - C/\delta)(1 + B)} = \frac{C\lambda(1 - \Psi)}{K - (1 - \Psi)Cb} \quad \text{A,129}$$

THE SECOND CHAMBER AND BORE

The equations for the second chamber and the bore are simply

$$w_1 dv/dt = Ap \quad \text{A,130}$$

and

$$p = C\lambda z \Psi / (K_0 + Ax - C\Psi bz) \quad \text{A,131}$$

Hence

$$\frac{dv}{dz} = \frac{AC\lambda\Psi(1 + Bz)}{w_1\mu(K_0 + Ax - C\Psi bz)} \quad \text{A,132}$$

If K_0 is not zero, then for small z

$$p = C\lambda z \Psi / K_0 \quad \text{and} \quad P = C\lambda z (1 - \Psi) / (K - C/\delta)$$

so that initially

$$p/P = \Psi(K - C/\delta) / K_0(1 - \Psi) \quad \text{A,133}$$

Returning to A,132, we write, in general

$$X = (K_0 + Ax) (\mu/A) (w_1/C\lambda\Psi)^{\dagger} \quad \text{A,134}$$

* cf. equation 5,05.

which with A,132 leads to

$$\frac{d}{dz} \left[\frac{z}{1 + Bz} \frac{dX}{dz} \right] = \frac{1 + Bz}{X - \nu z} \quad \text{A,135}$$

where

$$\nu = (\mu b/A) (w_1 C \Psi / \lambda)^{\dagger} \quad \text{A,136}$$

The constants B and ν will both be small. It is easy to show that ν is roughly $2b\bar{p}/\lambda$, where \bar{p} is the space-mean pressure on the shot up to all-burnt. For a gun working at $\bar{p} = 8$ tons/sq. in., which is not likely to be exceeded in H-L guns, ν is less than 0.3. The value of B increases with the density of loading, and for a density of loading of 0.8 gm./c.c. the limits of B are -0.6 and $+1$. For practical values of Ψ the range of B is -0.5 to $+0.5$. We may expect, therefore, that for H-L guns B will usually be small but larger than ν .

Generally, the integration of A,135 is best effected numerically. The boundary conditions are, $z dX/dz = 0$ and $X = X_0$ when $z = 0$.

The pressure, velocity and shot-travel at any value of z between 0 and 1 are, respectively,

$$p = (\mu/A) (w_1 C \lambda \Psi)^{\dagger} / (X/z - \nu) \quad \text{A,137}$$

$$v = (C \lambda \Psi / w_1)^{\dagger} z (dX/dz) / (1 + Bz) \quad \text{A,138}$$

$$x = (C \lambda \Psi / w_1)^{\dagger} (X - X_0) / \mu \quad \text{A,139}$$

where

$$X_0 = (K_0 \mu / A) (w_1 / C \lambda \Psi)^{\dagger} \quad \text{A,140}$$

It was found, in the course of the calculation, that X/z generally decreased steadily as z approached unity, within the limits of B and ν mentioned above. The maximum pressure, therefore, occurs at all-burnt or so near that the value of the pressure at all-burnt is a sufficiently good approximation. We are, therefore, interested in the pressure, velocity and shot-travel at all-burnt only and the results of the calculation can be tabulated quite simply, as in Tables A.3, A.4 and A.5.

Linear interpolation leads to errors of, in the worst case, 0.002 in $X_2/(2 + X_0)$ and 1 in 400 in $(dX/dz)_2$. Other errors can arise from our approximate representation of the computed results, so that these possible errors should be doubled. This accuracy is ample in view of the simplifying assumptions made in our theory.

SERIES SOLUTIONS

The general solution of A,135 can be expressed as a power series in z as follows :—

$$\begin{aligned} X = X_0 + \frac{z}{X_0} + \left[\frac{3B}{4X_0} + \frac{\nu X_0 - 1}{4X_0^3} \right] z^2 \\ + \left[\frac{(\nu X_0 - 1)^2}{9X_0^5} - \frac{\nu X_0 - 1}{36X_0^5} - \frac{B}{12X_0^3} + \frac{5B(\nu X_0 - 1)}{18X_0^3} + \frac{B^2}{6X_0} \right] z^3 + \dots \quad \text{A,141} \end{aligned}$$

Unfortunately this series does not converge sufficiently rapidly for general use, but for $X_0 \geq 5$ the terms given in A,141 yield X and dX/dz sufficiently accurately ; for this reason values have not been given in the Tables for $X_0 > 5$.

When $X_0 = 0$ the solution is

$$X = 2z^{\dagger} + \frac{\nu}{5} z + \left[\frac{4B}{5} + \frac{4\nu^2}{125} \right] z^{3/2} + \frac{44B\nu}{425} z^2 + \frac{19B^2}{325} z^{5/2} + 0 (B\nu z^{5/2}) + 0 (\nu^2 z^3) \quad \text{A,142}$$

Table A.3
Values of $X_2/(2 + X_0)$ as a power-series in B and ν
 (The coefficients should be interpolated linearly with respect to X_0)

| | | | | | |
|-----------------|-------|----------|-----------------------|--------------|---------------|
| X_0 | | | | | |
| 0 | 1.000 | +0.400 B | +0.032 B ² | +0.100 ν | +0.05 B ν |
| .05 | 0.964 | | | | |
| .1 | 0.928 | | | | |
| .15 | 0.894 | | | | |
| .2 | 0.861 | +0.355 B | | | |
| .25 | 0.830 | | | +0.095 ν | |
| .3 | 0.801 | | | | |
| .35 | 0.773 | | | | |
| .4 | 0.747 | +0.308 B | | | |
| .45 | 0.724 | | | | |
| .5 | 0.703 | | +0.030 B ² | +0.085 ν | +0.05 B ν |
| .55 | 0.687 | | | | |
| .6 | 0.674 | +0.262 B | | | |
| .65 | 0.662 | | | | |
| .7 | 0.651 | +0.239 B | | | |
| .75 | 0.642 | | | +0.065 ν | |
| .8 | 0.634 | +0.218 B | | | |
| .9 | 0.621 | +0.198 B | | | |
| 1.0 | 0.611 | +0.181 B | +0.025 B ² | +0.045 ν | +0.03 B ν |
| 1 $\frac{1}{4}$ | 0.604 | +0.162 B | | | |
| 1 $\frac{1}{2}$ | 0.600 | +0.146 B | | +0.033 ν | |
| 1 $\frac{3}{4}$ | 0.600 | +0.132 B | | | |
| 1 $\frac{1}{2}$ | 0.602 | +0.120 B | +0.020 B ² | +0.025 ν | |
| 1 $\frac{3}{4}$ | 0.609 | +0.100 B | | | |
| 2 | 0.618 | +0.084 B | +0.016 B ² | +0.015 ν | +0.01 B ν |
| 2 $\frac{1}{2}$ | 0.641 | +0.061 B | +0.013 B ² | +0.009 ν | |
| 3 | 0.665 | +0.047 B | +0.010 B ² | +0.005 ν | |
| 3 $\frac{1}{2}$ | 0.688 | +0.037 B | +0.007 B ² | +0.002 ν | |
| 4 | 0.708 | +0.030 B | +0.005 B ² | +0.000 ν | |
| 4 $\frac{1}{2}$ | 0.726 | +0.025 B | +0.003 B ² | | |
| 5 | 0.743 | +0.021 B | +0.002 B ² | +0.000 ν | +0.01 B ν |

Table A.4

$$\text{Values of } \frac{1 + X_0}{1 + B} \left(\frac{dX}{dz} \right)_2$$

(The coefficients should be interpolated linearly with respect to X_0)

| | | | | | |
|-------|-------|----------|-----------------------|----------|-----------|
| X_0 | | | | | |
| 1.1 | 1.425 | +0.515 B | -0.081 B ² | +0.401 v | +0.07 Bv |
| 1.3 | 1.410 | +0.542 B | | +0.378 v | |
| 1.5 | 1.392 | +0.560 B | -0.070 B ² | +0.350 v | +0.125 Bv |
| 1½ | 1.368 | +0.576 B | | | |
| 2 | 1.344 | +0.585 B | -0.054 B ² | +0.285 v | +0.12 Bv |
| 2½ | 1.322 | +0.590 B | | | |
| 2½ | 1.301 | +0.593 B | -0.034 B ² | +0.234 v | +0.115 Bv |
| 3 | 1.264 | +0.592 B | -0.016 B ² | +0.200 v | +0.10 Bv |
| 3½ | 1.234 | +0.587 B | -0.008 B ² | +0.174 v | +0.09 Bv |
| 4 | 1.210 | +0.580 B | -0.000 B ² | +0.152 v | +0.08 Bv |
| 4½ | 1.191 | | | +0.135 v | |
| 5 | 1.175 | +0.564 B | +0.037 B ² | +0.123 v | +0.05 Bv |

Table A.5

$$\text{Values of } \frac{1}{1 + B} \left(\frac{dX}{dz} \right)_2$$

(The coefficients should be interpolated linearly with respect to X_0)

| | | | | | |
|-------|-------|----------|-----------------------|----------|----------|
| X_0 | | | | | |
| 0 | 1.000 | +0.217 B | -0.070 B ² | +0.210 v | +0.00 Bv |
| .05 | 1.018 | | | | |
| .1 | 1.027 | +0.226 B | | +0.235 v | |
| .15 | 1.029 | | | | |
| .2 | 1.025 | +0.234 B | | +0.253 v | |
| .25 | 1.015 | | | | |
| .3 | 1.000 | +0.241 B | | +0.264 v | |
| .4 | 0.965 | +0.247 B | | +0.268 v | |
| .5 | 0.924 | +0.251 B | -0.056 B ² | +0.265 v | +0.01 Bv |
| .6 | 0.881 | +0.253 B | | +0.257 v | |
| .7 | 0.837 | +0.254 B | | +0.247 v | |
| .8 | 0.795 | +0.253 B | | +0.233 v | |
| .9 | 0.754 | +0.252 B | | +0.220 v | |
| 1.0 | 0.715 | +0.249 B | -0.042 B ² | | +0.03 Bv |
| 1.1 | 0.678 | +0.245 B | | +0.191 v | |

Table A.4

$$\text{Values of } \frac{1 + X_0}{1 + B} \left(\frac{dX}{dz} \right)_2$$

(The coefficients should be interpolated linearly with respect to X_0)

| | | | | | |
|-------|-------|----------|-----------------------|----------|-----------|
| X_0 | | | | | |
| 1.1 | 1.425 | +0.515 B | -0.081 B ² | +0.401 v | +0.07 Bv |
| 1.3 | 1.410 | +0.542 B | | +0.378 v | |
| 1.5 | 1.392 | +0.560 B | -0.070 B ² | +0.350 v | +0.125 Bv |
| 1½ | 1.368 | +0.576 B | | | |
| 2 | 1.344 | +0.585 B | -0.054 B ² | +0.285 v | +0.12 Bv |
| 2½ | 1.322 | +0.590 B | | | |
| 2½ | 1.301 | +0.593 B | -0.034 B ² | +0.234 v | +0.115 Bv |
| 3 | 1.264 | +0.592 B | -0.016 B ² | +0.200 v | +0.10 Bv |
| 3½ | 1.234 | +0.587 B | -0.008 B ² | +0.174 v | +0.09 Bv |
| 4 | 1.210 | +0.580 B | -0.000 B ² | +0.152 v | +0.08 Bv |
| 4½ | 1.191 | | | +0.135 v | |
| 5 | 1.175 | +0.564 B | +0.037 B ² | +0.123 v | +0.05 Bv |

Table A.5

$$\text{Values of } \frac{1}{1 + B} \left(\frac{dX}{dz} \right)_2$$

(The coefficients should be interpolated linearly with respect to X_0)

| | | | | | |
|-------|-------|----------|-----------------------|----------|----------|
| X_0 | | | | | |
| 0 | 1.000 | +0.217 B | -0.070 B ² | +0.210 v | +0.00 Bv |
| .05 | 1.018 | | | | |
| .1 | 1.027 | +0.226 B | | +0.235 v | |
| .15 | 1.029 | | | | |
| .2 | 1.025 | +0.234 B | | +0.253 v | |
| .25 | 1.015 | | | | |
| .3 | 1.000 | +0.241 B | | +0.264 v | |
| .4 | 0.965 | +0.247 B | | +0.268 v | |
| .5 | 0.924 | +0.251 B | -0.056 B ² | +0.265 v | +0.01 Bv |
| .6 | 0.881 | +0.253 B | | +0.257 v | |
| .7 | 0.837 | +0.254 B | | +0.247 v | |
| .8 | 0.795 | +0.253 B | | +0.233 v | |
| .9 | 0.754 | +0.252 B | | +0.220 v | |
| 1.0 | 0.715 | +0.249 B | -0.042 B ² | | +0.03 Bv |
| 1.1 | 0.678 | +0.245 B | | +0.191 v | |

A.16. Internal ballistics after all-burnt

So long as $p/P < 0.555$, the gas flow from the first chamber is the same as if p were zero, and the rate of decay of pressure P is given by Hugoniot's theory with Rateau's corrections for co-volume (cf. A.R.D. Ballistics Report 54/43).

It is hoped however, that co-volume corrections to the flow will be negligible in H-L guns. In such a case,

$$P = P_2 (1 + t/\Omega_2)^{-2\gamma/(\gamma-1)} \quad \text{A,143}$$

and

$$N = N_2 (1 + t/\Omega_2)^{-2/(\gamma-1)} = (1 - \Psi) (1 + t/\Omega_2)^{-2/(\gamma-1)} \quad \text{A,144}$$

where

$$\Omega_2 = 2K/(\gamma - 1) \Psi \sqrt{\lambda} \quad \text{A,145}$$

The gas in the second chamber and bore also expands adiabatically. The equations are

$$p = \frac{C\lambda (1 - N) T'}{K_0 + Ax - (1 - N) Cb} \quad \text{A,146}$$

$$w_1 dv/dt = Ap \quad \text{A,147}$$

together with the equation of energy

$$[C\lambda/(\gamma - 1)] [\Psi - (1 - N) T'] = \frac{1}{2} w_1 (v^2 - v_2^2) \quad \text{A,148}$$

We have written T' for the ratio of the gas temperature to the mean value which it had during burning. Differentiating A,148 and using A,146 and A,147 we have

$$T' \frac{dN}{dt} - (1 - N) \frac{dT'}{dt} = \frac{(\gamma - 1) (1 - N) T' A}{K_0 + Ax - (1 - N) Cb} \frac{dx}{dt}$$

which integrates to

$$\log \frac{(1 - N) T'}{\Psi} = -(\gamma - 1) \log \frac{K_0 + Ax - (1 - \bar{N}) Cb}{K_0 + Ax_2 - (1 - \bar{N}) Cb} \quad \text{A,149}$$

To obtain the muzzle-velocity, therefore, we guess \bar{N} for the period after all-burnt, determine $(1 - N) T'$ from A,149, and the muzzle velocity from A,148. The mean velocity after all-burnt gives the epoch of shot-ejection and so, from A,144, the value of N at that instant. We then verify that our first \bar{N} was sufficiently accurate.

Finally we insert our value of $(1 - N) T'$ in A,146 and our estimate for the time of shot-ejection in A,143, and examine whether p/P is still less than 0.555 at the muzzle.

Although A,144 and A,145 apply only if p/P is less than 0.555, the equations A,148 and A,149 are always true. If p/P is greater than 0.555 for part or all of the period after all-burnt, Ψ in A,145 should be multiplied by an appropriate back-pressure factor from Table A.2. A,144 can still be used, as an approximation, with the new and larger value of Ψ , when finding \bar{N} for the period after all-burnt.

A.17. Summary of the working formulae

In practice one is interested only in certain salient features of the ballistic solution. The first of these is the peak pressure in the cordite chamber :

$$P_2 = \frac{C\lambda (1 - \Psi)}{K - (1 - \Psi) Cb} \quad \text{A,129}$$

where

$$\Psi = \psi SD / \beta C \sqrt{\lambda} \quad \text{A,122}$$

If p/P is found to be greater than 0.555 for all or part of the time, Ψ is multiplied by an appropriate back-pressure factor from Table A.2.

We calculate

$$\mu = \beta C \lambda (1 - \Psi) / D (K - C/\delta) \quad \text{A,125}$$

and from the initial volume K_0 of the second chamber we find

$$X_0 = (K_0 \mu / A) (w_1 / C \lambda \Psi)^{\dagger} \quad \text{A,140}$$

where

$$w_1 = W + \frac{1}{3} C \quad \text{A,111}$$

We work out

$$B = C [1/\delta - b (1 - \Psi)] / (K - C/\delta) \quad \text{A,126}$$

and

$$v = (\mu b / A) (w_1 C \Psi / \lambda)^{\dagger} \quad \text{A,136}$$

From Tables A.3, 4 and 5 we obtain X_2 and $(dX/dz)_2$. Then the peak pressure in the bore is

$$p_2 = (\mu / A) (w_1 C \lambda \Psi)^{\dagger} / (X_2 - v) \quad \text{A,137}$$

the travel at all-burnt is

$$x_2 = (C \lambda \Psi / w_1)^{\dagger} (X_2 - X_0) / \mu \quad \text{A,139}$$

and the velocity at all-burnt is

$$v_2 = \frac{(C \lambda \Psi / w_1)^{\dagger}}{1 + B} \left(\frac{dX}{dz} \right)_2 \quad \text{A,138}$$

It only remains to find the muzzle velocity. At all-burnt, $N_2 = 1 - \Psi$. We guess \bar{N} for the period from all-burnt to shot-ejection, and calculate $(1 - N)T'$ from

$$\log \frac{(1 - N) T'}{\Psi} = -(\gamma - 1) \log \frac{K_0 + Ax_3 - (1 - \bar{N}) Cb}{K_0 + Ax_2 - (1 - \bar{N}) Cb} \quad \text{A,149}$$

The muzzle velocity then comes from

$$v_3^2 = v_2^2 + 2 [C \lambda / w_1 (\gamma - 1)] [\Psi - (1 - N) T'] \quad \text{A,148}$$

The mean velocity after all-burnt gives the epoch of shot-ejection and so the value of N at that time, from

$$N = (1 - \Psi) (1 + t/\Omega_2)^{-2/(\gamma-1)} \quad \text{A,144}$$

where

$$\Omega_2 = 2K/(\gamma - 1) \psi S \sqrt{\lambda} \quad \text{A,145}$$

\bar{N} is calculated and, if necessary, the muzzle velocity repeated with this better \bar{N} .

APPENDIX II

The Heating of a Gun Barrel by the Propellant Gases

In theoretical calculations of the internal ballistics of a gun, it is necessary to allow for the energy lost by the propellant gases, in the form of heat, to the gun itself. It is important, therefore, to determine this heat-loss precisely : first, in order to estimate its effect on the calculated ballistics of a gun ; and secondly, to derive the temperatures attained by the barrel.

The objects of this investigation, then, are :—

- (a) To determine the magnitude of the total heat-loss to the gun barrel, and its relation to the final distribution of the energy released by the burning of the charge.
- (b) To determine the heat-loss up to any time before ejection of the shot ; the rate at which the gases lose heat to the barrel is fundamental in adjusting the energy equation (Résal's equation) of internal ballistics, to allow for heat losses (see Chapter VI).
- (c) To determine the heat transfer at different positions along the barrel, and the local temperatures in the barrel ; these are relevant to certain theories on the erosion of guns.
- (d) Having obtained these results theoretically for a selection of numerical cases, to examine the possibility of deriving corresponding data for any gun, by shorter empirical methods.

The theoretical investigation resolves itself into two main problems :—

- (a) The determination of the conditions governing heat transfer from the propellant gases to the barrel wall. Heat is transferred mainly by forced convection through a turbulent boundary layer, and, to make the problem tractable, it was necessary to adopt certain simplifying assumptions. With these assumptions, it was found possible to derive the heat transfer, taking some account of both the non-steady and non-uniform nature of the gas flow.
- (b) The solution of the equation of heat conduction inside the gun barrel. The boundary condition at the inner wall follows directly from the results of the first main problem, and the effect of the outer wall was found to be negligible. The problem has been solved by a method which is suitable for small-arc computation.

Numerical results could only be compiled in those cases for which detailed solutions of the internal-ballistics equations were available. Such solutions have been obtained on the Bush Differential Analyser at Cambridge, neglecting heat losses, and the results have been used in the following cases : (a) the two-pounder gun model, (b) the 25-pounder gun, and (c) the 8-inch gun, Mark VIII, with four different charge weights. In each of these cases, the heat-loss to the gun has been completely evaluated.

The total heat-loss to the barrel, up to the time of ejection of the shot, was found to lie between 4 per cent. and 9 per cent. of the total energy liberated, in all the cases considered. The heat-loss up to any time was found to be roughly proportional to the distance travelled by the shot. The maximum temperature attained by the barrel was, in every case, well below the melting temperature of steel.

It has not been found possible, so far, to derive a really reliable empirical method of determining the corresponding results for any gun ; but the numerical results already obtained suggest a short method, which, it is thought, will give an estimate of the total heat-loss, certainly accurate to within 20 per cent.

B.01. Heat Transfer from the Propellant Gases to the Gun Barrel

During the firing of a gun, heat is transferred from the propellant gases to the barrel wall, the breech face, and the base of the shot, by forced convection and by radiation. Some rough calculations showed that the heat transferred by radiation is very much less than that by forced convection, under conditions of velocity, density, etc., corresponding to mean values in an average gun. Near the back of the chamber, where the gas velocity is always small, the effect of radiation may be comparable with the effect of forced convection; but the total heat transferred to this region is relatively small, so the heat transfer by radiation has been completely neglected.

The relative gas velocity over the breech face and the base of the shot is small, and is, in fact, neglected in the model usually assumed for conditions inside a gun barrel. The convection of heat to these parts is consequently small also, and has been neglected. Therefore, in the following account, only forced convection of heat to the walls of the chamber and the bore is considered.

B.02. Assumptions

The heat transfer from the gases takes place through a thin boundary layer next to the barrel wall, and the mechanism of transfer depends largely on the Reynolds' number of the flow. Let

- x be distance along the barrel from the breech face,
- U_1 , the main-stream gas velocity,
- ρ , the gas density,
- μ , the gas viscosity.

In the numerical cases considered, the Reynolds' number, defined as $R_x = \rho U_1 x / \mu$, was found to lie in the range $10^5 - 10^{10}$, except very close to the breech face, and except during a very short time at the commencement of firing.

Initially, the boundary layer is presumably entirely laminar, but, at such high Reynolds' numbers, there must be a rapid transition to a turbulent boundary layer quite close to the rear of the chamber. It will therefore be sufficiently accurate to treat the boundary layer as entirely turbulent at all times and for all positions along the barrel.

The flow in the boundary layer is taken to be equivalent to that along a plane wall. This is a reasonable assumption if the boundary layer thickness is everywhere small compared with the diameter of the bore, and its validity can be verified *a posteriori* by the calculated boundary-layer thickness.

The corresponding problem of the heat transfer to a rocket casing during firing has been treated in a paper* which contains an account of the simplifying assumptions necessary to obtain a theoretical solution of the boundary-layer problem. The most important of these assumptions is that the gases are treated as incompressible. Actually, the main stream density varies both with position and time, and the large temperature gradient across the boundary layer implies a correspondingly large density gradient; but the problem appears to be intractable when these factors are taken into account, so they have been neglected.

B.03. The state of the propellant gases

As a simple model, the chamber and bore of a gun have been taken to form a right circular cylinder of uniform cross-section equal to the bore area. In consequence, the length of the chamber has been modified, so as to retain the true chamber volume.

* G. F. P. Trubridge, F. M. C. Goodspeed and D. M. Clemmow, *Theoretical investigations on the transfer of heat to rocket tubes*, A.C.1703/I.B.63.

The following notation is used throughout this Appendix :—

- x , distance along the barrel,
 $X(t)$, position of base of shot at time t ,
 both measured from the breech face ;
 U_1 , the main-stream gas velocity at position x and time t ;
 \bar{p} , the mean gas pressure at time t ,
 $\bar{\rho}$, the mean density,
 \bar{T}_g , the mean temperature,
 all calculated from the internal-ballistics equations ;
 p , the gas pressure at position x and time t ,
 ρ , the density,
 T_g , the temperature ;
 b , the co-volume of the gases,
 γ , the adiabatic constant,
 C , the charge mass,
 W , the shot mass.

The variations in velocity, pressure, density and temperature of the propellant gases along a gun barrel have been discussed in many papers,* and the following relations have been used :—

The gas velocity is proportional to the distance from the breech face, so,

$$U_1 = \frac{x}{X} \frac{dX}{dt} \quad \text{B,01}$$

and the variation in pressure along the barrel is given by,

$$\frac{p}{\bar{p}} = \frac{1 + \frac{1}{2} (C/W) [1 - x^2/X^2]}{1 + \frac{1}{3} (C/W)} \quad \text{B,02}$$

The density is related to the pressure by the equation,

$$p \left\{ \frac{1}{\rho} - b \right\}^\gamma = \bar{p} \left\{ \frac{1}{\bar{\rho}} - b \right\}^\gamma \quad \text{B,03}$$

which, together with B,02, gives the variation in density along the barrel.

Equation B,03 and the equation of state of the gases give the variation in temperature as

$$T_g/\bar{T}_g = (p/\bar{p})^{(\gamma-1)/\gamma}$$

This variation in T_g is comparatively small, and it is also incorrect initially, for T_g must then be constant along the barrel ; T_g has therefore been taken constant along the barrel at all times, that is,

$$T_g = \bar{T}_g \quad \text{B,04}$$

* E. P. Hicks and C. K. Thornhill, *Notes on the pressure distribution along a gun barrel*, A.C.1660/I.B.59/Gn.92. See also Chapter VII.

The same initial inconsistency applies also to the pressure and density variations, but B,02 and B,03 are used, since these variations are larger. The equation of state is never subsequently used, so the fact that the pressure, density and temperature are not quite consistent with it does not matter.

B.04. The velocity distribution across the boundary layer

Consider the two-dimensional flow of a viscous incompressible fluid along a plane wall.

Let

- x be distance measured along the wall,
- y , distance perpendicular to the wall,
- δ , the boundary layer thickness,
- U , the fluid velocity in the boundary layer along the x -axis,
- μ , the fluid viscosity,
- $\nu = \mu/\rho$, the kinematic viscosity,
- τ_0 , the skin friction at the wall.

For the case of steady uniform flow along an infinite plane wall, it can be shown† by dimensional analysis that the velocity distribution across the boundary layer is of the form,

$$U = v_* \varphi(\eta) \quad \text{B,05}$$

where

$$v_* = \sqrt{(\tau_0/\rho)} \quad \eta = v_* y/\nu$$

and φ is a function to be determined. From an analysis of Blasius' experimental results for flow in pipes, it has been deduced (D. III. page 137) that,

$$\varphi(\eta) = 8.74\eta^{1/7} \quad \text{B,06}$$

but this formula only holds for Reynolds' numbers up to about 10^5 . At higher Reynolds' numbers much better agreement with experiment is obtained with the theoretically-derived, logarithmic, velocity distribution. This can be written (D. III. page 150) in the form,

$$\varphi(\eta) = 2.495 \ln(1 + 8.93 \eta) \quad \text{B,07}$$

The equation of motion of the main stream is,

$$-\frac{1}{\rho} \frac{\partial p}{\partial x} = \frac{\partial U_1}{\partial t} + U_1 \frac{\partial U_1}{\partial x} \quad \text{B,08}$$

and hence the case of steady uniform flow corresponds to zero pressure gradient. When there is a pressure gradient, the boundary-layer velocity distribution may depend on further parameters involving the pressure gradient.

This fact was used by Buri to develop a theory of turbulent boundary layers for steady but non-uniform flows over the range of Reynolds' numbers in which Blasius' seventh-root law can be applied. Using this theory,‡ it can be shown that,

$$\frac{\tau_0}{\rho U_1^2} = 0.038 \left\{ \frac{U_1 x}{\nu} \right\}^{-1/5} \quad \text{B,09}$$

† *Aerodynamic theory*, Vol. III, Edited W. F. Durand, p. 134. Further references to this volume are denoted by D.III.

‡ *Modern developments in fluid dynamics*, Edited S. Goldstein, pp. 375 and 436. Further references to this book are denoted by G.

The skin friction can, however, in this case, be obtained directly from the boundary-layer momentum integral (see Section B.05) if the velocity distribution across the boundary layer is known. Assuming $U = 8.74 v_* \eta^{1/7}$, it is found that,

$$\frac{\tau_0}{\rho U_1^2} = 0.0396 \left\{ \frac{U_1 x}{\nu} \right\}^{-1/5} \quad \text{B,10}$$

and hence the assumed velocity distribution leads to a reasonably accurate value for the skin friction. For the flow in guns, U_1 is proportional to x , but the constant of proportionality varies with time. The additional problem of boundary-layer growth must therefore be considered. Though this cannot be done on Buri's theory, the boundary-layer momentum integral can be used, if the form of the velocity distribution is known.

It is therefore assumed that the velocity distribution across the boundary layer is of the same form as that for steady, uniform flow along a plane wall.

B.05. The boundary-layer momentum integral

The boundary-layer momentum integral for turbulent flow along a plane wall is, (G. page 133),

$$\tau_0 = \rho \frac{\partial}{\partial x} \int_0^\delta (U_1 - U) U dy + \rho \frac{\partial}{\partial t} \int_0^\delta (U_1 - U) dy + \rho \frac{\partial U_1}{\partial x} \int_0^\delta (U_1 - U) dy \quad \text{B,11}$$

$$\text{Let} \quad U = v_* \varphi(\eta) \quad \text{B,12}$$

$$\eta_1 = v_* \delta / \nu \quad \text{B,13}$$

$$\text{and then} \quad U_1 = v_* \varphi(\eta_1) \quad \text{B,14}$$

After some reduction the momentum integral becomes

$$\begin{aligned} \frac{U_1^2}{\nu} = & \frac{\partial U_1}{\partial x} \varphi(\eta_1) \left\{ \eta_1 \varphi^2(\eta_1) - \int_0^{\eta_1} \varphi^2(\eta) d\eta \right\} \\ & + U_1 \frac{d\varphi(\eta_1)}{d\eta_1} \frac{\partial \eta_1}{\partial x} \int_0^{\eta_1} \varphi^2(\eta) d\eta \\ & + \eta_1 \varphi^2(\eta_1) \frac{d\varphi(\eta_1)}{d\eta_1} \frac{\partial \eta_1}{\partial t} \end{aligned} \quad \text{B,15}$$

If φ and U_1 are known functions, this is an equation to determine the parameter η_1 .

At the high Reynolds' numbers occurring in the gas flow down a gun barrel, it would be most accurate to use the logarithmic velocity distribution (equation B,07), but the resulting equation for η_1 has no simple solution. Consider, however, the velocity distribution given by,

$$\varphi(\eta) = a\eta^{1/n} \quad \text{B,16}$$

This generalization of the Blasius power law is suggested by the statement (G. page 340) that to maintain agreement with experiment at Reynolds' numbers greater than 10^5 , the index $1/7$ in the power law must be taken as $1/8$, $1/9$, etc., successively. The relevant values of the constants a and n are derived in Section B.07.

Using B,16 and substituting $U_1 = \frac{x}{X} \frac{dX}{dt}$, the momentum integral becomes

$$\frac{1}{v} \frac{x^2}{X^2} \left(\frac{dX}{dt} \right)^2 = \frac{2a^3}{n+2} \eta_1^{1+3/n} \frac{1}{X} \frac{dX}{dt} + \frac{a^3}{n+2} \eta_1^{3/n} \frac{x}{X} \frac{dX}{dt} \frac{\partial \eta_1}{\partial x} + \frac{a^3}{n} \eta_1^{3/n} \frac{\partial \eta_1}{\partial t} \quad \text{B,17}$$

The boundary-layer thickness is initially zero, and it remains zero at the breech face. The boundary conditions on η_1 are therefore

$$t = 0, \eta_1 = 0 \text{ for all } x \quad \text{B,18(a)}$$

$$x = 0, \eta_1 = 0 \text{ for all } t \quad \text{B,18(b)}$$

and the corresponding solution of equation B,17 is,

$$\eta_1^{\frac{n+3}{n}} = \frac{n+3}{va^3} x^2 X^{-\frac{4n+6}{n+2}}(t) \int_0^t X^{\frac{2n+2}{n+2}}(\tau) \left(\frac{dX}{d\tau} \right)^2 d\tau \quad \text{B,19}$$

In numerical calculations it was convenient to use the following non-dimensional functions:—

$$K(t) = \frac{(n+3) \int_0^t X^{\frac{2n+2}{n+2}}(\tau) \left(\frac{dX}{d\tau} \right)^2 d\tau}{X^{\frac{3n+4}{n+2}}(t) \frac{dX}{dt}} \quad \text{B,20}$$

and the Reynolds' number,

$$R_x = \frac{U_1 x}{v} \quad \text{B,21}$$

Then,

$$\eta_1^{1+3/n} = K(t) R_x / a^3 \quad \text{B,22}$$

and the surface skin friction is given by,

$$\tau_0 = \rho U_1^2 / a^2 \eta_1^{2/n} \quad \text{B,23}$$

B.06. The heat transmission coefficient

Consider the rate of heat transfer from the propellant gases to the barrel wall.

Let

c_p be the specific heat of the gases at constant pressure,

k_g , the thermal conductivity of the gases,

$\sigma = \mu c_p / k_g$, the Prandtl number,

h , the heat transmission coefficient, which is defined as the heat transferred from the gases to unit area of the wall, in unit time, at unit temperature-difference between the main gas stream and the wall.

Reynolds' analogy (G. page 649), between the transfer of momentum and heat in turbulent flow, is assumed to hold, although the conditions for its validity are not strictly satisfied in the present application. An extension of this analogy, when the Prandtl number σ is not equal to unity, has been derived by von Kármán (G. page 657). In the present notation, his result can be written in the form,

$$\frac{\rho c_p U_1}{h} = \frac{\rho U_1^2}{\tau_0} + 5 \left(\frac{\rho U_1^2}{\tau_0} \right)^{\dagger} \left\{ (\sigma - 1) + \ln [1 + 0.83 (\sigma - 1)] \right\} \quad \text{B,24}$$

But

$$\rho U_1^2 / \tau_0 = a^2 \eta_1^{2/n}$$

and therefore,

$$h = \frac{\rho c_p U_1}{a \eta_1^{1/n} \left[a \eta_1^{1/n} + 5 \{ (\sigma - 1) + \ln [1 + 0.83 (\sigma - 1)] \} \right]} \quad \text{B,25}$$

B.07. Numerical values of the constants a and n

The assumption, that the boundary-layer velocity distribution is of the same form in steady uniform flow as in the type of accelerated non-uniform flow occurring in guns (Section B.04), has been used to obtain numerical values of a and n .

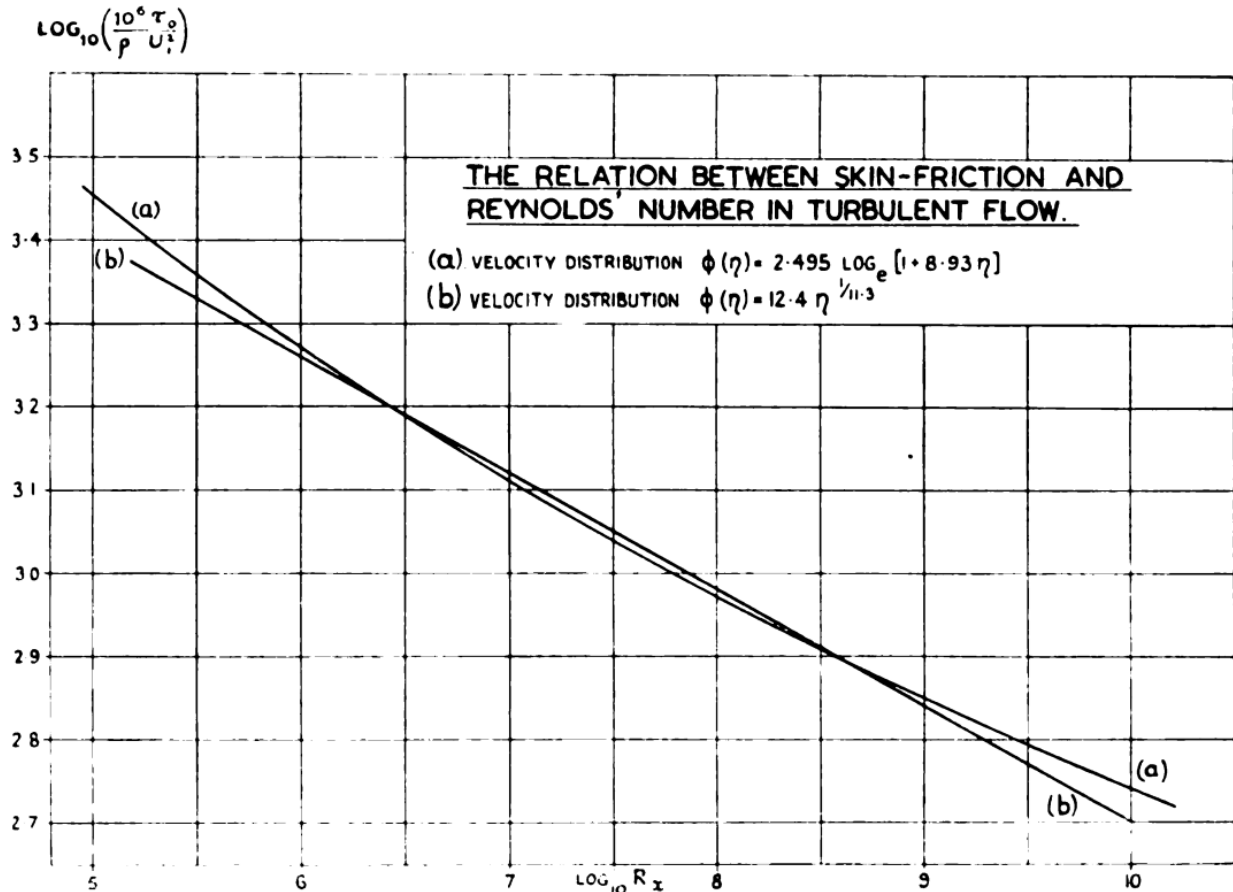

Figure B.1

For steady uniform flow, the boundary-layer momentum integral (equation B,15) reduces to

$$\frac{dx}{d\eta_1} = \frac{v}{U_1} \frac{d\varphi(\eta_1)}{d\eta_1} \int_0^{\eta_1} \varphi^2(\eta) d\eta \quad \text{B,26}$$

This can be integrated immediately for the two distributions :—

- (1) the power law, $\varphi(\eta) = a\eta^{1/n}$, and
- (2) the logarithmic law, $\varphi(\eta) = 2.495 \ln \{ 1 + 8.93 \eta \}$ (see D. III pages 147-150).

In each case a relation is derived between the skin-friction coefficient $\tau_0/\rho U_1^2$ and the Reynolds' number R_x .

The calculated Reynolds' numbers lie in the range $10^5 - 10^{10}$ for almost the whole range of position and time. The values of a and n were therefore chosen so that the skin friction derived by the power law should be as near as possible to that arising from the logarithmic law, over this range of Reynolds' numbers.

The values,

$$a = 12.4 \quad n = 11.3 \quad \text{B,27}$$

give a skin friction τ_0 in error by less than 3 per cent. over the range $R_x = 10^6 - 10^9$, but the error increases outside this range. These values have been adopted throughout the subsequent numerical work. Figure B.1 shows $\log(10^6 \tau_0/\rho U_1^2)$ plotted against $\log R_x$, for the logarithmic law, and for the power law using the fitted values of a and n .

B.08. The boundary-layer thickness

From the analysis of Section B.05, the boundary layer thickness δ is obtained as

$$\delta = x K^{\frac{n+1}{n+3}}(t) / a^{\frac{2n}{n+3}} R_x^{\frac{2}{n+3}} \quad \text{B,28}$$

The function $K(t)$ is very stable for all the cases evaluated ; it is initially zero, increases rapidly towards an asymptotic value, and over most of the shot travel lies between the values 4 and 5, never exceeding 5. These results are probably true in general.

If the upper value 5 is taken for $K(t)$, and the rather low value 10^8 for the Reynolds' number at the muzzle, then,

$$\delta/d = 0.0057 x/d \quad \text{B,29}$$

where d is the bore diameter. For a rather long gun of length 100 calibres, equation B,29 gives a boundary-layer thickness at the muzzle about equal to the bore radius, but such extreme conditions would not be realized in practice. In actual numerical cases, the calculated boundary-layer thickness has never exceeded one-half the bore radius, even at the muzzle.

In general, then, the flow in a gun barrel is entirely *inlet length flow*, and it is reasonable to regard it as equivalent to flow along a plane wall as far as the boundary layer is concerned.

B.09. Calculation of the heat-transmission coefficient

The determination of the physical properties of the propellant gases requires first a knowledge of their composition, and this was calculated, for the propellants considered, from information given in a report by H. H. M. Pike.*

The thermal conductivity and viscosity of the constituent gases are obtainable at low pressures and temperatures from various sources.† It has been assumed that they are independent of pressure, and obey Sutherland's law† for changes in temperature. Further, in a gaseous mixture, thermal conductivities and viscosities have been assumed additive according to the gram-molecular proportions of each constituent. Specific heats at constant pressure are obtainable for gases at low pressure,‡ and these values have been used. In a gaseous mixture, the specific heats have been assumed additive in proportion to the mass of each component.

* H. H. M. Pike, *Thermochemical data for the products of propellant explosions*, A.C.1862/I.B.78.

† International Critical Tables.

Fishenden and Saunders, *Calculation of heat transmission*.

W. H. McAdams, *Heat transmission*.

Schack, Goldschmidt and Partridge, *Industrial heat transfer*.

‡ Pike, *loc. cit.*

For the two propellants considered, σ was calculated to lie between 0.4 and 0.6 in the relevant temperature range, whilst for each constituent of the gaseous mixture, σ is much higher, at least 0.7. This anomaly arises from the relatively-large thermal conductivity of hydrogen, and raises doubts about this method of deriving σ .

But the formula for the heat-transmission coefficient can be written

$$h = \frac{\rho c_p U_1}{a \eta_i^{1/n} [a \eta_i^{1/n} - F(\sigma)]} \tag{B,30}$$

where

$$F(\sigma) = -5 \{ (\sigma - 1) + \ln [1 + 0.83 (\sigma - 1)] \} \tag{B,31}$$

as compared with,

$$h = \rho c_p U_1 / a^2 \eta_i^{2/n} \tag{B,32}$$

on the simple Reynolds' analogy (G. page 650).

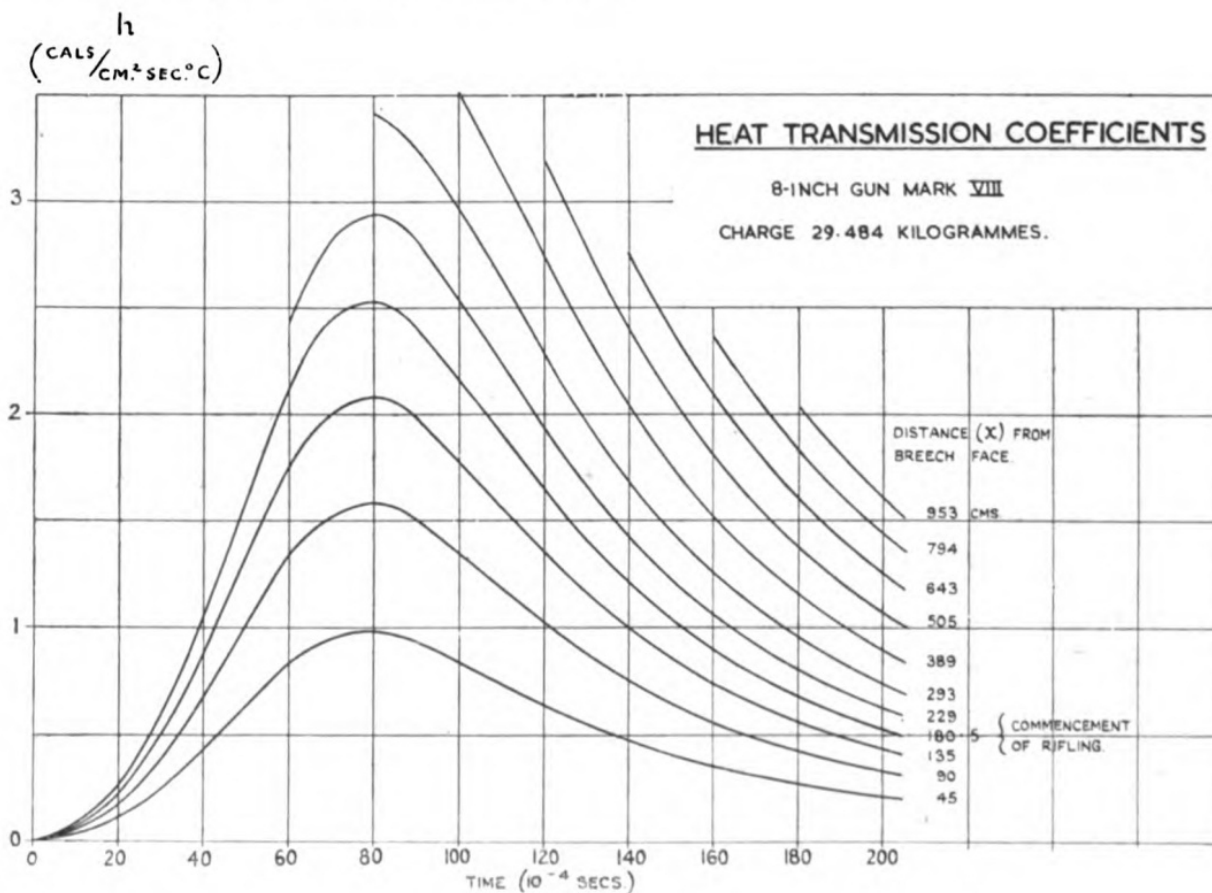

Fig. B.2

The thermal conductivity only occurs through σ in the correcting term $F(\sigma)$ which is fairly small compared with $a \eta_i^{1/n}$. Thus any possible error in σ is not of major importance, so in calculating h , a mean value has been taken for $F(\sigma)$, namely 5.3 for Cordite SC and 4.65 for propellant W. In practice, the correcting term $F(\sigma)$ increased h by about 10–20 per cent.

The values of μ , c_p , etc., have been taken equal to their local values at the main-stream gas temperature, in calculating h . It would be more accurate to use values appropriate to

the mean boundary-layer temperature, but this would greatly increase the computation, since the mean temperature is unknown until the actual wall temperature has been calculated ; moreover, such temperature corrections would have little effect on the numerical values of h . Figure B.2 shows the heat transmission coefficients, calculated at different positions along the barrel, in a typical case.

Since the heat transfer has been investigated on the implicit assumption that the barrel wall is smooth, a few remarks on wall roughness are appropriate. The rifling in the bore approximates to a series of shallow, longitudinal grooves, and it is not considered that this will constitute a rough surface in the hydrodynamical sense ; but the effects of erosion suggest that it may be necessary to consider the inside of an old gun barrel as a rough surface. The theoretical problem would then involve a knowledge of its "equivalent sand-roughness coefficient" (G. page 380), and this is primarily a matter for experiment.

B.10. Conduction of Heat through the Gun Barrel

The problem requires a solution of the equation of heat conduction, satisfying the appropriate boundary conditions. One of these is that the barrel temperature is initially the same everywhere. In the previous section, the heat-transmission coefficient at the inner surface of the barrel has been determined over the range of time of firing, and from this the boundary condition at the inner surface can be derived.

Numerical calculations have shown that the penetration of heat into a gun barrel, during the firing of a single shot in a cold gun, is very small (of order one millimetre), and this makes possible two approximations :—

- (a) The inner surface of the barrel may be treated as part of a plane wall, and heat flow along the length of the barrel may be neglected.
- (b) The barrel may be considered as having no external boundary. The boundary condition at the outer wall is then replaced by the condition that the barrel temperature tends to the initial (atmospheric) temperature at great distances from the inner wall.

B.11. Solution of the heat conduction equation

Consider the conduction of heat inside a plane wall.

Let

- k be the thermal conductivity of the barrel,
- ρ_1 , the density,
- s , the specific heat per unit mass,
- all of which vary with temperature ;
- z , the distance measured perpendicular to the wall ;
- $T(z, t)$ the barrel temperature,
- $T_g(t)$ the temperature of the propellant gases,
- $h(t)$, the heat transmission coefficient.

The equation of heat conduction is then,

$$\rho_1 s \frac{\partial T}{\partial t} = \frac{\partial}{\partial z} \left(k \frac{\partial T}{\partial z} \right) \quad \text{B,33}$$

and the boundary conditions are,

$$t = 0, \quad T = 0 \quad \text{for all } z \quad \text{B,34(a)}$$

$$z = 0, \quad -k \frac{\partial T}{\partial z} = h(T_g - T) \quad \text{B,34(b)}$$

$$z \rightarrow \infty, \quad T \rightarrow 0 \quad \text{B,34(c)}$$

k and $\rho_1 s$ have been replaced by mean constant values over the appropriate temperature range ; this should not introduce any serious error. Dividing up the time interval over which heat transfer takes place into a number of equal small intervals δt , equation B,33 may be replaced approximately during one of these intervals by

$$\frac{T_1(z) - T_0(z)}{\delta t} = \frac{1}{2} A \frac{\partial^2}{\partial z^2} \{ T_0(z) + T_1(z) \}$$

where $T_0(z)$ is the temperature-space distribution at the beginning of the interval, $T_1(z)$ is the temperature-space distribution at the end of the interval, and $A = k/\rho_1 s$, the mean constant thermometric conductivity.

Writing $q^2 = 2/A\delta t$, this reduces to

$$\frac{\partial^2}{\partial z^2} \{ T_0 + T_1 \} = q^2 \{ T_0 + T_1 \} - 2q^2 T_0 \quad \text{B,35}$$

The boundary conditions become now

(a) $T_0(z)$ is a known function ;

$$(b) \quad z = 0, \quad -k \frac{\partial T_0}{\partial z} = h_0(T_{g_0} - T_0)$$

$$z \rightarrow \infty, \quad T_0 \rightarrow 0$$

where h_0 and T_{g_0} refer to the beginning of the interval δt ; and

$$(c) \quad z = 0, \quad -k \frac{\partial T_1}{\partial z} = h_1(T_{g_1} - T_1)$$

$$z \rightarrow \infty, \quad T_1 \rightarrow 0$$

where h_1 and T_{g_1} refer to the end of the interval. The conditions (b) and (c) combine into the more useful condition,

$$z = 0, \quad \frac{\partial}{\partial z} (T_0 + T_1) = -\frac{h_0 T_{g_0} + h_1 T_{g_1}}{k} + \frac{h_0 T_0 + h_1 T_1}{k} \quad \text{B,36(a)}$$

$$z \rightarrow \infty, \quad (T_0 + T_1) \rightarrow 0 \quad \text{B,36(b)}$$

The solution of equation B,35 with these boundary conditions is,

$$T_0 + T_1 = qe^{-qx} \int_0^x e^{qu} T_0(u) du + qe^{qx} \int_x^\infty e^{-qu} T_0(u) du \\ + e^{-qx} \left\{ \frac{h_0 T_{g_0} + h_1 T_{g_1}}{h_1 + kq} + \frac{h_1 - h_0}{h_1 + kq} T_0(0) - \frac{h_1 - kq}{h_1 + kq} q \int_0^\infty e^{-qu} T_0(u) du \right\} \quad \text{B,37}$$

which determines $T_1(z)$ in terms of $T_0(z)$ and the conditions governing heat transfer during the interval.

The practical usefulness of this solution lies in the fact that the integrals can be evaluated analytically. In fact, the temperature distribution at the beginning of interval number $(n + 2)$ is obtained in the form

$$T_0(z) = e^{-qx} \left\{ a_0 + a_1(2qx) + \dots + a_n \frac{(2qx)^n}{n!} \right\} \quad \text{B,38}$$

and the temperature distribution at the end of that interval is then derived from B,37 as

$$T_1(z) = e^{-qx} \left\{ b_0 + b_1(2qx) + \dots + b_{n+1} \frac{(2qx)^{n+1}}{(n+1)!} \right\} \quad \text{B,39}$$

where

$$b_0 = \frac{h_0 T_{g_0} + h_1 T_{g_1}}{h_1 + kq} - \frac{h_0 + kq}{h_1 + kq} a_0 + \frac{kq}{h_1 + kq} [a_0 + a_1 + \dots + a_n] \quad \text{B,40 (a)}$$

$$b_1 = -a_1 + \frac{1}{2} [a_0 + a_1 + \dots + a_n] \quad \text{B,40 (b)}$$

$$b_r = -a_r + \frac{1}{2} [a_{r-1} + a_r + \dots + a_n] \quad \text{B,40 (c)}$$

$$b_n = -a_n + \frac{1}{2} [a_{n-1} + a_n] \quad \text{B,40 (d)}$$

$$b_{n+1} = \frac{1}{2} a_n \quad \text{B,40 (e)}$$

Starting from the initial temperature $T_0(z) = 0$, these recurrence relations form the basis of a simple method of calculating the temperature distribution at the end of any subsequent interval.

B.12. The effect of an initial discontinuity in the boundary conditions

The solution derived in the last paragraph assumes implicitly that the initial value of $h(t)$ is always zero, for otherwise the boundary conditions B,36 cannot be satisfied at the beginning of the first interval. In such circumstances it is not sufficiently accurate to replace the partial differential equation of heat conduction by the approximate difference equation B,35 over the first interval. In practice the solution gives an oscillatory temperature-distribution when h is not initially zero. This difficulty is overcome by fitting an analytical solution of the exact partial differential equation to the first arc.

For an initial, short time-interval, during which h and T_g can be taken to have mean constant values $\frac{1}{2}(h_0 + h_1)$ and $\frac{1}{2}(T_{g_0} + T_{g_1})$ respectively, the solution of the heat-conduction equation is*

$$T(z, \delta t) = \frac{T_{g_0} + T_{g_1}}{2} \left\{ \operatorname{erfc} \left[\frac{qz}{2\sqrt{2}} \right] - \exp \left[\frac{(h_0 + h_1)^2}{2k^2 q^2} + \frac{(h_0 + h_1)z}{2k} \right] \operatorname{erfc} \left[\frac{h_0 + h_1}{kq\sqrt{2}} + \frac{qz}{2\sqrt{2}} \right] \right\} \quad \text{B,41}$$

* H. Jeffreys, *Operational methods in Mathematical Physics*. Cambridge Tract No. 23, p. 69.

where the complement of the error function is defined as,

$$\operatorname{erfc}(w) = 1 - \operatorname{erf}(w) = \frac{2}{\sqrt{\pi}} \int_w^{\infty} e^{-u^2} du \quad \text{B,42}$$

A series of the type B,38 can be fitted to this temperature distribution to provide a starting point for the small-arc method. In practice, only the first two terms of the series were used. The expression,

$$e^{-qx} [a_0 + a_1(2qx)] \quad \text{B,43 (a)}$$

with $a_0 = T(0, \delta t) \quad \text{B,43 (b)}$

and $a_1 = \frac{h_1 + kq}{2kq} a_0 - \frac{h_1 T_{g_1}}{2kq} \quad \text{B,43 (c)}$

gives the correct surface temperature and satisfies the boundary conditions B,36. Moreover, in a numerical case, it was found to agree quite well with the temperature distribution B,41 and when used as a starting point for the small-arc method, the resulting temperature distributions were practically non-oscillatory.

B.13. The numerical calculation of temperatures

The temperature distributions in the barrel can be calculated directly from the finite series derived in the preceding paragraphs, but, in determining heat losses, the complete temperature distributions are not required. For the rate at which the gases lose heat to the barrel is $h(T_g - T)$, where T here refers to the temperature at the inner surface, which is given simply by the first coefficient a_0 (or b_0) of the recurrence relations.

In calculating surface temperatures, the relevant time range was divided, as far as possible, into about ten intervals. This, it was thought, would give as much accuracy as is needed in the application of the results.

For each gun, temperatures were calculated at several cross-sections of the barrel. In general, three positions were chosen in the chamber and about six along the bore, one of which was always at the commencement of rifling. At positions along the bore, it was assumed that no heat transfer takes place until the base of the shot passes, at which instant the heat-transmission coefficient suddenly attains the finite value calculated as in Section B.09.

B.14. The heat loss to the barrel

Having determined the surface temperature of the barrel at different positions along its length, it is now possible to derive the heat loss completely by integration.

Let x_0 be the initial position of the base of the shot,
 x_m , the position of the muzzle,
 $X(t)$, the x -co-ordinate of the base of the shot at time t ,
 t_x , the time when the base of the shot is at position x ,
 t_m , the time of ejection of the shot.

Considering only heat losses up to the time of ejection of the shot, the following functions can now be defined.

(a) $H_1'(x)$ is the total heat-loss per unit area at a fixed position (x) along the barrel, so

$$H_1'(x) = \int_{t_x}^{t_m} h(T_g - T) dt \quad \text{B,44}$$

(b) $H_2'(t)$ is the total heat-loss per unit time at a fixed time (t) before ejection, so

$$H_2'(t) = \pi d \int_0^{x(t)} h(T_g - T) dx \quad \text{B,45}$$

d being the diameter of the bore.

(c) The total heat-loss up to time t is thus,

$$H_2(t) = \int_0^t H_2'(t) dt = \int_0^t \pi d \int_0^x h(T_g - T) dx dt \quad \text{B,46}$$

(d) The total heat-loss up to the time of ejection (t_m) is then,

$$H = H_2(t_m) = \int_0^{t_m} \pi d \int_0^x h(T_g - T) dx dt \quad \text{B,47}$$

or alternatively, from B,44

$$H = \pi d H_1(x_m) = \pi d \int_0^{x_m} \int_{t_x}^{t_m} h(T_g - T) dt dx \quad \text{B,48}$$

Numerically, these integrals can all be determined, to a sufficient degree of accuracy, using Simpson's rule.

B.15. Numerical Applications

Complete solutions of the equations of internal ballistics have been obtained on the Bush Differential Analyser at Cambridge, for the cases shown in the following table :—

| Case | Gun | Shot weight (kgm.) | Propellant | Charge weight (kgm.) | Shot-start pressure (kgm./cm. ²) | Maximum chamber pressure (kgm./cm. ²) | Muzzle velocity (cm./sec.) |
|------|-------------------|--------------------|------------|----------------------|--|---|----------------------------|
| A(a) | Two-pounder model | 1.0 | SC. | 0.72 | 630 | 4720 | 103,900 |
| A(b) | | | slotted | | | | 118,300 |
| A(c) | | | tube | | | | 127,350 |
| B | 25-pounder | 11.83 | W.057 | 0.7938 | 570 | 2389 | 46,650 |
| C(a) | 8-inch, Mark VIII | 119.51 | SC.205 | 29.484 | 290 | 3393 | 84,750 |
| C(b) | | | SC.205 | 24.948 | 290 | 2459 | 75,800 |
| C(c) | | | SC.150 | 20.412 | 350 | 2438 | 71,750 |
| C(d) | | | SC.103 | 13.608 | 440 | 1836 | 59,550 |

The three muzzle velocities for the two-pounder gun are for three different barrel lengths.

The total energy released by the burning of one gram of propellant has been taken to be the function $(E_0^{T_0} - E_0^{300})$ given in Pike's report. This is the energy difference between the resulting gaseous products at the uncooled burning temperature, and the same gases at 300°K. It is not strictly the actual energy made available by the combustion of the propellant, but it forms a reasonable standard with which to compare the heat energy lost to the barrel.

B.16. Numerical results

The following table shows the comparison between the heat-loss figures for the three guns :—

| Case | Gun | Propellant | C/W | Shot travel to muzzle $(x_m - x_0)$ (calibres) | Equivalent chamber length (calibres) | Total heat-loss H (calories) | Total heat-loss H (per cent. of total energy) | K.E. of shot at muzzle (per cent. of total energy) |
|------|-------------------|------------|--------|--|--------------------------------------|------------------------------|---|--|
| A(a) | Two-pounder model | SC. | 0.7200 | 36.67 | 22.69 | 29,100 | 4.7 | 20.7 |
| A(b) | | slotted | 0.7200 | 55.01 | 22.69 | 40,250 | 6.5 | 26.9 |
| A(c) | | tube | 0.7200 | 73.32 | 22.69 | 50,500 | 8.1 | 31.1 |
| B | 25-pounder | W.057 | 0.0671 | 22.06 | 4.47 | 33,700 | 4.6 | 41.8 |
| C(a) | 8-inch, Mark VIII | SC.205 | 0.2467 | 43.32 | 8.80 | 1,192,000 | 4.7 | 40.3 |

DEVELOPMENT OF HEAT LOSS WITH SHOT TRAVEL.

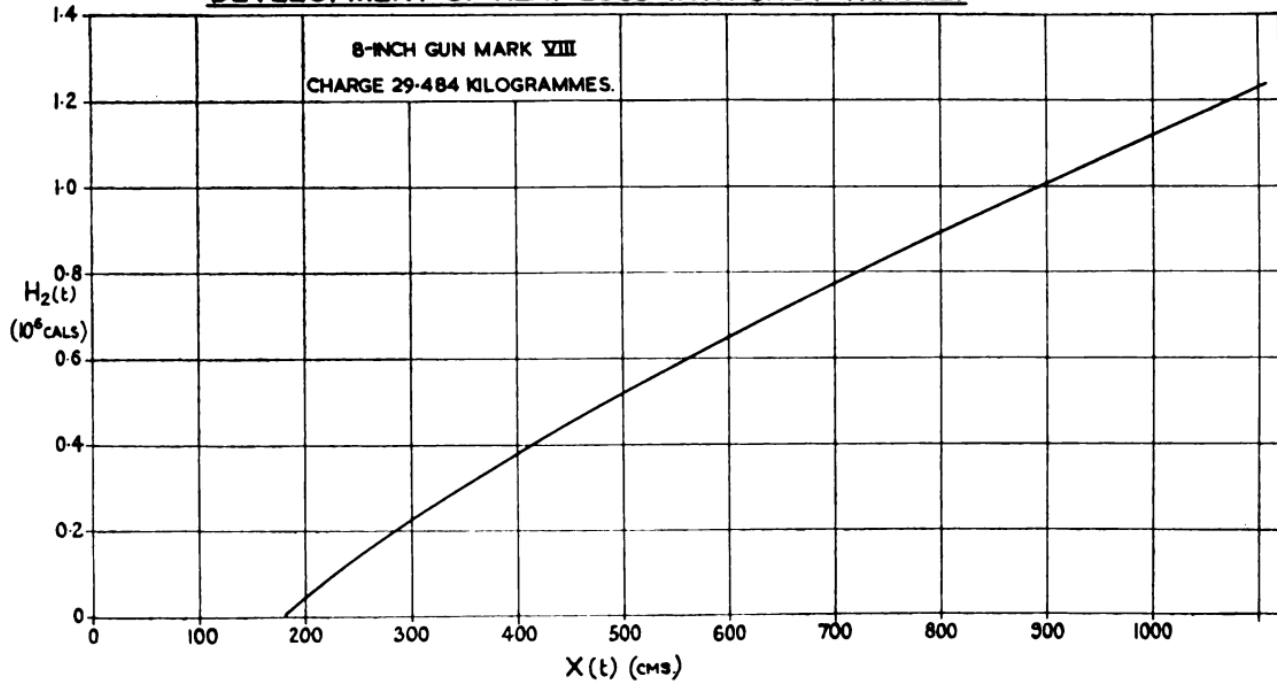

Fig. B.3

Figure B.3 shows the function $H_2(t)$ plotted against the shot-travel co-ordinate $X(t)$, and Figure B.4 shows the function $H_1'(x)$ plotted against distance x from the rear of the chamber, both for the case C(a), that of the 8-inch gun, Mark VIII, with charge weight 29.484 kgm. These curves may be regarded as typical, for their general shape is maintained in all the other

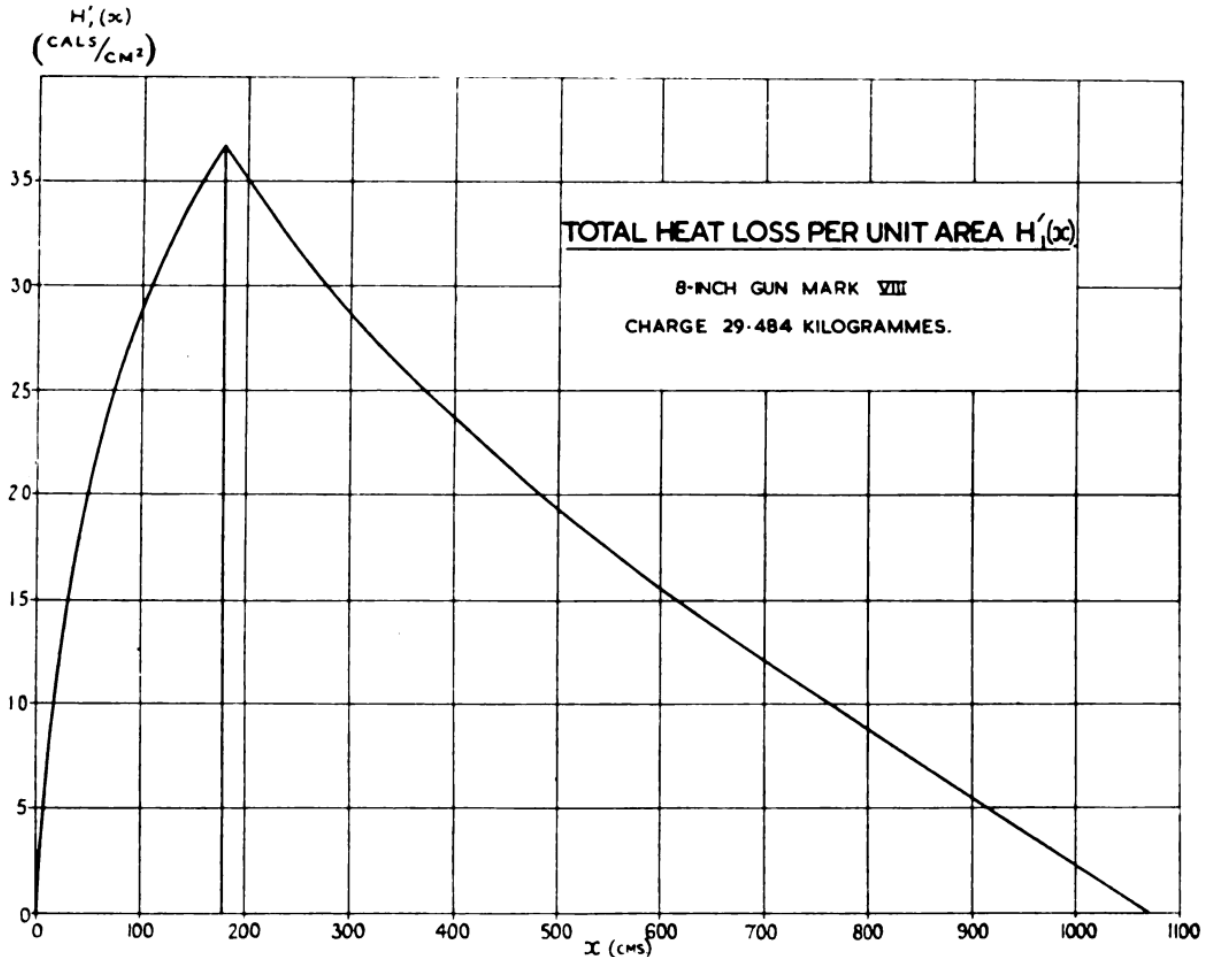

Fig. B.4

numerical cases evaluated. Figure B.3 demonstrates that the total heat loss up to any given time t is roughly proportional to the shot travel (*cf.* also, numerical figures in the above table for A(a), (b) and (c)). Figure B.4 demonstrates that the total heat loss per unit area at any cross-section follows roughly a triangular distribution along the barrel, being approximately zero at the rear of the chamber and at the muzzle, and having its maximum value, the apex, at the commencement of rifling.

It is not possible to draw any general conclusions from the figures in the above table, since the variables, namely propellant, charge/shot-weight ratio, and relative dimensions of the guns, vary considerably from case to case. It is significant, however, that the percentage heat-loss lies in the limited range 4—9 per cent. for all these cases, and the outstanding omission, the combination of low C/W and long barrel, is not of practical importance, except for small-arms.

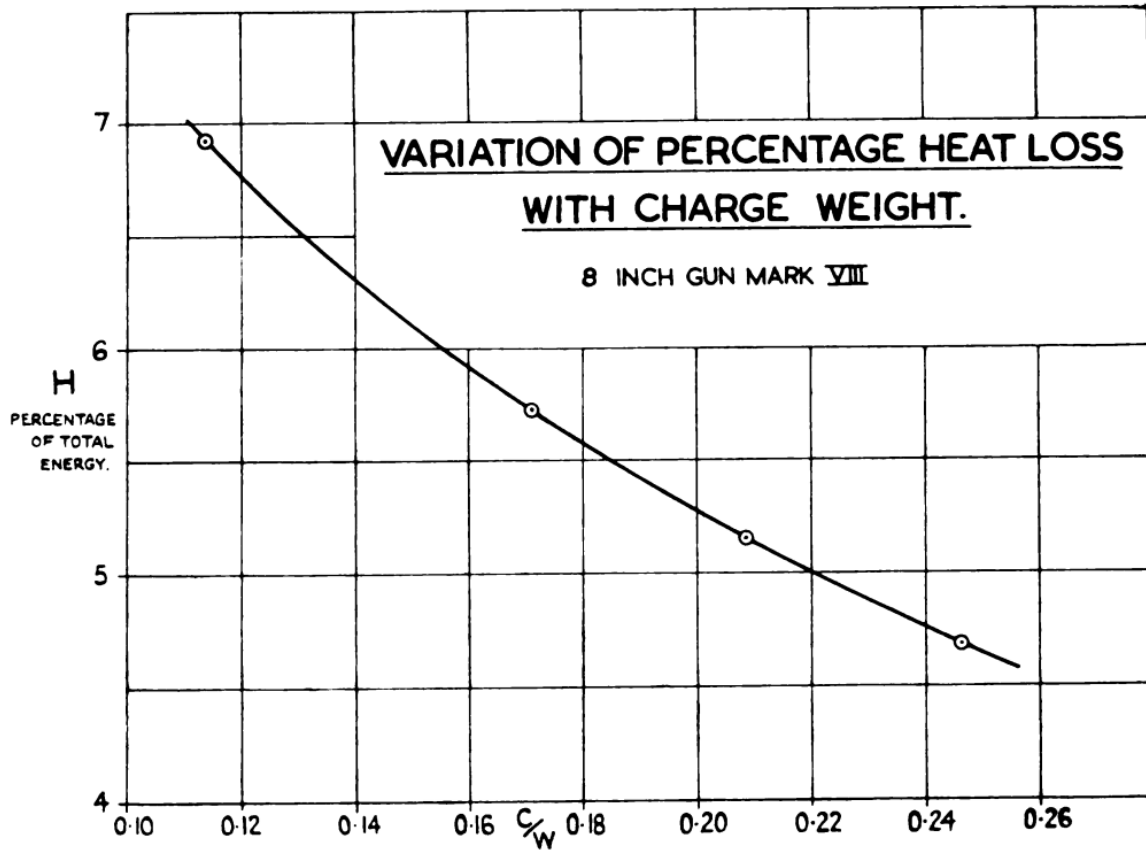
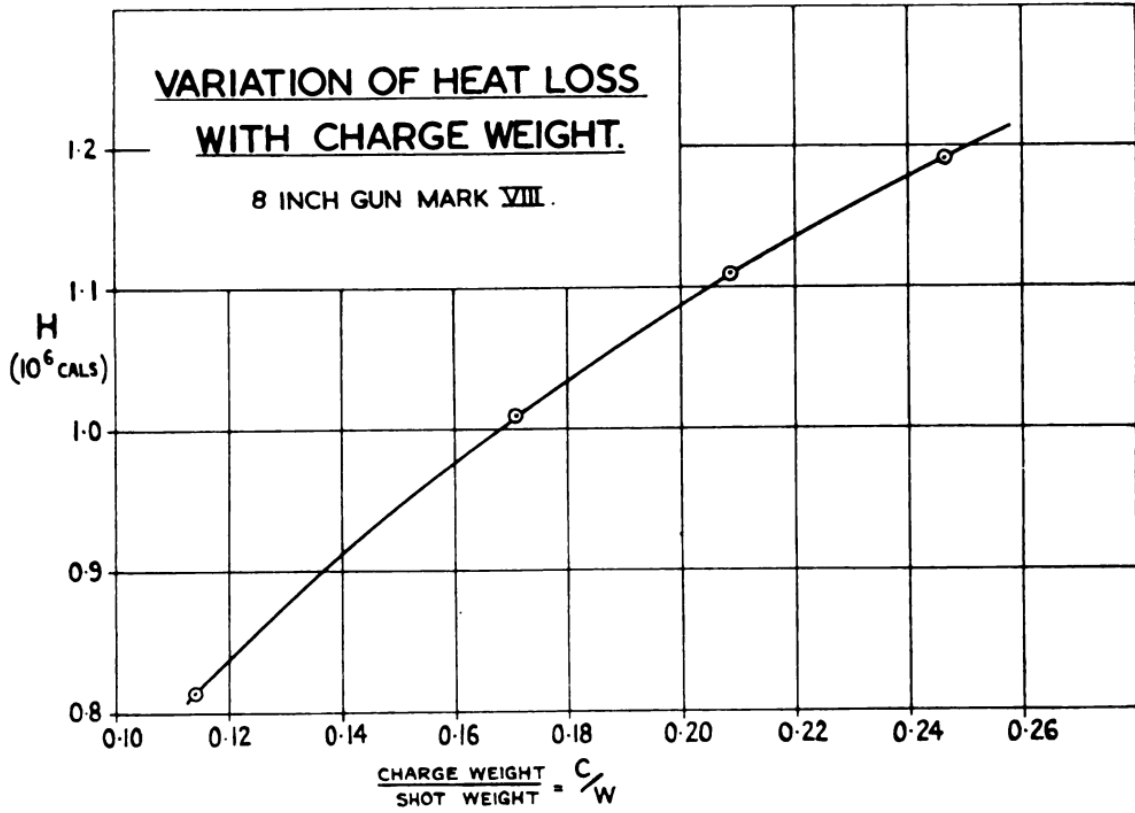

Fig. B.5 and B.6

The next table shows similar heat-loss figures for the 8-inch gun, Mark VIII, with four different values of the charge/shot-weight ratio C/W .

| Case | Charge weight (kgm.) | C/W | Total heat-loss H (calories) | Total heat-loss H (per cent. of total energy) | K.E. of shot at muzzle (per cent. of total energy) |
|------|----------------------|--------|--------------------------------|---|--|
| C(a) | 29.484 | 0.2467 | 1,192,000 | 4.68 | 40.3 |
| C(b) | 24.948 | 0.2088 | 1,110,000 | 5.16 | 38.1 |
| C(c) | 20.412 | 0.1708 | 1,009,000 | 5.73 | 41.7 |
| C(d) | 13.608 | 0.1139 | 813,000 | 6.92 | 43.0 |

These results are shown graphically in Figures B.5 and B.6. In Figure B.5 the actual heat-loss H is plotted as an increasing function of C/W , and in Figure B.6, the percentage heat-loss is plotted as a decreasing function of C/W . These are both significant results, and the second relation (Figure B.6), suggests that the heat loss to the barrel becomes relatively more important as the charge/shot-weight ratio is decreased.

B.17. Empirical formulae

The determination of the total heat-loss has involved the complete solution of the heat-transmission problem at several cross-sections of the chamber and the bore. So far it has not been found possible, from the numerical cases treated, to derive an empirical formula which will give the same result to a good degree of accuracy, without so much computation. If, however, in Figure B.4, the space distribution of heat-loss were exactly triangular, the total heat-loss H would be obtained as,

$$H = \frac{1}{2} \pi dx_m H_1'(x_0) \quad \text{B,49}$$

This value of H differs by 0—15 per cent. from the actual calculated values, and except for the two-pounder gun, it gives an over-estimate. The larger deviations from the calculated H occur when C/W is small, but, in general, the deviation has not been adequately correlated with variations in data from case to case. Remembering, however, that the heat-loss itself is only of order 5 per cent. of the total energy involved, this estimate of H gives a relatively quick and useful result.

From the figures given in the last table it appears that, for this particular gun, H is very nearly proportional to $\sqrt{(C/W)}$; the ratio $H/\sqrt{(C/W)}$ varies by less than 2 per cent. over

the range of values 0.1—0.25 of C/W .* If this result is confirmed for other guns, it provides a ready method of extending any evaluation of heat loss to cover other values of C/W .

The most useful approximation obtained from the numerical results is that the heat loss up to any time t is roughly proportional to the shot travel. This is illustrated in Figure B.3, and similar curves were obtained in all the other cases evaluated. If the heat loss were taken as strictly proportional to the shot travel, it would be comparatively simple to revise the equations of internal ballistics to allow for heat losses to the barrel.

B.18. Surface temperatures and heat penetration into the barrel

The temperatures attained by different parts of a gun barrel are of interest in the problem of gun erosion, and a selection of the many temperature distributions, obtained in the course of this investigation, is given here.

The following table gives, for the three different guns, the surface temperature of the barrel at the commencement of rifling (x_0), at various times up to ejection :—

Surface temperatures at commencement of rifling in °C.

| t (millisec.) | Two- pounder model | 25- pounder | 8-inch gun, Mark VIII | | | |
|--------------------|--------------------------|----------------|-----------------------|------|------|------|
| | A(c) | B | C(a) | C(b) | C(c) | C(d) |
| 0 | 15 | 15 | 15 | 15 | 15 | 15 |
| 1 | 311 | 148 | — | — | — | — |
| 2 | 939 | 423 | 90 | 72 | 88 | 96 |
| 3 | 1158 | 566 | — | — | — | — |
| 4 | 1052 | 561 | 359 | 243 | 297 | 286 |
| 5 | 920 | 512 | — | — | — | — |
| 6 | — | 463 | 749 | 518 | 590 | 510 |
| 7 | — | 422 | — | — | — | — |
| 8 | — | — | 1012 | 768 | 818 | 669 |
| 10 | — | — | 1073 | 896 | 898 | 723 |
| 12 | — | — | 1037 | 920 | 886 | 712 |
| 16 | — | — | 901 | 846 | 784 | 638 |
| 20 | — | — | 781 | 750 | 686 | 565 |

The next table shows the variation in surface temperature with position along the barrel, and with time, for the 8-inch gun, Mark VIII with charge weight 29.484 kgm. [case C(a)] :—

* This implies that the loss in efficiency is approximately inversely proportional to \sqrt{C} , since the total energy is proportional to C ; this and the result given in the next paragraph are interesting verifications of the law given in Section 8.18 which was determined empirically from firings.

Surface temperatures in °C.

| x (cm.) | 90 | 180.5 (commencement of rifling) | 229 | 293 | 505 |
|-----------------|-----|---------------------------------------|------|-----|-----|
| t (millisec.) | | | | | |
| 0 | 15 | 15 | | | |
| 2 | 64 | 90 | | | |
| 4 | 244 | 359 | | | |
| 6 | 520 | 749 | 15 | | |
| 8 | 724 | 1012 | 863 | 15 | |
| 10 | 783 | 1073 | 1036 | 904 | |
| 12 | 763 | 1037 | 1016 | 967 | 15 |
| 14 | 717 | 970 | 962 | 938 | 689 |
| 16 | 666 | 901 | 893 | 874 | 727 |
| 18 | 619 | 837 | 831 | 820 | 710 |
| 20 | 577 | 781 | 774 | 762 | 677 |

In general, the highest inner-surface temperatures occur at the commencement of rifling, as is illustrated by the above table, and there is a considerable variation from gun to gun. In particular, the 25-pounder, which is a low-velocity gun, has a very low maximum temperature, less than 600°C. The highest surface temperature obtained was about 1160°C. for the two-pounder model ; this is well below the melting temperature of steel (about 1500°C.).

The next table gives an example of the temperature distribution inside the barrel, for the 8-inch gun, Mark VIII, charge weight 29.484 kgm., at about the time when the maximum inner-surface temperature is attained :—

Temperatures inside the barrel at the commencement of rifling (x_0)
Case C(a) $t = 10$ millisec.

| z (cm.) | 0 | 0.01 | 0.02 | 0.04 | 0.06 | 0.08 | 0.10 |
|------------------|------|------|------|------|------|------|------|
| Temperature (°C) | 1073 | 732 | 451 | 139 | 42 | 20 | 16 |

The temperature always falls off very rapidly inside the barrel, and the penetration of heat during the firing of a single shot is quite small—about one millimetre in this particular example.

BIBLIOGRAPHY

For brevity, journals and reports are referred to by the following notation :—

| | |
|--------------------|---|
| A.C.../I.B... | Advisory Council on Scientific Research and Technical Development. (London). Internal ballistics sub-committee paper. |
| A.C.../Bal... | Ballistics committee paper. |
| Ann. Min. | Annales des Mines (Paris). |
| A.R.D. Bal. | Armament Research Department Ballistics Report. |
| A.R.D. Th. | Armament Research Department Theoretical Report. |
| A.R.D. Th. M. | Armament Research Department Theoretical Memorandum. |
| Arm. Ord. | Army Ordnance (Washington). |
| Art. Mon. | Artilleristische Monatshefte (Berlin). |
| B.R.L. | Ballistics Research Laboratory report, Aberdeen (U.S.A.). |
| Bull. Belge. | Bulletin Belge des Sciences Militaires (Brussels). |
| Bull. ren. Art. | Bulletin de renseignements de l'Artillerie (Paris). |
| Bull. Soc. Chim. | Bulletin de la Société Chimique de France (Paris). |
| Coast Art. Jour. | Coast Artillery Journal (U.S.A.). |
| C.R. | Comptes Rendus de l'Académie des Sciences (Paris). |
| Dansk. Art. Tid. | Dansk Artilleri Tidsskrift (Copenhagen). |
| I.B.R.L. | Internal Ballistics Research Laboratory Report (Valcartier). |
| Jour. Eng. Tokio. | Journal of the Faculty of Engineering, Imperial University (Tokio). |
| Jour. Frank. Inst. | Journal of the Franklin Institute (Philadelphia). |
| Jour. Phys. | Journal de Physique (Paris). |
| Jour. Roy. Art. | Journal of the Royal Artillery (London). |
| M.C.S. G.M. | Publication of the Gunnery and Mathematics Branch of the Military College of Science. |
| M.C.S.P. | Publication of the Physics Branch of the Military College of Science. |
| Mem. Art. | Memorial de Artilleria (Madrid). |
| Mem. Art. Fr. | Mémoire de l'Artillerie Française (Paris). |
| Mem. Poud. | Mémoire des Poudres (Paris). |
| N.D.R.C. | National Defense Research Committee Report (U.S.A.). |
| Norsk. Art. Tid. | Norsk Artilleri Tidsskrift (Norway). |
| Ord. Ctte. | Ordnance Committee Publication (London). |
| O.S.R.D. | Office of Scientific Research and Development Report (U.S.A.). |
| P. and E.E. | Proof and Experimental Establishment (Woolwich) Report. |
| Phil. Mag. | Philosophical Magazine and Journal of Science (London). |
| Phil. Trans. | Philosophical Transactions of the Royal Society (London). |
| Proc. Nat. Acad. | Proceedings of the National Academy of Science of U.S.A. (Washington). |
| Proc. Roy. Soc. | Proceedings of the Royal Society of London. |

| | |
|-----------------|---|
| R.D. | Research Department (Woolwich) Report. |
| Rev. Art. | Revue d'Artillerie (Paris). |
| Rev. Gen. Mar. | Revista General de Marina (Madrid). |
| Riv. Art. | Rivista di Artiglieria e Genio (Rome). |
| Sc. Bur. Stand. | Scientific Papers of the Bureau of Standards (Washington). |
| Tech. Mitt. | Technische Mitteilungen (Germany). |
| U.S. Nav. Inst. | United States Naval Institute Proceedings (Annapolis). |
| Voj. Tech. Zpr. | Vojensko Technicke Zpravy (Prague). |
| Weh. Mon. | Wehrtechnische Monatshefte (Germany). |
| Zeit. Sch. Spr. | Zeitschrift für das gesamte Schiess-und Spreng-Stoffwesen (Munich). |
| Z.V.D.I. | Zeitschrift des Vereines Deutscher Ingenieure (Berlin). |

ABEL, F. A.

Modes of explosion of gun cotton. Phil. Trans. 159, p. 489 (1869). See also Noble, A.

ALDRICH, M. G.

See Hirschfelder, J. O.

ALGER, P. R.

The Le Duc velocity formula. U.S. Nav. Inst. 37, p. 535 (1911).

AUNIS, G.

See Muraour, H.

AZAROLA, A.

The evaluation, from the energy point of view, of the various effects in a 30.5 cm. gun. Rev. Gen. Mar. p. 289 (1936).

BALLEISEN, C. E.

Derivation of factor to correct gauge pressure to pressure at the breech. B.R.L. (1938).
Calculations for a calibre 0.50 gun having 4000 f.s. muzzle velocity. B.R.L. 124. (1938).

BARNES, L. W.

See Laidler, K. J.

BATE, M.

See Watson, G. D.

BECKER, F.

See Schmidt, A.

BERGMANN, W.

Lärobok i artilleriteknik. Vol. I. Pub. by Nordstedt, Sweden (1908).

BERNARD, P.

The piezo-electric measurement of pressures. Mem. Art. Fr. 17, p. 323 (1938).

BIANCHI, G.

Nozioni fondamentali di balistica interna. Paota, Turin, Castello, (1915).

BINGEN, J. N.

La technique de l'artillerie. Vol. 1. Balistique intérieure. Pub. in Bruges (1937).

BODLIEN, K. H.

Internal ballistics of rifled barrels. Zeit. Sch. Spr. 34 (1939).

BOLLE, E.

On the determination of the variation of gas pressure during firing. Jour. Phys. p. 702 (1923).
Einleitung zur inneren Ballistik. Pub. by Vieweg, Germany (1930).

BOURGOIN

On the rate of burning of colloidal propellants. C.R. p. 532 (1922).

BOYS, S. F.

(With Corner, J.). The structure of the reaction zone in the burning of a colloidal propellant. A.C.1139/I.B.8. (1941).

An attempt at an investigation of the internal ballistics problem of a gun with improved accuracy. A.C.9038/Bal. 307 (1946).

(With Lester, G. R.) A direct method for determining temperature coefficients of burning rate by simultaneous interrupted burning of hot and cold samples. A.R.D. Bal. 18/45 (1945).

BURLLOT, E.

Note on the resistance offered by metals to rapid deformations. Application to the measurement of the pressure developed in a closed vessel by a burning propellant. Mem. Poud. p. 255 (1923).

Note on the measurement of pressures developed in a closed vessel by a burning propellant. Mem. Poud. p. 403 (1924).

Note on the experimental determination of the force and co-volume of explosives. Mem. Poud. p. 411 (1924).

CAMBRIDGE MATHEMATICAL LABORATORY (Staff of)

The application of the Bush differential analyser to problems of internal ballistics :—

The 25-pr. gun and B.L. 8-in. guns. A.C.1374/I.B.38 (1941).

A gun having a conical barrel. A.C.1375/I.B.39 (1941).

The internal ballistics of the 2-pr. gun. A.C.1955/I.B.76 (1942). A.C.2191/I.B.94 (1942).

The effect of shot-start pressure on gun ballistics. A.C.2190/I.B.93. (1942).

CENTERVALL, A. F.

Internal Ballistics. English translation by Tulloch, T. G. Pub. by H.M.S.O. London (1902).

CHALLEAT, J.

Théorie des affuts à déformation, Rev. Art. 65 (1904).

CHALVET, M.

Principles of piezo-electricity. The measurement of pressure. Mem. Art. Fr. p. 1001 (1931).

CHARBONNIER, P.

Balistique intérieure. Pub. by Doin, Paris (1908).

On pyrostatics. Riv. Art. p. 5 (1918).

The "Veine gazeuse." Mem. Art. Fr. p. 1001 (1922).

Internal ballistics from 1737 until modern times. Mem. Art. Fr. p. 1113 (1926).

CHATELIER, LE

See Mallard, E.

CHEERNICK, J.

See Vinti, J. P.

CLEMMOW, C. A.

General theory of composite charges. R.D. 41. Pub. by H.M.S.O. (1920).

A theory of internal ballistics based on a pressure-index law of burning for propellants. Phil. Trans. A.227, p. 345 (1928).

The differential equations of ballistics. Phil. Trans. A.231, p. 263 (1933).

COPPOCK, S. W.

Extension of ballistic theory of R.D. 38 with a view to predicting *true* pressure-space curves. A.C.1455/I.B.45 (1941).

The methods of internal ballistic calculation in use in the Research Department. A.R.D. Bal. 82/42 (1942).

CORNER, J.

Theories of flame-speeds in gases. A.R.D. Th. 1/43 (1943).

Theories of the burning of colloidal propellants. A.R.D. Th. 2/43 (1943).

Tables of pressure corrections in the thermochemistry of propellant explosions. A.C. 5646/Bal. 147 (1943).

The derivation of pressure corrections in the thermochemistry of propellant explosions. A.C. 5807/Bal. 158 (1943).

(With Vickers, T.). A theory of the internal ballistics of recoilless guns. A.C.6351/Bal. 185 (1944).

(With Vickers, T.). The optimum size of chamber for a recoilless gun. A.C. 7467/Bal. 223 (1944).

(With Vickers, T.). The influence of peak pressure on the weight of a recoilless gun. A.C. 7659/Bal. 236 (1944).

A theory of the internal ballistics of the high-low pressure gun. A.R.D. Th. M. 22/45, (1945). Also Jour. Frank. Inst. Vol. 246 No. 3 (Sept., 1948).

(With Ware, H. N.). A possible revision of tables of pressure corrections in the thermochemistry of propellant explosions. A.C. 8874/Bal. 300 (1945).

(With Vickers, T. and Ware, H. N.). A theory of the internal ballistics of a worn gun. A.C. 8926/Bal. 301 (1945).

(With Pack, D. C.). The motion of cordite in a gun. A.C. 9026/Bal. 306 (1945).

The internal ballistics of a leaking gun. Proc. Roy. Soc. A. Vol. 188 (1947).

Further theoretical work on the internal ballistics of the high-low pressure gun. A.C. 9076/Bal. 308 (1946).

The ballistic effects of bore resistance. Quart. Journ. Mech. and Applied Math. Vol. II, pt. 2 (1949).

(With Owen, P. L.) Pressure-time curves after shot ejection. A.R.D. 11/47 (1947).

The internal ballistics of a gun after shot ejection. Proc. Roy. Soc. A vol. 188 (1947).

See also Boys, S. F. and Lennard-Jones, J. E.

CRAIG, R. A.

See Duncan, J. A.

CRANK, J.

(With Wood, A. M.). The use of linear rate of burning law in place of an index law in internal ballistics. A.C. 5570/Bal. 145 (1943).

(With Hill, R.). Effect of various types of band resistance on gun ballistics. A.C. 7122/Bal. 212 (1943).

Families of solutions of the internal ballistics equations. A.C. 4503/I.B. 202 (1943).

CRANZ, C.

A graphical solution of the principal problem of internal ballistics based on thermodynamical principles. Art. Mon. p. 89 (1918).

Lehrbuch der Ballistik, Bd. II, Innere Ballistik. Pub. by Springer (Berlin, 1926).

CROCKER, J. A.

See Smith, N. M.

COPPOCK, S. W.

Extension of ballistic theory of R.D. 38 with a view to predicting *true* pressure-space curves. A.C.1455/I.B.45 (1941).

The methods of internal ballistic calculation in use in the Research Department. A.R.D. Bal. 82/42 (1942).

CORNER, J.

Theories of flame-speeds in gases. A.R.D. Th. 1/43 (1943).

Theories of the burning of colloidal propellants. A.R.D. Th. 2/43 (1943).

Tables of pressure corrections in the thermochemistry of propellant explosions. A.C. 5646/Bal. 147 (1943).

The derivation of pressure corrections in the thermochemistry of propellant explosions. A.C. 5807/Bal. 158 (1943).

(With Vickers, T.). A theory of the internal ballistics of recoilless guns. A.C.6351/Bal. 185 (1944).

(With Vickers, T.). The optimum size of chamber for a recoilless gun. A.C. 7467/Bal. 223 (1944).

(With Vickers, T.). The influence of peak pressure on the weight of a recoilless gun. A.C. 7659/Bal. 236 (1944).

A theory of the internal ballistics of the high-low pressure gun. A.R.D. Th. M. 22/45, (1945). Also Jour. Frank. Inst. Vol. 246 No. 3 (Sept., 1948).

(With Ware, H. N.). A possible revision of tables of pressure corrections in the thermochemistry of propellant explosions. A.C. 8874/Bal. 300 (1945).

(With Vickers, T. and Ware, H. N.). A theory of the internal ballistics of a worn gun. A.C. 8926/Bal. 301 (1945).

(With Pack, D. C.). The motion of cordite in a gun. A.C. 9026/Bal. 306 (1945).

The internal ballistics of a leaking gun. Proc. Roy. Soc. A. Vol. 188 (1947).

Further theoretical work on the internal ballistics of the high-low pressure gun. A.C. 9076/Bal. 308 (1946).

The ballistic effects of bore resistance. Quart. Journ. Mech. and Applied Math. Vol. II, pt. 2 (1949).

(With Owen, P. L.) Pressure-time curves after shot ejection. A.R.D. 11/47 (1947).

The internal ballistics of a gun after shot ejection. Proc. Roy. Soc. A vol. 188 (1947).

See also Boys, S. F. and Lennard-Jones, J. E.

CRAIG, R. A.

See Duncan, J. A.

CRANK, J.

(With Wood, A. M.). The use of linear rate of burning law in place of an index law in internal ballistics. A.C. 5570/Bal. 145 (1943).

(With Hill, R.). Effect of various types of band resistance on gun ballistics. A.C. 7122/Bal. 212 (1943).

Families of solutions of the internal ballistics equations. A.C. 4503/I.B. 202 (1943).

CRANZ, C.

A graphical solution of the principal problem of internal ballistics based on thermodynamical principles. Art. Mon. p. 89 (1918).

Lehrbuch der Ballistik, Bd. II, Innere Ballistik. Pub. by Springer (Berlin, 1926).

CROCKER, J. A.

See Smith, N. M.

CROW, A. D.

A short method of calculation of internal ballistics and its application to gun design. R.D. 38. Pub. by H.M.S.O. (1920).

The behaviour under compression of Service copper crushers. R.D. 64. Pub. by H.M.S.O. (1927).

(With Grimshaw, W. E.). The equation of state of propellant gases. *Phil. Trans. A.* 230, p. 39 (1931).

(With Grimshaw, W. E.). The combustion of colloidal propellants. *Phil. Trans. A.* 691, p. 387 (1932).

(With Grimshaw, W. E.). The combustion problem of internal ballistics. Pt. I. *Phil. Mag.* p. 529 (1933); Pt. II. *Phil. Mag.* p. 729 (1933).

(With Grimshaw, W. E.). The combustion of colloidal propellants. *Phil. Mag.* p. 161 (1934).

CURTISS, C. F.

See Hirschfelder, J. O.

DAISH, C. B.

The photo-cell counter chronometer. *M.C.S.P.* 2 (1946).

DEDERICK, L. S.

Kinetic energy of gases in a gun of varying cross-section. *B.R.L.* (1935).

DESMAZIERES, F.

Note on the present state of internal ballistics. *Rev. Art.* p. 241 (1920).

The two French schools of internal ballistics. *Rev. Art.* p. 467 (1920).

Questions of internal ballistics. *Mem. Poud.* p. 181 (1922).

The measurement of absolute pressures by means of crushers. *Mem. Art. Fr.* p. 777 (1922).

First memoir on internal ballistics. *Mem. Art. Fr.* p. 19 (1922).

Examination of the principal theoretical studies of internal ballistics published abroad from 1913 to 1922. *Mem. Art. Fr.* p. 1009 (1924).

The ballistic effects of propellants. *Mem. Art. Fr.* p. 1261 (1926).

Note on a ballistic problem. *Mem. Poud.* p. 241 (1926).

Conference on internal ballistics. *Mem. Art. Fr.* p. 633 (1929).

DUMAS, R. L.

See Watson, G. D.

DUNCAN, J. A.

(With Craig, R. A.). Investigation of the effect of time and metallic surface on the cooling of cordite M.D. gases and its application to the gun. R. D. 15 (1911).

DUNN, B.

Internal ballistics (nitrocellulose calculations). U.S. Ord. Office Publication 89 (1906).

DUPUIS, J.

Note on the law of burning of propellants. *Mem. Art. Fr.* p. 799 (1938).

EMERY, E.

Notions of internal ballistics, *Bull. ren. Art.*, p. 7 (1918).

Note on similitudes in internal ballistics. *Mem. Art. Fr.* p. 22 (1923).

FERRER

Methods of internal ballistics. *Mem. Art.* p. 206 (1923).

An expression for the gas pressure on the breech of a gun as a function of the time. *Jour. Roy. Art.* p. 37 (1923).

FORD, A.

Experiments in pressure measurement at Aberdeen Proving Ground. Mem. Art. Fr. p. 229 (1928).

FOWLER, R. G.

Comparison of flow through a rifled barrel and smooth bore tube at high speeds. A.C. 3097/I.B. 144 (1942).

FREMR, V.

Calculation of table for the fundamental quantities of internal ballistics. Voj. Tech. Zpr. p. 158 (1928).

GABEAUD, L.

On the theory of passive resistance in a gun. Mem. Art. Fr. p. 273 (1930).

GEBAUER, J.

Note on H. Muraour's papers "On the laws of burning of colloidal propellants" and "The influence of temperature on the quickness of propellants." Voj. Tech. Zpr. p. 105 (1928).

GERLICH, H.

Increased bullet speeds. Effects and possibilities of a German rifle and its ammunition. Arm. Ord. p. 398 (1930).

GOLDIE, A. W.

A system of internal ballistics for routine and research purposes. A.R.D. Bal. 10/45 (1945).

A method for the calculation of pressure-space curves and its application to a problem in gun design. A.R.D. Bal. 18/46 (1946).

A numerical comparison of British and American internal ballistics systems. A.R.D. Bal. Rep. 19/46 (1946).

GOODE, J. B.

(With Lockett, N.) The space and time variation of pressure in the bore of a gun. A.R.D. Bal. 31/44 (1944).

GOSSOT, F. AND LIOUVILLE, R.

Traité des effets des explosifs. Pub. in Paris. 3 vols. (1919).

Reflections on internal ballistics. Rev. Art. p. 18 (1920) and p. 211 (1921).

On the principles of internal ballistics. Mem. Poud. p. 1 (1922); p. 191 (1926).

Ballistique intérieure. Pub. in Paris (1922).

On the principles of internal ballistics. C.R. p. 27 (1922); p. 1539 (1923); p. 1014 (1925); p. 503 (1926).

On a ballistic problem. Mem. Poud. p. 1 (1928).

On new principles of internal ballistics. Mem. Poud. p. 237 (1928).

GREEN, H.

See Pike, H. H. M.

GRIFFITHS, E.

See Thornhill, C. K.

GRIMSHAW, W. E.

See Crow, A. D.

GUTIERREZ, J. S.

Conferencias sobre ballística interior. Segovia (1924).

HADCOCK, G.

Internal ballistics. Proc. Roy. Soc. p. 479 (1918).

- HAESSEN, E.
Cours de balistique intérieure. Brussels (1904).
- HANNAN, P. J.
See Urry, W. D.
- HARDCASTLE, J. H.
Monomial formulae for the pressure and velocity of firearms. Jour. Roy. Art. pp. 337 and 389 (1915), p. 157 (1918).
- HASSE, H. R.
See Henderson, J. B.
- HAYES, T. J.
Elements of ordnance. Pub. in U.S.A. (1949).
- HEFFERNAN, N. B.
Internal ballistics. Confid. pub. by H.M.S.O. (1907).
- HENDERSON, J. B.
(With Hassé, H. R.). A contribution to the thermodynamical theory of explosions. Proc. Roy. Soc. p. 461 (1922).
- HEPNER, W.
Solutions for the motion of the powder gas in a cylindrical gun tube. A.C. 4297/I.B. 192 (1943).
- HEYDENREICH, W.
Lehre vom Schuss Bd. II. Pub. in Berlin (1908).
- HEZLET, R. K.
Interior ballistics with M. D. Cordite. Jour. Roy. Art. p. 328 (1912).
Interior ballistics. Experimental facts and formulae. Jour. Roy. Art. p. 97 (1917).
A simple thermodynamical system of internal ballistics. Ord. Ctte. (1919).
Interior ballistics. A thermo-chemical method. Ord. Ctte. (1923).
- HICKMAN, M. J.
See Thornhill, C. K.
- HICKS, E. P.
(With Thornhill, C. K.). Notes on the pressure distribution along a gun barrel. A.C. 1660/I.B. 59 (1942).
(With Thornhill, C. K.). Notes on the use of a cool, high-force propellant to increase the life of gun barrels, with particular reference to the 0.5 in. Browning machine gun. A.R.D. Th. M. 13/45 (1945).
See also Thornhill, C. K.
- HINDS, G. H.
Occasion-to-occasion variations in muzzle velocity. A.C. 4886/I.B. 209 (1943).
See also Hunt, F. R. W.
- HIRSCHFELDER, J. O.
(With McClure, F. T. and Curtiss, C. F.). Thermochemistry and the equation of state of the propellant gases. N.D.R.C. A48. O.S.R.D. 547 (1942).
(With Sherman, J.). Simple calculations of thermo-chemical properties for use in ballistics. N.D.R.C. A.101, O.S.R.D. 935 and N.D.R.C. Memos. A67M to A70M, O.S.R.D. 1300 (1943).
(With McClure, F. T., Curtiss, C. F. and Osborne, D. W.). Thermodynamic properties of propellant gases : an extension and revision of N.D.R.C. A48. N.D.R.C. A116, O.S.R.D. 1087 (1942).
(With Kershner, R. B., Curtis, C. F. and Johnson, R. E.). Interior ballistics of recoilless guns. N.D.R.C. A215, O.S.R.D. 1801 (1943).

HITCHCOCK, H. P.

Differential coefficients for interior ballistics. B.R.L. 169 (1940).

The effect of increase in starting pressure on the efficiency and velocity of calibre 0.30 weapons. B.R.L. 244 (1942).

HUGONIOT, A.

See Sebert, H.

HUNT, F. R. W.

(With Wright, C. E.). A solution of the principal internal ballistic problem for long elliptic cords. Jour. Roy. Art. p. 443 (1922).

(With Hinds, G. H.). Rate of burning of colloidal propellants. Proc. Roy. Soc. A.138 p. 696 (1932).

(With Hinds, G. H. revised by Tranter, C. J.). A system of internal ballistics. M.C.S. G.M. II (1945).

HYMANS, J. C. S.

Notes on internal ballistic formulae for muzzle velocity and pressure. P. and E.E. 3/43 (1943).

INGALLS, J. M.

Interior ballistics. Pub. in New York (1912).

JOHNSON, R. E.

See Hirschfelder, J. O.

JONES, A. E.

(With Stocks, K. M.). Loss of muzzle velocity from gun erosion ; a statistical analysis. A.R.D. Bal. 37/44 (1944).

JOUGUET

Mécanique des explosifs. Pub. in Paris (1917).

KARCHER, J. C.

A piezo-electric method for the instantaneous measurement of high pressure. Sc. Bur. Stand. p. 257 (1923).

KENT, R. H.

Some special solutions for the motion of the powder gas. Physics, Vol. 7, No. 9 (1936).

(With Vinti, J. P.). Cooling corrections for closed chamber firings. B.R.L. 281 (1942).

Röggla's equation and its application to interior ballistic problems, (revised) with addendum by J. P. Vinti. B.R.L. 48 (1941).

KERSHNER, R. B.

See Hirschfelder, J. O.

KEYS, D. A.

A piezo-electric method of measuring explosion pressures. Phil. Mag. p. 473 (1921).

The cathode ray oscillograph and its application to the exact measurement of explosion pressures, etc. Jour. Frank. Inst. p. 577 (1923).

KUTTERER, R. E.

Measurement of the resistance to the shot in the bore of a gun. Weh. Mon. pp. 496, 536 (1935).

Ballistik. Pub. in Germany (1942).

LACEY, L. J.

The internal ballistics of long guns working at low pressures. A.R.D. Bal. 23/45 (1945).

(With Ruston, A. F.). Estimation of pressure-space curves. A.R.D. Bal. 29/45 (1945).

LAGRANGE, J. L.

Recherches sur la force de la poudre. Oeuvres VII p. 603 (1793).

LAIDLER, K. J.

(With Barnes, L. W.). Internal ballistic considerations in connection with high-velocity guns. I.B.R.L.2 (1943).

LAMOthe, A.

Examination of the principal works on the theory of copper crushers. Mem. Art. Fr. p. 827 (1922) and p. 633 (1935).

Essay on the theory of copper crushers. Mem. Art. Fr. p. 673 (1935) and p. 529 (1937).

LANGEVIN, P.

Note on the ballistic effect of the propellant gases in the convergent-divergent tube. Mem. Art. Fr. p. 1 (1923).

LANGWEILER, H.

Development and experimental application of complete mathematical expressions for internal ballistic quantities. Zeit. Sch. Spr. 33 (1938).

LE CHATELIER, H.

See Mallard, E.

LEES, C. H.

(With Petaval, J.). On the variation of pressure developed during the explosion of cordite in closed vessels. Proc. Roy. Soc. (1907).

LENNARD-JONES, J. E.

Design of a gun of overall length for optimum performance. A.C. 2497/I.B. 117 (1942).
(With Corner, J.). The burning of a propellant and the effect of gas flow over its surface. A.C. 1173/I.B. 19 (1941).

LEPLAT, G.

Note on the internal ballistic calculation by means of the Charbonnier-Sugot formulae and the various tables used to facilitate these calculations. Mem. Art. Fr. p. 151 (1925).

LESTER, G. R.

See Boys, S. F.

LETANG, M.

On the phenomena produced during burning in a closed vessel. Rev. Art. p. 1313 (1919).
Memoir on the burning of propellants in a closed vessel. Mem. Art. Fr. p. 955 (1922).

LIOUVILLE, R.

See Gossot, F.

LOCKETT, N.

See Goode, J. B.

LONGRIDGE, J. A.

Internal ballistics. Pub. in England (1889).

LORENZ, H.

Fundamental principles of artillery (internal ballistics). Z.V.D.I. p. 625 (1916).
Integration of the internal ballistic differential equations. Art. Mon. p. 69 (1917).
Ballistik. Pub. in Germany (1917).The mechanical effect of propellant powders in a gun. Zeit. Sch. Spr. p. 452 (1917).
Ballistik. Die mechanischen und thermodynamischen Grundlagen der Lehre. Pub. in Munich (1935).

LOVE, A. E. H.

(With Pidduck, F. B.). The Lagrange ballistic problem. *Phil. Trans.* p. 167 (1923).

MACHE

The rate of burning of colloidal powders and the pressure developed in a closed vessel as a function of time, propellant shape and density of loading. *Zeit. Sch. Spr.* p. 97 (1916).

On the motion of a projectile in a gun during the burning of the powder. *Tech. Mitt.* p. 1059 (1916).

On the temperature of burning of colloidal powders. *Tech. Mitt.* p. 1546 (1918).

MALAVAL, P.

On Lamothe's note—Examination of the principal works on the theory of copper crushers. *Mem. Art. Fr.* p. 905 (1922).

MALLARD, E.

(With Le Chatelier). Explosion temperatures and specific heats of gases at high temperatures. *Ann. Min.* p. 379 (1883).

(With Le Chatelier). Calculation of explosion temperatures. *Mem. Poud.* p. 442 (1884).

MANNERS-SMITH, E. V.

Assessment of the practical value of various types of check firing. *P. and E.E.* 1/43 (1943).

MANNING

Practical interior ballistics. *Coast. Art. Jour.* pp. 414, 494 (1919).

MANSELL, J. H.

Investigation of the law of burning of modified cordite. *Phil. Trans.* p. 243 (1907).

MARSH H. N.

Measuring cannon pressures. *Arm. Ord.* p. 15 (1936).

MASCARUCCI

Fundamental demonstration of a formula of internal ballistics. *Rev. Art.* p. 203 (1925).

MAURIN

Research on the maximum range of a gun of given length. *Rev. Art.* p. 240 (1921); p. 40 (1922).

Approximate determination of the characteristics of a fire-arm. *Norsk. Art. Tid.* p. 30 (1922).

McCLURE, F. T.

See Hirschfelder, J. O.

MICHEL-LEVY, A.

(With Muraour, H.). On the explosion temperature of colloidal propellants. *C.R.* p. 40 (1931).

Note on the explosion temperature of colloidal propellants. *Bull. Soc. Chim.* p. 1211 (1931).

MOOR, DE

Study of internal ballistics. *Bull. Belge.*, p. 185 (1935); p. 217 (1936).

Some general ideas on internal ballistics. *Bull. Belge.*, pp. 453, 596 (1936).

The ballistics of high muzzle velocities. *Bull. Belge.*, p. 229 (1936).

MURAOUR, H.

Note on the influence of cooling on the measurement of explosive pressures. *Mem. Poud.* p. 323 (1923); p. 339 (1924).

Remarks on some experiments of Krupp's relative to the combustion of propellants in closed vessels. *Mem. Art. Fr.* p. 365 (1924).

- Comparison between explosion temperatures calculated from explosion pressures and those calculated from specific heats. Mem. Art. Fr. p. 349 (1924).
 Note on the theory of crushers. Mem. Art. Fr. p. 229 (1925).
 Notes on internal ballistics. Mem. Art. Fr. p. 455 (1925).
 The influence of temperature on the quickness of propellants. Bull. Soc. Chim. p. 846 (1926).
 On the laws of burning of colloidal propellants. Bull. Soc. Chim. p. 981 (1926); p. 1451 (1927); C.R. p. 374 (1928); Mem. Art. Fr. p. 381 (1930).
 On the relation between the temperature of explosion of a propellant and its rate of burning C.R. p. 289 (1928).
 Study of the laws of burning of colloidal propellants. Bull. Soc. Chim. p. 261 (1930).
 (With Aunis, G.). On the agreement between calculated and experimental pressures of explosion. C.R. p. 1389 (1930).
 Comparison of calculated and experimental pressures of explosion. C.R. p. 1547 (1930).
 On the variation of f_{pdt} with loading density for different types of propellant. C.R. p. 90 (1931).
 On the laws of burning of propellants containing vaseline. C.R. p. 418 (1931).
 On the theory of the burning of colloidal propellants in a closed vessel. C.R. p. 227 (1931).
 The influence of humidity on the rate of burning of colloidal propellants. Bull. Soc. Chim. p. 268 (1931).
 On the experimental determination of the drop in temperature obtained by adding various substances to Poudre B. Mem. Art. Fr. p. 125 (1933).
 Note on the erosive qualities of mixtures of Poudre B with various substances added to lower the explosion temperature. Mem. Art. Fr. p. 441 (1933).
 (With Aunis, G.). Study of the laws of burning of colloidal propellants. C.R. p. 177 (1936).
 Contribution to pressure measurement in a bomb, etc. Mem. Art. Fr. p. 579 (1938).
 Poudres et Explosifs. Pub. by Presses Universitaires de France, Paris (1947).
 See also Michel-Levy, A.

NATIONAL BUREAU OF STANDARDS

(With Geophysical Laboratory, Carnegie Institution of Washington).

- Report on firing of first eleven rounds in 3-in. gun at David W. Taylor Model Basin during May, June, July, 1943. NDRC A-229 : OSRD No. 2019 (1943).
 Second report on firings in 3-in. gun at David W. Taylor Model Basin, October 1943 to May 1944. NDRC A-323 : OSRD. No. 4986 (1945).

NEGRETTO

Ballística experimental y aplicado. Pub. in Madrid (1920).

NICHOLSON, M. M.

Tabulation of the Hunt-and-Hinds system of internal ballistics. A.C. 8335/Bal. 281 (1945).

NOBLE, A.

Abel's law. C.R. p. 204 (1874).
 (With Abel, F.). Researches on gun powder. Phil. Trans. p. 97 (1875).
 Artillery and explosives. Pub. in England (1906).

NORDHEIM, G.

See Nordheim, L. W.

NORDHEIM, L. W.

(With Soodak, H. and Nordheim, G.). Thermal effects of propellant gases in erosion vents and in guns. N.D.R.C. A.262, O.S.R.D. 3447 (1944).

NOWAKOWSKI, C. A.

Contribution to a study of internal ballistics, etc. Tech. Mitt. pp. 1135, 1321 (1917).

OSBORNE, D. W.

See Hirschfelder, J. O.

OTTENHEIMER, J.

Balistique intérieure. Pub. in Paris (1926).

Experimental research on the law of pressure development as a function of time. Mem. Art. Fr. p. 25 (1927).

OWEN, P. L.

See Corner, J.

PACK, D. C.

See Corner, J.

PACHMANN-BOGOTA, W.

See Wenzel, F.

PAPPAS, A.

On the family of curves of internal ballistics. Heerestechnik, p. 161 (1930).

PATTERSON, G. W.

The Le Duc ballistic formula. U.S. Nav. Inst. p. 885 (1912).

PAUW, DE

The heat of combustion of smokeless powder. Zeit. Sch. Spr. pp. 10, 36 (1937).

PETAVEL, J.

Pressure of explosions. Experiments on solid and gaseous explosives. Phil. Trans. p. 357 (1905).

See also Lees.

PIDDUCK, F. B.

Gun calculations by a modification of the method of cooling. R.D. 15, Appendix II (1916).

See also Love, A. E. H.

PIKE, H. H. M.

Thermochemical data for the products of propellant explosions. A.C. 1862/I.B. 78 (1940).

Thermochemistry of propellant explosions. A.C. 1453/I.B. 43 (1941).

The conversion of data from closed vessel firings for use in simplified ballistics calculations. A.C. 2874/I.B. 137 (1942).

The effect of initial temperature on the ballistic properties of propellants. A.C. 7123/Bal. 213 (1944).

(With Green, H.). An alternative method of measuring the rates of burning of propellants and its application to S.C. A.R.D. Bal. 16/44 (1944).

The correction of measurements of calorimetric value to standard conditions. A.R.D. Bal. 6/46 (1946).

PLATRIER, C.

Analysis of Lagrange's ballistic problem of internal ballistics. Mem. Art. Fr. p. 431 (1936).

POLANSKY, F.

The application of the Charbonnier-Sugot method of internal ballistics. Voj. Tech. Zpr. p. 73 (1936).

PROUDMAN, J.

The principles of internal ballistics. Proc. Roy. Soc. A.100 (1931).

RAABYE

The influence of pressure on the burning of black powder. *Dansk. Art. Tid.* p. 165 (1925).

RAMSEY, N. F.

The derivation of the travel-time curve for the Gerlich rifle from the observed pressure-time curve. *B.R.L.* (1935).

REGII, S.

On the burning of powders in a vessel of constant volume. *Riv. Art.* p. 5 (1917).

On the form function for colloidal powders. *Riv. Art.* p. 115 (1918).

Study of internal ballistics. *Riv. Art.* p. 255 (1919).

Polveri ed esplosivi e loro effetti. Pub. in Rome (1923).

The ballistics of powders of constant burning surface. *Riv. Art.* p. 167 (1924).

A practical form of the solution of the fundamental problem of internal ballistics. *Riv. Art.* p. 113 (1925).

RESAL, H.

Recherches sur le mouvement des projectiles dans les armes à feu. Pub. in Paris (1864).

RESEARCH DEPARTMENT, WOOLWICH (Staff of)

Pressure measurement for ballistic research. *A.C.* 1226/*I.B.* 23 (1941).

Pressure-shot-travel curves. *A.C.* 1091/*I.B.* 25 (1941).

Theoretical pressure-shot travel relationships in guns. *A.C.* 1174/*I.B.* 26 (1941).

A note on hyper-velocity guns. *A.C.* 2055/*I.B.* 81 (1942).

High-velocity guns. *A.C.* 2185/*I.B.* 90 (1942).

The relation between piezo-electric and copper pressures. *A.C.* 3422/*I.B.* 157 (1942).

RIABOUCHINSKY, D.

On some researches in ballistics. *Mem. Art. Fr.* p. 689 (1923).

RIBAUD, G.

On the calculation of temperatures and pressures of combustion in a closed vessel. *C.R.* p. 1139 (1937).

RIENSBERG

The ratio of mean to maximum pressure in various weapons. *Art. Mon.* p. 155 (1916).

RIFFOLT, N.

See Thompson, L.

RINDERKNECH, C.

Essay on the theory of ballistic similitudes. *Mem. Art. Fr.* p. 1275 (1926).

ROBERTSON, R.

Constants of explosion of cordite. *Proc. Roy. Soc.* p. 320 (1906).

ROBINS, B.

New principles of gunnery. New edn. revised by C. Hutton, F.R.S. Pub. in England (1805).

RÖGGLA, E.

Neue Diagramme für die angewandte innere Ballistik. Pub. in Pilsen (1930).

ROHNE, H.

Questions of internal ballistics. *Zeit. Sch. Spr.* pp. 1, 84, 117, 159 (1931).

ROSSMANN, T.

Recent researches in internal ballistics. *Sch. der Deutschen Akademie der Luftfahrtforschung* p. 23 (1940).

Researches on gas-flow in guns and blast effect. *Sch. der Deutsch. Akad. der Luftfahrtforschung*, p. 261 (1941).

ROWELL, H. S.

Simple method for calculating sizes of cordite. *Jour. Roy. Art.* p. 238 (1917).

RUSTON, A. F.

See Lacey, L. J.

SARRAU, E.

(With Vieille, P.). Mode of decomposition of various explosives. *Mem. Poud.* p. 126 (1885). See also *Mem. Poud.* p. 21 (1882), p. 79 (1892).

SCHMIDT, A.

Laws of combustion of solid explosives, especially powders, in the light of new kinetic reaction conceptions (with reference to the work of Muraour, H.). *Zeit. Sch. Spr.* pp. 1, 45, 82 (1932).

Laws of combustion of solid explosives. *Zeit. Sch. Spr.* 27 (1932).

(With Becker, F.). The heats of formation of nitrocellulose, nitroglycerine and other important components of propellants. *Zeit. Sch. Spr.* p. 280 (1933).

SCHUGT, J.

Methods for rapidly determining internal ballistic data for guns. L. F. A. Volkenrode : MOS Translation No. 137 : G.D.C. 2488T (1945).

SCHWEIKERT, G.

Innere Ballistik. Pub. in Leipzig (1923).

SEBERT, H.

Investigation of the effects produced by a propellant. *Mem. Art. de la Marine.* (1882).

SECONDO, B DI S.

The use of muzzle velocity measurements for the control of crushers, etc. *Riv. Art.* p. 459 (1929).

Vade-mecum of internal ballistics. Differential formulae. *Riv. Art.* p. 181 (1936).

SEIFERT, J.

A propellant of high force and low explosion temperature. *Voj. Tech. Zpr.* p. 217 (1935).

SHERMAN, J.

See Hirschfelder, J. O.

SMITH, D. W.

The methods in present use for charge estimates and ballistic design of guns. A.C. 1454/I.B. 44 (1941).

SMITH, N. M.

The piezo-electric projectile accelerometer and a bore-friction gauge. NDRC. A.59. OSRD. No. 808 (1942).

(With Crocker, J. A.). Measurement of various ballistic quantities on a projectile moving in the bore of a gun. NDRC. A.259. OSRD. No. 3376 (1944).

SOODAK, H.

See Nordheim, L. W.

SPALDING

Internal ballistics of small weapons. Rheinmetall-Borsig Rep. Unt. 204. A.R.D. Ballistic Branch Translation 10/46. (1946).

SPETZLER, C.

Short-start resistance in a gun and its mathematical treatment. *Mem. Art. Fr.*, pp. 869-920 (1938).

STOCKS, K. M.

See Jones, A. E.

SUGOT, G.

Cours de Balistique. Pub. in Paris. (1918).

Précis of internal ballistics. Mem. Art. Fr. p. 979 (1924).

Theoretical internal ballistics. Mem. Art. Fr. p. 1131 (1926).

Balistique intérieure théorique et tables numériques. Pub. in Paris (1928).

Theoretical study of the burning of progressive powders. Mem. Art. Fr. p. 821 (1933).

SZALBER, L.

The method of Le Duc. Minszaki Szembe, p. 212 (1928) ; p. 509 (1930).

THOMPSON, L.

(With Riffolt, N.). Ballistic engineering problems. Experimental development. U.S. Nav. Inst. 58 (1932).

See also Webster, A. O.

THORNHILL, C. K.

Some theoretical considerations of the problem of gun erosion. AC. 5570/Bal. 145 (1943).

Erosion of guns : heat transfer in lined gun barrels. A.R.D. Th. M. 5/44 (1944).

Notes on the continuous heating of a gun barrel during successive firings with revision of experimental results derived in A.R.D. Th., 29/44, A.R.D. Th. M., 3/45 (1945).

(With Ware, H. N., Griffiths, E. and Hickman, M. J.). The heating of a gun barrel by the propellant gases II. Comparison between theoretical and experimental values of heat transfer in small arms. A.C. 7091/Bal. 209 (1944).

See also Hicks, E. P.

THRING, L. G. P.

The Thring gauge for measuring high pressures. The Engineer (1928).

TIEMROTH

Method of calculating the constants of a powder. Dansk. Art. Tid. p. 133 (1922).

TRANter, C. J.

A system of internal ballistics. A.C. 1329/I.B. 32 (1941).

The effect of variations in the loading conditions in internal ballistics. Jour. Roy. Art. p. 254 (1945) and M.C.S. G.M. 8.

See also Hunt, F. R. W.

TSCHAPPAT, W. H.

Ordnance and gunnery. Pub. in U.S.A. (1917).

URRY, W. D.

(With P. J. Hannan). The state of equilibrium among the carbon atoms of a propellant gas. NDRC. A.303. OSRD. No. 4461. (1944).

U.S.A. DEPT. OF NAVY, BUREAU OF ORDNANCE (Staff of)
Practical interior ballistics. Pamphlet No. 411 (revised 1916).

VALLIER, E.

Empirical solution of the ballistic problem. Mem. Poud. p. 129 (1902).

Also C.R. 128, 129 (1899) ; 133 (1901) ; 135 (1902).

Balistique des nouvelles poudres. Pub. in Paris (1915).

VELA, M.

Calculation of the correction to muzzle velocity for the propellant temperature. *Rev. Gen. Mar.* p. 361 (1928).

VIEILLE, P.

Investigation on the mode of combustion of explosive substances. *Mem. Poud.* p. 256 (1893). Other papers include, *Mem. Poud.* III (1890); IV (1891); XI (1901-2).

See also Sarrau, E.

VINTI, J. P.

The effective velocity of escape of the powder gas from a gun. *B.R.L.* 538 (1945).

(With Chernich, J.). Interior ballistics of the post-combustion period. *B.R.L.* 600 (1946).

See also Kent, R. H.

VOITURIEZ, M.

The problem of internal ballistics and passive resistances. *Mem. Art. Fr.* p. 131 (1925).

Studies of internal ballistics. Piobert's coefficient. Kinetic energy of the charge. *Mem. Art. Fr.* p. 45 (1933).

WARE, H. N.

The influence of muzzle velocity on the efficiency of a recoilless gun. *A.C.* 8328/*Bal.* 279 (1944).

See also Corner, J. ; Thornhill, C. K.

WATSON, G. D.

(With Bate, M. and Dumas, R. L.). Extended Hunt-and-Hinds tables for internal ballistic computations. *I.B.R.L.* 16 (1944).

WEBSTER, A. O.

On the Springfield rifle and Le Duc's formula. *Proc. Nat. Acad.* p. 289 (1920).

Experimental results for interior ballistics. *Physics Review*, p. 378 (1923).

(With Thompson, L.). A new apparatus for measuring pressure in a gun. *Proc. Nat. Acad.* p. 259 (1919).

WEDEMEYER, E. M.

The maximum muzzle velocity. *Heerestechnik*, p. 180 (1928).

WENZEL, F.

(With Pachmann-Bogota, W.). An example of the influence of climate on the velocity of projectiles and gas pressure. *Zeit. Sch. Spr.* p. 12 (1928).

WINTER, R.

Theoretical internal ballistics. *Mem. Art. Fr.* p. 775 (1939).

WOMERSLEY, J. R.

Statistical analysis of measurements of muzzle velocity and maximum pressure at cordite proof and gun proof. *A.C.* 1337/*I.B.* 35 (1941).

WOOD, A. M.

See Crank, J.

WRIGHT, C. E.

See Hunt, F. R. W.

YAMAGA, N.

Calculation of the force and other important constants of explosives. *Jour. Eng. Tokio*, 17 (1927).

On the combustion velocity of smokeless powders. *Zeit. Sch. Spr.* p. 60 (1930).

AUTHOR INDEX

(The numbers refer to the pages. References are not given to entries in the bibliography pp. 291-306.)

- Abel, F., 2, 4
 Alger, P. R., 141, 142
 Amble, O., 127
- Balfour, C. M., iii, 169, 170
 Belajev, A. F., 26
 Berthelot, M., 2
 Blasius, H., 274
 Booth, F., 29
 Boulanger, Gen., 3
 Boulengé, P. le, 3, 148
 Bourne, W., 1
 Boys, S. F., 24, 25, 26, 35, 64
 Buri, A., 274
- Challeat, J., 141
 Charbonnier, P., 3, 65, 66, 102
 Clemmow, C. A., iii, 117
 Clemmow, D. M., 64, 272
 Collado, L., 1
 Cooke, C. J., 237
 Coppock, S. W., 111, 119
 Corner, J., iii, 11, 12, 13, 17, 18, 22, 24, 25, 26, 29,
 35, 38, 39, 75, 237, 242, 257
 Craig, R. A., 55
 Crank, J., 126
 Crawford, B. L., 26
 Crow, A. D., 20, 21, 24, 25, 55, 61, 108, 118, 169
 Curtis, H. L., 211
- Davies, O. L., 191
 Duncan, G. A., 55
 Durand, W. F., 274
- Eldred, Master-Gunner, 1
- Fishenden, M., 278
 Fisher, R. A., 234, 235, 236
 Flint, H. A., iii, 63
 Frank-Kamenetsky, D. A., 26
- Goldie, A. W., iii, 82, 94, 112
 Goldschmidt, H., 278
 Goldstein, S., 274
 Goode, J. B., iii, 75, 78, 208
 Goodspeed, F. M. C., 272
 Gossot, F., 3
 Green, H., 63
 Grimshaw, W. E., 20, 21, 24, 25, 55, 61, 169
- Hartree, D. R., 126
 Hepner, W. A., 80
 Hicks, E. P., iii, 76, 77, 273
 Hinds, G. H., iii, 25, 61, 82, 102, 242
 Hirschfelder, J. O., 19, 20, 21, 22, 224, 237
 Hugoniot, A., 260, 269
 Hunt, F. R. W., iii, 25, 61, 82, 102, 242
 Hutton, C., 1
 Hymans, J. C. S., iv, 203
- Ingalls, J. M., 3
- Jeffreys, H., 282
 Johnson, N. L., 205
 Joule, J. P., 2
- Kármán, Th. v., 276
 Kent, R. H., 80
- Lacey, L. J., 111
 Lagrange, J. L., 2, 74, 81
 Le Duc, A., 141
 Lenk, Baron von, 2
 Lennard-Jones, J. E., 39
 Létang, G., 24
 Liouville, R., 3
 Lockett, N., 75, 78, 208, 209
 Love, A. E. H., 71, 81
- McAdams, W. H., 278
 Michel, J. G. L., 127
 Moisson, A., 3
 Muraour, H., 23, 24, 25, 56
- Nicolson, M. M., 82
 Noble, A., 2, 3, 4
 Nye, Master-Gunner, 1
- Pack, D. C., 75, 242
 Partridge, E. P., 278
 Patterson, G. W., 141, 142, 143
 Pearson, E. S., 205
 Petavel, J. E., 169, 170
 Pidduck, F. B., 81, 108, 138
 Pike, H. H. M., iv, 9, 38, 62, 63, 278, 285
 Piobert, G., 2, 40, 102
- Rateau, A., 240, 263, 269
 Résal, H., 2, 67
 Riabouchinsky, D., 237
 Rice, O. K., 26
 Robins, B., 1
 Rodman, T. J., 2
 Rossmann, T., 209
 Rumford, B. T., 1
 Ruston, A. F., 111
- Sarrau, E., 3
 Saunders, O. A., 278
 Schack, A., 278
 Schmidt, A., 24
 Schönbein, C. F., 2
 Schultze, E., 2
 Schumacher, W., 24
 Schweikert, G., 24
 Sherman, J. H., 19, 224
 Siacci, F., 159
 Strecke, J., 237, 249
 Studler, R. R., 238
 Sugot, G., 3, 66, 72, 102, 103, 105, 108

Thomson, J. J., 164
 Thornhill, C. K., iv, 71, 76, 77, 273
 Thring, G. P., 169
 Tschappat, W. H., 49
 Tranter, C. J., iii, 82
 Trubridge, G. F. P., 272

Uffelmann, F. L., 155

Vickers, T., 253, 257
 Vieille, P., 3, 4
 Vinti, J. P., 237, 257

Walker, J. R. D., iv
 Ware, H. N., 257
 Whiston, J. R. H., iv
 Womersley, J. R., 190
 Wright, C. E., iv
 Wynn-Williams, C. E., 154

Yamaga, N., 24
 Yates, F., 234, 235, 236

Zeldowitch, J. B., 26

GENERAL INDEX

(The numbers refer to the pages)

- Absolute ballistics**, 176
Acceleration of projectile, experimental determination of, 210
Accuracy, of Boulengé chronograph, 150; of P.C.C. system, 157
Adiabatic flame temperature, 8, 13, 224
Adjusted charges, 179; errors arising out of, 204; for howitzers, 139
All-burnt, particular case for $\theta' = 0$, 87; tabular solution for, 94; values at by Hunt-Hinds solution, 86; values at for non-linear rate of burning, 120, 122, 124
American propellants, 5
Analysis of variance, 191, 197
Anti-interference round, 174
Approximate methods, of thermochemical calculation, 19
Approximations, 134-147 (Chapter XI); to form function for multitube, 50; in Sugot's solution, 106
Atomic composition, of propellant constituents, 8, 217; of propellants, 10, 218
A.R.D. Reports, iv
Armament Research Establishment, 148, 155, 172, 208
- Ballistic functions for NCT**, table for, 233
Ballistic similitudes, 143; compounded guns, 145; dynamical similarity, 146; geometrical similarity, 144; reduced dimensions, 146
Ballistics Committee, iii
Band engraving, losses due to, 72; method of allowing for, 115
Band pressure, 213
Blending of propellant, 173
Bomb calorimeter, 7, 16, 17
Bore resistance, methods of allowing for, 115
Boulengé chronograph, 3, 148; accuracy of, 150; disjunction of, 150
Breaks in ballistics, 180
Breech pressure, 75
Burning, theory of 23-39 (Chapter III); application of theory to cordite, 35; by parallel layers, 2, 40; laws of, 2, 40; rate of, 4, 37, 40, 55, 62, 115
Burning surface, variation of, 52
- Calorific value**, of propellants, 7, 17, 216
Cambridge Mathematical Laboratory, 128, 271, 284
Charbonnier's form function, 65, 103
Charge temperature, effect of variations on muzzle velocity, 134
Chronograph, Boulengé, 148; accuracy of, 150; disjunction of, 150
Chronometer, photoelectric counter, 148, 151, 154; accuracy of, 157; complete unit, 155; electric signal of, 153
Closed vessel, 2, 3, 7, 53-66 (Chapter V); description of, 160; experimental work in, 160; firing a round in, 162
Collected formulae, in Hunt-Hinds solution, 99
Combination of variations, at cordite proof, 203
Combustion, at constant volume, 53-66 (Chapter V); phenomena in closed vessel, 55
Comparative ballistics, 177
Composite charges, 135
Conditioning round, 174
Conduction of heat through barrel, 280; effect of discontinuity in boundary conditions, 282; empirical formulae for, 288; general remarks on, 280; heat loss to barrel, 283; numerical applications, 284; numerical calculation of temperatures, 283; solution of conduction equation, 280
Conservation of energy, 67
Control charts, 179, 182, 191, 200, 205
Conversion of observed to muzzle velocity, 159
Cordite, compressibility of, 37; thermal conductivity of, 36, 38
Correlation, of two or more variables, 191, 200
Co-volume of propellant gases, 3, 18, 22; correction for maximum pressure in Hunt-Hinds solution, 92; corrections for in classical theory of nozzles, 240; experimental determination of, 53
Crusher, gauge, 3, 163; pressures 98
Current standardisation, 177
Cylindrical propellants, form function for, 41
- Degrees of freedom**, (statistical), 192
Degressive shape, of propellant, 41

- Density of loading**, in closed vessel, 57; in gun, 214
- Differences in methods**, of solution of ballistic equations, 102
- Differential analyser**, use in solution for non-linear burning with simplified equations, 126; with general equations, 128
- Diffusion**, effect on rate of burning, 26, 38
- Disjunction time**, of Boulengé chronograph, 150
- Dissociation**, of products of explosion, 12, 14
- Driving-band pressure**, 213
- Electric signal**, of P.C.C., 153
- Empirical corrections**, for band engraving and bore resistance, 115; for variations in γ , 115; in Coppocks' solution, 112; in Crow's solution, 110; in general, 115; in Goldie's solution, 115
- Empirical formulae**, for heat loss to barrel, 288
- Energy equation**, 67-73 (Chapter VI)
- Energy**, kinetic of gases, 70, 79; kinetic of recoil, 71; losses in Hunt-Hinds solution, 96; lost in band-engraving and friction, 72; lost to gun, 71; released by propellant, 67; rotational, 72; secondary losses in gun, 70; strain, 71
- Equation**, of energy, 67-73 (Chapter VI); of motion, 74-81 (Chapter VII)
- Equation of state**, of propellant gases, 18; table of coefficients B and C, 221
- Equilibrium constants**, 11; table of, 219; table of coefficients ΔB and $\frac{1}{2}\Delta C$, 202
- Equivalent full charge (E.F.C.)**, 176
- Erosion**, of cordite, 38, 64; of gun, 4
- Experimental internal ballistics**, 208-213 (Chapter XVI); experiments in Germany, 209; in U.K., 208; in U.S.A., 211
- Experiments, in closed vessels**, 53; to determine force constant and co-volume, 53; to determine rate of burning, 58
- Explosion**, thermochemistry of, 8-22 (Chapter II); pressure of, 17; products of, 10; temperature of, 13, 19, 21
- F-test**, 193; table for, 235
- Fixed charge zone**, 205
- Flake**, form function for, 44
- Flame theory**, in gas, 26; table of functions for solution of equation, 225
- Flash**, 4, 5
- Force constant**, 17, 22; experimental determination of, 53
- Form coefficient**, 51, 65
- Form function**, 40-52 (Chapter IV); approximation for multitube, 50; Charbonnier's, 65; for cylindrical, 41; for French propellants, 66; for multitube, 44; for ribbon, 43; for slotted tube, 42; for square flake, 44; for tubular, 41
- Freezing temperature**, 17
- French propellants**, form function for, 66
- Friction pressure gradient**, 74, 76
- Frictional energy losses**, 72
- Gas composition**, change with temperature, 16; internal energy of, 13
- Gauge**, crusher, 163; piezo-electric, 164; spring, 168; strain, 168
- German propellants**, 6
- Gun-to-gun variations**, 175
- Heat loss**, effect on rate of burning, 60; in closed vessel, 54, 59; in gun, 71; calculation of, 283, measurement of, 212
- Heat of formation**, of products of explosion, 15, 218; of propellant constituents, 9, 217; of solid propellant, 10, 218
- Heating of barrel by gases**, 271-290 (Appendix II); assumptions in theory, 272; boundary-layer momentum integral, 275; boundary-layer thickness, 278; calculation of heat-transmission coefficient, 278; conduction of heat through barrel, 280; general remarks, 272; heat transmission coefficients, 276; state of gases, 272; velocity distribution across boundary-layer, 274
- Heats**, ratio of specific, 19
- High-low pressure gun**, 261; equations after all-burnt, 269; equations up to all-burnt, 264; summary of working formulae, 269
- Howitzers**, interpolation of adjusted charge weights for, 139
- Hunt-Hinds analysis of closed vessel records**, 61
- Hunt-Hinds system of internal ballistics**, 82-101 (Chapter VIII); after all-burnt, 87; all-burnt, 86; collected formulae, 99; co-volume correction for maximum pressure, 92; energy losses, 96; expressions for ξ and ζ , 85; initial conditions, 83; maximum pressure, 88; muzzle velocity when charge is not all burnt in bore, 95; particular case of $\theta' = 0$, 87, 90; practical applications, 97; pressure-space curve, 88, 95; reduction of equations, 82; solution of equations during burning, 83; solution when B is small, 89; tables of functions required in solution, 227-231; tabular solution, for all-burnt, 94; for maximum pressure, 90, for muzzle velocity, 93
- Hymans' effect**, 176, 203
- I.C.I. Ltd.**, 5
- Ignition**, 4, 40, 51, 81; in closed vessel, 59; temperature of, 40
- Inertia pressure gradient**, 74
- Initial conditions**, for gun equations, 83
- Interferometer**, use of, 211
- Internal energy**, of gases, 13; table of coefficients, E_1, E_2 , 223
- Interpolation of adjusted charge weights**, for howitzers, 139
- Kinetic energy**, of gases, 70, 79; of recoil, 71
- Krupps**, 144, 209
- Lagrange's ballistic problem**, 74
- Le Duc system of ballistics**, 141
- Leaking guns**, theory of, 237-270 (Appendix I); calculation of recoil momentum, 260; equations of internal ballistics, 242; equivalent non-leaking ballistic problem, 246; high-low pressure gun, 261; numerical integration of equations, 249; recoillessness, 259; solution after all-burnt, 254; solution with linear rate of burning, 250; smooth-bore mortar, 256; worn gun, 257
- Linear rate of burning**, solution of equations for, 82-101 (Chapter VIII); other solutions, 102-116 (Chapter IX)
- Loading density**, in closed vessel, 57; in gun, 214

- Maker-to-maker variations**, 175
- Master standardisation**, 176
- Maximum pressure**, approximate value by Hunt-Hinds solution, 88, 90, when $\theta'=0$, 89; by Coppock's solution, 111; by Crow's method, 109; by Goldie's solution 113; by Sugot's solution 105; condition for true, 91; co-volume correction for, 92; for non-linear burning and constant burning surface, 120; with simplified energy equation, 122, with general form function, 124; tabular solution, 90
- Mean deviation**, 201
- Mean gas pressure**, 75; and equation of motion, 79
- Military College of Science**, iv, 82
- Molecular heats**, table of, 220
- Monomial formulae**, for variations in loading conditions, 137
- Mortar**, gas leakage in, 256
- Motion**, equation of, 74-81 (Chapter VII)
- Multitubular propellants**, form function for, 44; erosion of, 64
- Muzzle velocity**, by Coppock's solution, 107; by Crow's method, 110; by Goldie's solution, 114; by Hunt-Hinds method, 88, 93; by Sugot's solution, 107; conversion from observed velocity, 159; for non-linear burning and constant burning surface, 121, with simplified energy equation, 122, with general form function, 124; tabular solution, 93; when charge is not all burnt in bore, 95
- Nobel and Abel's law**, 53
- Nomenclature of propellants**, 6
- Nominal charge weight**, 183
- Non-linear rate of burning**, solution for, 117-133 (Chapter X); for constant burning surface, 118, all-burnt, 120, maximum pressure, 120, velocity, 120, with simplified energy equation, 121; for general form function, 122; for general form function and simplified energy equation, 124; reduced equations, 117; solution by differential analyser, 126, 128
- Notation**, summary of, 214
- Nozzles**, classical theory of, 238; co-volume corrections, 240; thrust on, 241
- Numerical integration**, of ballistic equations for non-linear burning, 119; by differential analyser, 126; by step-by-step process, 123; of equations for leaking gun, 249
- Occasion-to-occasion variations**, 175
- Ounces and drams**, table of as decimals of a pound, 232
- Parallel layers**, burning by, 2, 40
- Photo-electric counter chronograph**, 148, 151; accuracy of, 157; complete unit, 155; electric signal of, 153
- Piezo-electric pressure gauge**, 164
- Population (statistical)**, 191
- Prandtl number**, 276
- Pressure**, breech, 75; crusher, 78, 98; driving band, 213; explosion, 17; index, 56; mean, 75, 79; measurements in closed vessel and gun, 160-171 (Chapter XIII); shot, 74, 210; shot-start, 3, 72, 83
- Pressure barrel**, 176
- Pressure gradient**, 69, 74, 76; experimental values of, 209, 210; frictional, 76; inertia, 74; total, 78
- Pressure-space curve**, in Hunt-Hinds solution, 88; when B is small, 95; when $\theta'=0$, 89
- Pressure-time curve**, in closed vessel, 57
- Progressive shape**, of propellant, 41
- Proof of propellants**, difficulty of, 174; methods of, 175; object of 173; of new nature, 183; special procedure, 183, specimen forms, 185
- Propellant proof**, 173-189 (Chapter XIV); difficulty of, 174; methods of, 175; object of, 173; of new nature, 183; special procedure, 183; specimen forms, 185
- Propellants**, 1-7 (Chapter I); American, 5; atomic composition of, 10, 218; atomic composition of constituents, 8, 217; calorific value of, 7, 17, 216; composition and physical properties of, 7, 216; co-volume of, 18, 22, 53, 224; double base, 4, 5; early developments of, 1; effect of co-volume on rate of burning, 38; effect of moisture and solvent content, 22; equation of state, 18; flashless, 4; force constant of, 17, 53; German, 6; heats of formation of, 10, 218; heats of formation of constituents, 9, 217; later developments of, 2; modern developments of, 4; nomenclature, 6; quickness of, 65; ratio of specific heats of, 19, 21; requirements of modern, 3; single base, 4, 5; stabilisers for, 4; stability of, 4; tables, 216, 224, 226, 231; thermochemistry of, 8-22 (Chapter II); types in use, 5; vivacity of, 65
- Propellants, theory of burning of**, 23-39 (Chapter III); applications to burning of cordite, 35; surface theories, 24; vapour-phase theories, 25
- Quality control**, 191
- Quickness**, of propellants, 65
- Range-table muzzle velocity**, 183
- Rate of burning**, of propellants, 4, 55; coefficient, 56; comparison between experimental and theoretical, 37; experimental determination of constants, 58; index, 56; method of allowing for non-linearity, 115; numerical values for constants, 62; table of indices and coefficients, 226
- Rate of pressure variation**, recording of, 172
- Reaction zone**, propagation of 27; approximate solution in special case, 30; equations for, 29
- Recoil measurements**, 212
- Recoil momentum**, in recoilless gun, 260
- Recoilless gun**, 259
- Reduction of ballistic equations**, 82; for non-linear rate of burning, 117
- Regression analysis**, 191, 195
- Résal's equation**, development of, 69; modified form of, 72
- Resistance of bore**, equations for numerical solution, 132; experimental values of, 209, 210, 213; method of allowing for, 115
- Reynold's number**, of gas flow in gun, 272
- Rheinmetall Borsig**, 146
- Ribbon**, form function for, 43
- Runge's numerical solution**, of ballistic equations, 119

- Sample**, (statistical), 191 ; mean, 192
Scientific Advisory Council, iii, 90
Secondary energy losses, in guns, 70
Shot-start pressure, 3, 72, 83
Significance, of differences, 190 ; tests, 193, 234, 235
Similitudes, ballistic, 143 ; compounded guns, 145 ; dynamic similarity, 144 ; geometric similarity, 144 ; reduced dimensions, 146
Size, of propellant, 40, 51
Slivers, 44
Slotted tube, form function for, 42
Solution of ballistic equations, for linear rate of burning ; 82-101 (Chapter VIII) ; during burning, 83 ; particular case of $\theta' = 0$, 90 ; when B is small, 89 ; by Coppock, 111 ; by Crow, 108 ; by Goldie, 112 ; by Le Duc, 141 ; by Sugot, 103 ; for non-linear rate of burning, 117-133 (Chapter X) ; with constant burning surface, 118 ; with differential analyser, 126, 128 ; with general form function, 122
Solvent content, of propellants, effect on force constant, 22 ; effect on rate of burning, 63
Space-time curve, experimental determination of, 211
Specific heats, ratio of for propellant gases, 19, 21
Specification charge weights, 183
Spring gauge, 168
Square flake, form function for, 44
Standard charge zone, 205
Standard deviation, 192
Standard gun, 175
State, equation of, 18
Statistical methods, applications to internal ballistics, 190-207 (Chapter XV) ; applications to routine problems, 204, 207 ; types of problem which can be solved, 190
Statistical terms, definitions, of, 191
Step-by-step integration, of ballistic equations, 132
Storage temperature, 4 ; effect on rate of burning and force constant, 63
Strain energy, of gun, 71
Strain-gauge pressure head, 168
Sugot's method, of solution of ballistic equations, 103 ; functions, 107
Summary of notation, 214
Surface temperature, of barrel, 289
- T-test**, 194 ; table for, 234
Tables, 215-236 ; additive constants of propellant constituents, 224 ; atomic compositions and heats of formation of propellant constituents, 217 ; atomic compositions and heats of formation of propellants, 218 ; ballistic functions for NCT, 233 ; compositions and physical properties of propellants, 216 ; equation of state coefficients B and C, 221 ; equilibrium constants, 219, 222 ; functions for Hunt-Hinds solution, 227-231 ; functions for solution of flame equation, 225 ; heats of formation of products of explosion, 218 ; internal energy coefficients E_1 , E_2 , 223 ; mean molecular heats, 220 ; ounces and drams as decimals of a pound, 232 ; propellant constants, 224 ; propellant data in British units, 231 ; rate of burning indices and coefficients, 226 ; significance test, 234 ; summary, 215 ; variance tests, 235
Tabular solution, for Goldie's solution, 114 ; for Hunt-Hinds solution, 90, 93, 94 ; for Sugot's solution, 107
Taylor Model Basin, 211
Temperature, adiabatic flame, 8, 13 ; at barrel surface, 289 ; freezing, 17 ; in barrel wall, 283, 289 ; in closed vessel, 59 ; in gun, 211 ; of explosion, 13 ; of ignition, 40 ; of storage, 4, 63 ; touch-off, 25
Tests of significance, 193
Thermal conductivity, of cordite, 36 ; effect on rate of burning, 38
Thermochemistry, of propellant explosions, 8-22 (Chapter II)
Thrust, on nozzle, 241
Time of burning, in closed vessel, 57
Tolerance, in proof shot weight, 203
Tubular propellants, erosion of, 64 ; form function for, 41 ; irregularity of, 51
- Units**, in Hunt-Hinds solution, 97
- Vapour-phase**, theories of burning, 25
Variance, 192
Variations, in charge temperature, 134 ; in effective chamber capacity, 203 ; in initial conditions by Sugot's method, 108 ; in muzzle velocity measurements, 202 ; in propellant web size, 203 ; in γ , 115 ; monomial formulae for, 137 ; nature of ballistic, 174 ; of muzzle velocity at ballistic firings, 201
Velocity measurement, 148-159 (Chapter XII)
Velocity of adjustment, 177, 179
Vickers-Armstrongs, Ltd., iii, iv, v, 138
Vivacity, of propellant, 65
- Warmer round**, 174
Water content, of propellant, effect on force constant, 22 ; effect on rate of burning, 63
Water-gas reaction, 11
Waves, pressure, 80
Weapon Research Committee, iii
Wear curves, 182
Web, for multitubular propellants, 44
Work, done in expansion in gun, 68
Worn gun, ballistics of, 257

ANOTHER RARE BOOK BROUGHT
TO YOU BY
THE DARKWIZARD.